

# **Doheny's**

**Pool Supplies FAST!**

# **2-Speed Pumps**

**Item #s 7813, 7814, 7818 & 7819**

## **INSTALLATION, OPERATION & PARTS**



**In-ground 2-Speed Pumps  
Item #s 7818 & 7819**



**Above Ground 2-Speed Pumps  
Item #s 7813 & 7814**



To prevent potential injury and to avoid unnecessary service calls, read this manual carefully and completely.

**SAVE THIS INSTRUCTION MANUAL** Use of appointed replacement parts voids warranty.

**ATTENTION INSTALLER – THIS MANUAL CONTAINS IMPORTANT INFORMATION ABOUT THE INSTALLATION, OPERATION, AND SAFE USE OF THIS PUMP THAT MUST BE PROVIDED TO THE END USER OF THIS PRODUCT. FAILURE TO READ AND FOLLOW ALL INSTRUCTIONS COULD RESULT IN SERIOUS INJURY.** This equipment must be installed and serviced by a qualified technician. Improper installation can create electrical hazards which could result in property damage, serious injury or death. Improper installation will void the warranty.

## Symbol means:

### ▲ DANGER

Indicates that if failure to avoid potential hazard, **will** cause severe personal injury or death or property damage.

### ▲ WARNING

Indicates that failure to avoid potential hazard, **could** result in severe personal injury or death or property damage.

### ▲ CAUTION

Indicates that failure to avoid potential hazard, **will or could** cause moderate personal injury or property damage.

## INSPECTION

Examine the equipment when received. Notify your dealer or carrier of any damage or missing parts. Verify that equipment is of size and model specified.

## CHAPTER 1:

### IMPORTANT SAFETY INSTRUCTIONS

When installing and using this electrical equipment, basic safety precautions should always be followed, including the following:

## READ AND FOLLOW ALL INSTRUCTIONS

### ▲ WARNING Pay Attention to Children.

1. To reduce risk of injury, do not permit children to use or climb on this product. Closely supervise children at all times. Components such as the filtration system, pumps, and heaters must be positioned to prevent children from using them as a means of access to the pool.

### ▲ WARNING For cord & plug connected units

2. Risk of Electrical Shock. Connect only to a grounding type receptacle protected by a ground-fault circuit-interrupter (GFCI). Contact a qualified electrician if you cannot verify that the receptacle is protected by a GFCI.

### ▲ WARNING For cord & plug connected units

3. Do not bury cord. Locate cord to minimize abuse from lawn mowers, hedge trimmers and other equipment.

### ▲ WARNING For cord & plug connected units

4. To reduce the risk of electric shock, replace damaged cord immediately.

### ▲ WARNING For cord & plug connected units

5. To reduce the risk of electrical shock do not use an extension cord to connect unit to electrical supply; provide a properly located outlet.

### ▲ CAUTION For pumps with/without 3-ft (91m) cord or 6-ft (1.82m) cord

6. This pump is for use with permanently installed pools and may also be used with hot tubs and spas if so marked. Do not use with storable pools. A permanently installed pool is constructed in or on the ground or in a building such that it cannot be readily disassembled for storage. A storable pool is constructed so that it may be readily disassembled for storage and reassembled to its original integrity.

### ▲ WARNING For hot tub and spa pumps

7. Do not install within an outer enclosure or beneath the skirt of the hot tub or spa, unless so marked.
8. **SAVE THESE INSTRUCTIONS.**

## CHAPTER 2: INSTALLATION LOCATION

Locate pump as close to pool/spa as possible, preferably in a dry, well ventilated area away from direct sunlight. It should be on a hard, level surface. Give consideration to:

1. Drainage – away from pump.
2. Ventilation of pump motor.
3. Access for future servicing and winterizing.
4. Protection from the elements.

Pumps without strainer bodies are designed for flooded suction (all suction fittings and suction piping below water level) and will not self-prime. Consequently, the pump must be installed at an elevation that is below water level when pool or spa is filled; however, if suction line valves are installed, the pump may be closed for priming. Keep vertical distance to a minimum if you choose to mount pump above water level. Pumps with strainer bodies are self-priming but should be mounted as close to the water level as possible or below for ease in priming.

## CHAPTER 3: GENERAL PLUMBING

### For Solvent Weld Connection

Rigid or flexible PVC pipe can be used. Pipe ends should be clean and free of any flash caused by the cutting operation. Be sure that the proper adhesive is used on the type of pipe specified. **Note:** A primer will assure that adhesive joints are superior. Suregard P-3000 has a purple tracer to qualify in areas where codes specify a primer must be used. **Caution:** We recommend that you consider climatic conditions when applying adhesives. Certain atmospheric situations, such as high moisture content, make adhesive action of certain glues less effective. Check the manufacturer's instructions.

## For Threaded Connections

Use only Teflon tape or equivalent on threaded plumbing connections. Other pipe compounds may damage threads. We do not recommend the use of silicone or petroleum based compounds. DO NOT OVERTIGHTEN – HAND TIGHTEN PLUS ½ TURN IS SUFFICIENT.

## CHAPTER 4: PUMP PLUMBING

Suction pipe should be as large or larger than discharge pipe. Avoid using suction pipe smaller than pump connection. Keep the piping as straight and short as possible, and of suitable size. Avoid connecting an elbow directly into the pump inlet (use a length of straight pipe to allow a proper entry for the water). Arrange horizontal runs to slope upward to the pump to prevent high spots that could form air pockets. Support the pipe independently so that it places no strain on the pump. Keep as much of the suction line as possible below the water level to reduce priming time. Install valves and unions in the pump suction and return lines to facilitate servicing. Valves are recommended for throttling maintenance if the system is installed below deck level. Suction valves are essential for priming all pumps without strainer bodies installed above water level. Pumps with strainer bodies are self-priming, nevertheless, we recommend the use of check valve in the suction pipe at or below the water level if the suction lift is more than five feet or if the dry suction is more than ten feet long. Keep the valve in the suction line fully open during operation.

## CHAPTER 5: ELECTRICAL DATA

Refer to information on motor nameplate for electrical service data. All motors should have fused disconnect switch or circuit breaker. Be sure wire size is sufficient for pump HP and distance from power source. Wiring should be done in accordance with applicable codes by a competent electrician. We recommend the installation of a ground fault circuit interrupter for maximum safety.

## CHAPTER 6: PUMP START UP

### Gravity Fed Above Ground Pumps

Do not operate pump until it has been primed as water acts to cool and lubricate the seal. For pumps without strainer bodies and located above water, close suction line valve and fill pump with water in order to prime.

## Self Priming Inground Pumps

For pumps with strainer bodies and located above water, prime by removing strainer cover and filling strainer body with water. Pumps located below water level will selfprime if all piping is also below water level. After pump has been primed, energize motor and open all suction and discharge line valves. It may take some time for pump to remove air from suction lines. If no flow is observed in five minutes, stop the motor and re-prime. If the pump fails to operate, check for air leaks. Refer to Trouble Shooting section. After about ten minutes of operation, check the return fittings for air bubbles. A continuous flow of air indicates leaks in suction line. Locate and correct any leaks immediately.

## Controlling the Output

Keep the gate valve in the suction line fully open during operation. Should it be necessary to control the output, use a valve in the return line.

**Caution:** Do not retighten strainer Ring-Lok during operation.

**Caution:** Do not operate pump with closed suction or discharge valves.

## OPERATOR CONTROL PANEL

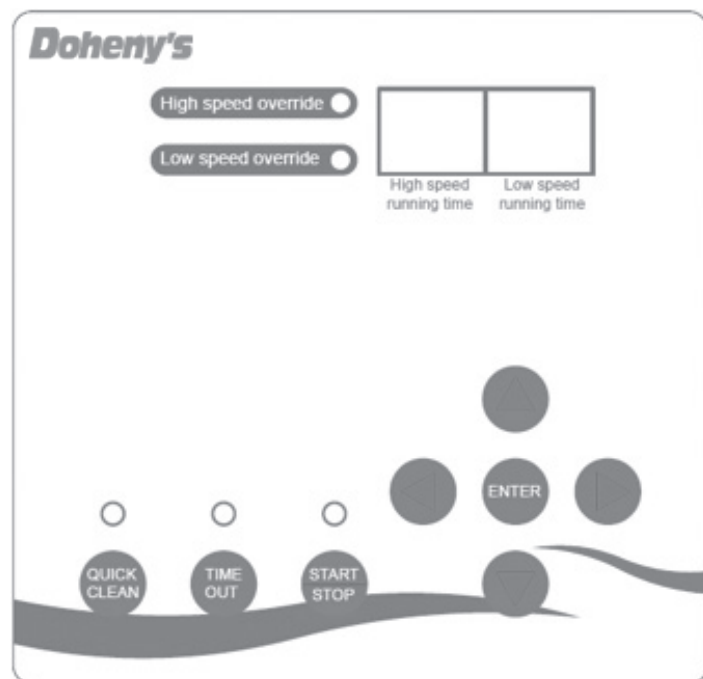

### I Push-Button and Function

1. **ENTER** (set up/confirm key), click to enter install status – set up –click to save;
2. **UP AND DOWN ARROW KEYS** are for time adjustment/ and location movement;
3. **LEFT AND RIGHT ARROW KEYS** are for cursor moving, current location will be flashing;
4. **QUICK CLEAN** when motor is under **START** status, click to run in high-speed for 3 hours; the same key to stop function.

5. **TIME OUT** is for pause (light on); the same key to wake up;
6. **START/STOP** is for start/stop.

## II Indicator Light

1. **HIGH SPEED OVERRIDE** starting with high-speed program; after finished high-speed programming time, automatically change to low-speed program;
2. **LOW SPEED OVERRIDE** starting with high-speed for 5 minutes (to exhaust air), changing to low-speed program; then running in high-speed program;
3. **QUICK CLEAN** is fast set for running in high-speed 3 hours; the same key to stop function;
4. **TIME OUT** is for pause; the same key to wake up.
5. **START /STOP** is for start/stop, light on means start.
6. **HIGH SPEED RUNNING TIME** time install for running in high speed(by hour);
7. **LOW SPEED RUNNING TIME** time install for running in low speed(by hour);  
**Notice: sum of high-speed running hours and low-speed running hours should not exceed 24 hours (24 hours is ok).**
8. **NIXIE TUBE** flash in high speed means pump is running in high speed, flash in low speed means pump is running in low speed, not flashing means idle condition.

## III Additional Illustration

1. Starting with low speed, motor will run on high speed for around 5 minutes.
2. Motor can be woken up from a screen saver model (nixie tube rolling) with any button;
3. Under STOP status, motor will enter a screen saver model (all switches turn off) after 30 seconds; can be woken up with any button;
4. In case of starting with Quick Clean or Time out (press bottom until light on), pump is going to performance with Quick Clean function or Time out function in certain period time; end function with the same key (press bottom until light off).

## CHAPTER 7: WINTERIZING

Consult your dealer for advice on winterizing your equipment if freezing temperatures occur in your locality. Their knowledge of your equipment makes them the best qualified source of information. Follow their recommendations, and if these include draining the filter system, proceed as follows:

1. If your system does not contain a filter, proceed to step 2.

- A. For sand filters: **BACKWASH** for 3 to 5 minutes and set dial valve to **WINTERIZE**.
- B. For cartridge filters: Clean the filter element and store in a dry place.

2. Drain system by loosening drain plugs (drain plugs will drain without completely removing the plug from unit) and/or removing pipe caps.

## CHAPTER 8: WATER CHEMISTRY

A proper and consistent use of chemicals is necessary to maintain clean, sanitary water, prevent a spread of germ infection and control the growth of algae which can spoil the appearance and enjoyment of your pool or spa. Chlorine is the most commonly used chemical to provide clean, sanitary water. Either dry or liquid chlorine (calcium or sodium hypochlorite) can be used which should be added daily as it is dissipated by dirt and germs as well as be the sun and wind. It is also important that the correct level of acidity or alkalinity of the pool water be maintained. This is the pH of your pool with pH 7.0 being neutral. Readings above 7.0 are alkaline and below are acid. A desirable range is 7.2 – 7.4.

## CHAPTER 9: PUMP MAINTENANCE

1. Motors are self-lubricating – no lubrication is required.
2. Clean hair & lint strainer if you have a strainer body pump.
3. Visually inspect motor for blockage of air vents on motor shell. Remove any debris after breaker off.
4. Shaft seals may become worn and must be replaced if leakage is observed.

## CHAPTER 10: CLEANING

Switch power off. Close valves in suction and return line. Unscrew strainer Ring-Lok counterclockwise and remove the strainer cover from hair and lint strainer and lift out strainer basket. Clean and replace the basket. Take care to seat basket properly. Clean O-Ring and re-lubricate with a non-pretroleum based lube, try Jack's Magic Lube. Clean O-Ring seats on cover and strainer. Refit cover and strainer – hand tighten only – and open valves. Put pump back into operation. **Caution: Do not retighten strainer during operation.**

## CHAPTER 11: SERVICE & REPAIR PARTS

Order all repair parts through your dealer. Give the following information when ordering repair parts:

1. Unit nameplate data.
2. Description of part



## CHAPTER 12: TROUBLESHOOTING

### Motor Does Not Start

1. Disconnect switch or circuit breaker in OFF position.
2. Fuses blown or thermal overload open. Locked motor shaft.
3. Motor windings burned out.
4. Defective starting switch inside single-phase motor
5. Disconnected or defective wiring
6. Low voltage

### Motor Does Not Reach Full Speed

1. Low voltage
2. 2-speed model set on low speed
3. Motor windings connected for wrong voltage on dual voltage model.

### Motor Overheats (Protect trips)

1. Low voltage
2. Motor windings connected for wrong voltage on dual voltage model.
3. Inadequate ventilation

### Pump Delivers No Water

1. Pump is not primed
2. Closed valve in suction or discharge line
3. Leakage or air into suction system
4. Impeller clogged

### Low Pump Capacity

1. Valve in suction or discharge line partly closed
2. Suction or discharge line partly plugged
3. Suction or discharge line too small
4. Pump running at reduced speed (see above)
5. Plugged basket in skimmer or hair and lint strainer
6. Dirty filter
7. Impeller clogged
8. Wrong rotation (3 phase only)

### Low Pump Pressure

1. Pump running at reduced speed (see above)
2. Wrong rotation (3 phase only)
3. Discharge valve or inlet fittings closed too much

### High Pump Pressure

1. Discharge valve or inlet fittings closed too much
2. Return lines too small
3. Dirty filters

### Noisy Pump and Motor

1. Plugged basket in skimmer or hair in lint strainer
2. Worn motor bearings
3. Valve in suction line partly closed
4. Suction line partly plugged
5. Vacuum hose plugged or too small
6. Pump not supported properly

### Leakage of Water at Shaft

1. Shaft seal requires replacement

### Air Bubbles at Inlet Fittings

1. Leakage air into suction line at connections or valve stem
2. Cover gasket of hair and lint strainer needs cleaning
3. Restriction in suction line
4. Low water level in pool

**NOTE: If the recommendations in the Troubleshooting portion of this manual do not solve your particular problem(s), please contact Doheny's.**

## CHAPTER 13: TECHNICAL DATA

ITEM#	HP	VOLT / HZ	AMPS	RPM
7813	1	115V / 60HZ	10A / 3.2A	3450 / 1720
7814	1.5	115V / 60HZ	12A / 3.6A	3450 / 1720
7818	1	115V / 60HZ	12A / 3.6A	3450 / 1720
7819	1.5	230V / 60HZ	7.5A / 2.1A	3450 / 1720

## Above Ground 2-Speed Pumps Item #'s 7813 & 7814

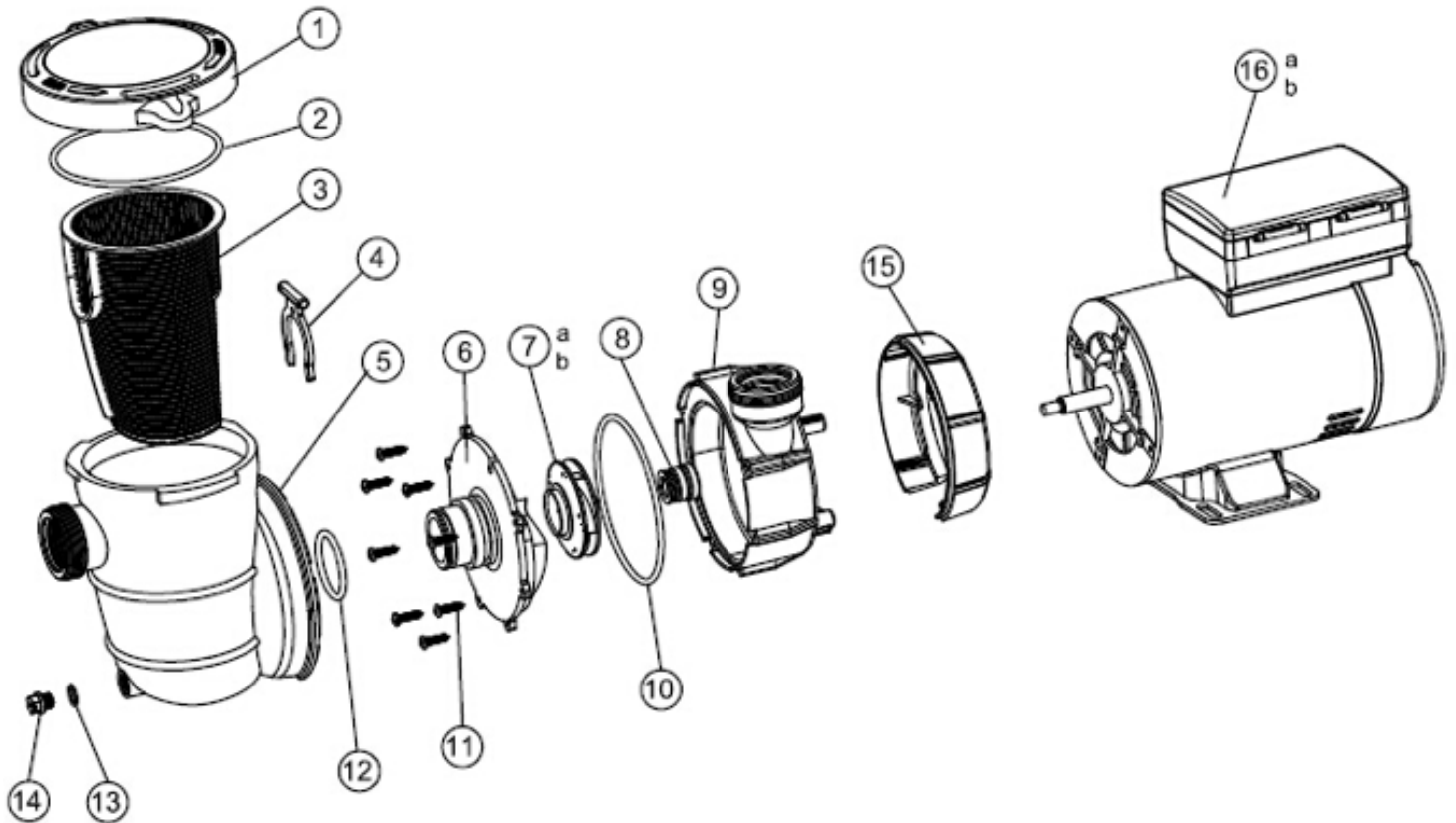

REF No.	PART NUMBER	DESCRIPTION	No. REQ'D
1	647252772000	Cover	1
2	65431042080	O-Ring	1
3	647252704001	Basket	1
4	647252705080	Clip	1
5	647252703080	Strainer Housing	1
6	647252702080	Pump Cover	1
7a	647272971000	Impeller for 7813	1
7b	647252771000	Impeller for 7814	1
8	65028003000	Seal Assembly	1
9	647252701080	Pump Housing	1
10	65431040080	O-Ring	1
11	65212016000	Screw ST5.5X25	8
12	65431029080	O-Ring	1
13	65432002080	Gasket	1
14	648860105080	Drain Plug	1
15	647252708080	Motor Mounting Plate	1
16a	65023173000	1.0 HP Two-Speed Motor for 7813	1
16b	65023174000	1.5 HP Two-Speed Motor for 7814	1

## In-ground 2-Speed Pumps Item #'s 7818 & 7819

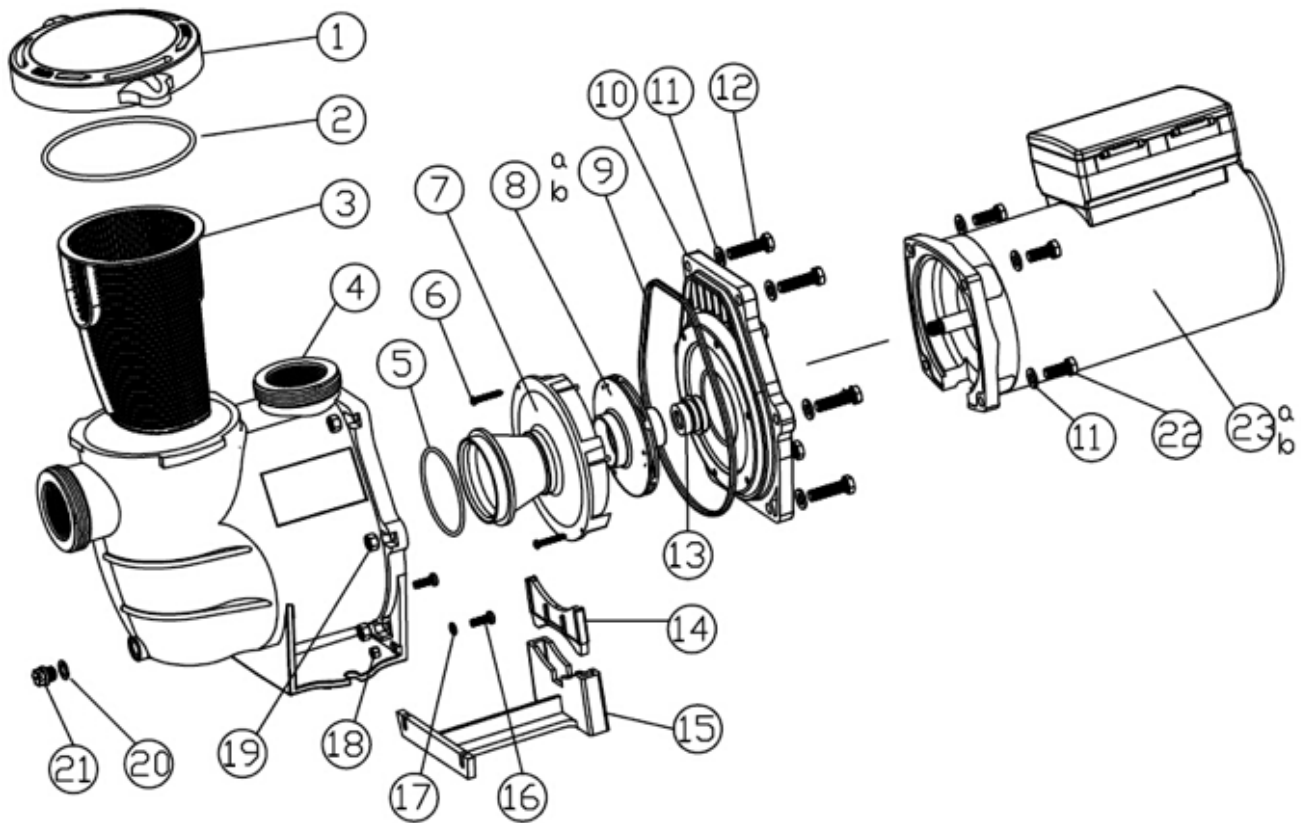

REF No.	PART NUMBER	DESCRIPTION	No. REQ'D
1	647252772000	Cover	1
2	65431042080	O-Ring	1
3	647252704001	Basket	1
4	647254701080	Pump Housing	1
5	65431032080	O-Ring	1
6	65212025000	Screw ST4.2X38	2
7	647254703080	Diffuser	1
8a	647274771000	Impeller for 7818	1
8b	647274871000	Impeller for 7819	1
9	65431074080	O-Ring	1
10	647254702080	Pump Cover	1
11	65244015000	Gasket M10	10
12	65225003000	Screw 3/8-16*1 1/2 UNC	6
13	65028014000	Seal Assembly	1
14	647254705080	Foot Insert	1
15	647254704080	Mounting Foot	1
16	65224003000	Screw M6X20	2
17	65244016000	Gasket M6	2
18	65231002106	Nut M6	2
19	65232001106	Nut 3/8-16	6
20	65432002080	Gasket	1
21	648860105080	Drain Plug	1
22	65244015000	Gasket M10	4
23a	65023186000	1.0 HP Two-Speed Motor for 7818	1
23b	65023189000	1.5 HP Two-Speed Motor for 7819	1

# 1 Year Limited Doheny's Pool Pump Warranty

Please read installation instructions before installing pool pump

This pump was inspected before shipment from our warehouse. To original purchasers of this pump, Doheny Enterprises, Inc., 6950 51st Street, Kenosha, Wisconsin, warrants its products free from defects in materials and workmanship for a period of **ONE** (1) year from the date of purchase.

Parts which fail or become defective during the warranty period, except as a result of freezing, negligence, improper installation, use, or care, shall be replaced, at our option, without charge, within 90 days of the receipt of defective product, barring unforeseen delays.

After 90 days, to obtain warranty replacements, defective components should be returned, transportation paid, to the place of purchase. For further Doheny's service, contact Doheny's customer care department. No returns may be made directly to the factory without the express written authorization of Doheny Enterprises, Inc.

To original purchasers of this pump, Doheny Enterprises, Inc. warrants its pump housing/strainer to be free from defects in materials and workmanship for a period of **ONE** (1) year from the date of purchase.

Strainers which become defective during the warranty period, except as a result of freezing, negligence, improper installation, use or care, or as the result of a use in association with an automatic valving system.

All other conditions and terms of the standard warranty apply.

Doheny shall not be responsible for cartage, removal and/or reinstallation labor or any other such costs incurred in obtaining warranty replacements.

The Doheny Enterprises, Inc. warranty does not apply to components manufactured by others. For such products, the warranty established by the respective manufacturer will apply.

Some states do not allow a limitation on how long an implied warranty lasts, or the exclusion or limitation of incidental or consequential damages, so the above limitation or exclusion may not apply to you.

This warranty gives you specific legal rights, and you may also have other rights, which vary from state to state.

## General Maintenance

1. Clean strainer basket regularly. Do NOT strike basket to clean. Inspect strainer cover gasket regularly and replace as necessary.
2. Pumps have self-lubricating motor bearings and shaft seals. No lubrication is necessary.
3. Keep motor clean. Ensure air vents are free from obstruction to avoid damage. Do NOT use water to hose off motor.
4. Occasionally, shaft seals must be replaced, due to wear or damage.

## Storage/Winterization

1. Do not purge the system with compressed air. Use only a low pressure (below 5 psi), high volume blower when air purging the pump, filter or piping.
2. Allowing the pump to freeze will void the warranty.
3. Use ONLY propylene glycol as antifreeze in your pool/spa system.
4. Drain all water from pump and piping when expecting freezing temperatures or when storing pump for a long time.
5. Keep motor dry and covered during storage. To avoid condensation/corrosion problems, do NOT cover or wrap pump with plastic film or bags.