

HAYWARD® Pool Products

One source. Every pool.



**Models: HP20654T, HP20654BT, HP20854T,
HP20854BT and HP21104T**

INSTALLATION GUIDE



Important Information to keep for Service

Model # _____

Serial # _____

Install Date _____

SAVE THIS INSTALLATION GUIDE

The Hayward HeatPro Heat Pump is listed by ETL as complying with the latest edition of the “UL Standard for Safety for Heating and Cooling Equipment”, UL1995 and CSA C22.2 No. 236.

All Hayward HeatPro Heat Pumps must be installed in accordance with all applicable National and Local codes. In the absence of local codes, refer to the latest edition of the National Electric Code (NEC) in the United States and the Canadian Electric Code (CEC) in Canada

Basic safety precautions should always be followed, including the following: Failure to follow instructions can cause severe injury and/or death.

▲This is the safety-alert symbol. When you see this symbol on your equipment or in this manual, look for one of the following signal words and be alert to the potential for personal injury.

▲WARNING warns about hazards that **could** cause serious personal injury, death or major property damage and if ignored presents a potential hazard.

▲CAUTION warns about hazards that **will** or **can** cause minor or moderate personal injury and/or property damage and if ignored presents a potential hazard. It can also make consumers aware of actions that are unpredictable and unsafe.

The **NOTICE** label indicates special instructions that are important but not related to hazards.

USE ONLY HAYWARD GENUINE REPLACEMENT PARTS

IMPORTANT SAFETY INSTRUCTIONS



READ AND FOLLOW ALL INSTRUCTIONS IN THIS INSTALLATION GUIDE AND ON EQUIPMENT.

Before installing or servicing this electrical equipment, turn power supply OFF.

KEEP ALL LABELS IN GOOD CONDITION AND REPLACE IF MISSING OR DAMAGED.

⚠ WARNING – To reduce risk of injury, do not permit children to use or climb on the heat pump, pumps or filters. Closely supervise children at all times. Components such as the filtration system, pumps, and heaters must be positioned to prevent children from using them as a means of access to the pool.

⚠ CAUTION – This heat pump is intended for use on permanently installed swimming pools and may also be used with spas. Do NOT use with storable pools. A permanently installed pool is constructed in or on the ground or in a building such that it cannot be readily disassembled for storage. A storable pool is constructed so that it is capable of being readily disassembled for storage and reassembled to its original integrity.

Though this product is designed for outdoor use, it is strongly recommended to protect the electrical components from the weather. Select a well-drained area, one that will not flood when it rains. It requires free circulation of air for cooling. Do not install in a damp or non-ventilated location.



⚠ WARNING –Risk of Electric Shock. All electrical wiring MUST be in conformance with all applicable local codes, regulations and the National Electric Code (NEC). Hazardous voltage can shock, burn, cause death or serious property damage. Provide a properly located outlet. All electrical wiring MUST be in conformance with applicable local and national codes and regulations. Before working on this unit, turn off power supply to the heat pump.

⚠ WARNING – To reduce the risk of electric shock replace damaged wiring immediately. Locate conduit to prevent abuse from lawn mowers, hedge trimmers and other equipment.

⚠ WARNING – Failure to bond heat pump to pool structure will increase risk for electrocution and could result in injury or death. To reduce the risk of electric shock, the electrician must comply with installation instructions and must bond the heat pump accordingly. In addition, the licensed electrician must also conform to local electrical codes for bonding requirements.

Notes to the electrician:

Use a solid copper conductor, size 8 or larger. Run a continuous wire from external bonding lug to reinforcing rod or mesh. Connect a No. 8 AWG (8.4 mm²) solid copper bonding wire to the grounding lug provided on the heat pump and to all metal parts of swimming pool or spa, and to all electrical equipment, metal piping (except gas piping), and conduit within 5 ft. (1.5 m) of inside walls of swimming pool or spa. **IMPORTANT** - Reference NEC codes for all wiring standards including, but not limited to, grounding, bonding and other general wiring procedures.



⚠ WARNING – Suction Entrapment Hazard.

Suction in suction outlets and/or suction outlet covers which are damaged, broken, cracked, missing, or unsecured can cause severe injury and/or death due to the following entrapment hazards:

Hair Entrapment- Hair can become entangled in suction outlets.

Limb Entrapment- A limb inserted into an opening of a suction outlet or suction outlet cover that is damaged, broken, cracked, missing, or not securely attached can result in a mechanical bind or swelling of the limb.

Body Suction Entrapment- A differential pressure applied to a large portion of the body or limbs can result in an entrapment.

Evisceration/ Disembowelment - A vacuum applied directly to the intestines through an unprotected suction outlet sump or suction outlet cover which is damaged, broken, cracked, missing, or unsecured can result in evisceration (disembowelment).

Mechanical Entrapment- There is potential for jewelry, swimsuit, hair decorations, finger, toe or knuckle to be caught in an opening of a suction outlet or suction outlet cover resulting in mechanical entrapment.

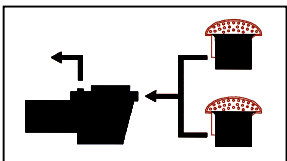

⚠ WARNING - To reduce the risk of entrapment hazards:

- o When suction outlets are less than a 18" x 23" [45cm x 58cm] equivalent, a minimum of two functioning suction outlets per pump must be installed. Suction outlets in the same plane (i.e. floor or wall), must be installed a minimum of three feet (3') [1 m] apart, as measured from near point to near point.
- o Dual suction outlets shall be placed in such locations and distances to avoid "dual blockage" by a user.

USE ONLY HAYWARD GENUINE REPLACEMENT PARTS

- Dual suction fittings shall not be located on seating areas or on the backrest for such seating areas.
- The maximum system flow rate shall not exceed the flow rating of any listed (per current revision of ASME/ANSI A112.19.8) suction outlet cover installed.
- Never use the Pool or Spa if any suction outlet component is damaged, broken, cracked, missing, or not securely attached.
- Replace damaged, broken, cracked, missing, or not securely attached suction outlet components immediately.
- In addition two or more suction outlets per pump installed in accordance with latest APSP (formerly NSPI) Standards and CPSC guidelines, follow all National, State, and Local codes applicable.

⚠ WARNING – Never operate or test the circulation system at more than 50 PSI.

⚠ WARNING – Failure to remove pressure test plugs and/or plugs used in winterization of the pool/spa from the suction outlets can result in an increase potential for suction entrapment as described above.

⚠ WARNING – Failure to keep suction outlet components clear of debris, such as leaves, dirt, hair, paper and other material can result in an increase potential for suction entrapment as described above.

⚠ WARNING – Suction outlet components have a finite life, the cover/grate should be inspected frequently and replaced at least every ten years or if found to be damaged, broken, cracked, missing, or not securely attached.

⚠ WARNING – All suction and discharge valves MUST be OPEN when starting the circulation system. Failure to do so could result in severe personal injury and/or property damage. All drains and suction outlets MUST have properly installed covers, securely attached using the screws supplied with the covers. If screws are lost, order replacement parts from your supplier.



⚠ WARNING—Hazardous Pressure. Pool and spa water circulation systems operate under hazardous pressure during start up, normal operation, and after pump shut off. Stand clear of circulation system equipment during start up. Failure to follow safety and operation instructions could result in violent separation of the pump housing and cover due to pressure in the system, which could cause property damage, severe personal injury, or death. Before servicing pool and spa water circulation system, all system and pump controls must be in off position and filter manual air relief valve must be in open position. Before starting system pump, all system valves must be set in a position to allow system water to return back to the pool. Do not change filter control valve position while system pump is running. Before starting system pump, fully open filter manual air relief valve. Do not close filter manual air relief valve until a steady stream of water (not air or air and water) is discharged.



⚠ WARNING—Separation Hazard. Failure to follow safety and operation instructions could result in violent separation of pump components. Strainer cover must be properly secured to pump housing with strainer cover lock ring. Before servicing pool and spa circulation system, filter manual air relief valve must be in open position. Do not operate pool and spa circulation system if a system component is not assembled properly, damaged, or missing. Do not operate pool and spa circulation system unless filter air relief valve body is in locked position in filter upper body.

⚠ WARNING—Fire and burn hazard. Motors operate at high temperatures and if they are not properly isolated from any flammable structures or foreign debris they can cause fires, which may cause severe personal injury or death. It is also necessary to allow the motor to cool for at least 20 minutes prior to maintenance to minimize the risk of burns.

⚠ WARNING – Failure to install according to defined instructions may result in severe personal injury or death.

⚠ WARNING – The following “Safety Rules for Hot Tubs” recommended by the U.S. Consumer Product Safety Commission should be observed when using the spa.

1. Spa or hot tub water temperatures should never exceed 104°F [40°C]. A temperature of 100°F [38°C] is considered safe for a healthy adult. Special caution is suggested for young children. Prolonged immersion in hot water can induce hyperthermia.
2. Drinking of alcoholic beverages before or during spa or hot tub use can cause drowsiness, which could lead to unconsciousness and subsequently result in drowning.
3. **Pregnant women beware!** Soaking in water above 100°F. [38°C] can cause fetal damage during the first three months of pregnancy (resulting in the birth of a brain-damaged or deformed child). Pregnant women should adhere to the 100°F. [38°C] maximum rule.
4. Before entering the spa or hot tub, users should check the water temperature with an accurate thermometer; spa or hot tub thermostats may err in regulating water temperatures by as much as 4°F [2.2°C].
5. Persons taking medications, which induce drowsiness, such as tranquilizers, antihistamines or anticoagulants, should not use spas or hot tubs.

USE ONLY HAYWARD GENUINE REPLACEMENT PARTS

6. If the pool/spa is used for therapy, it should be done with the advice of a physician. Always stir pool/spa water before entering the pool/spa to mix in any hot surface layer of water that might exceed healthful temperature limits and cause injury. Do not tamper with controls, because scalding can result if safety controls are not in proper working order.
7. Persons with a medical history of heart disease, circulatory problems, diabetes or blood pressure problems should obtain a physicians advice before using spas or hot tubs.
8. Hyperthermia occurs when the internal temperature of the body reaches a level several degrees above normal body temperature of 98.6°F. [37°C]. The symptoms of Hyperthermia include: drowsiness, lethargy, dizziness, fainting, and an increase in the internal temperature of the body.

The effects of Hyperthermia include:

1. Unawareness of impending danger.
2. Failure to perceive heat.
3. Failure to recognize the need to leave the spa.
4. Physical inability to exit the spa.
5. Fetal damage in pregnant women.
6. Unconsciousness resulting in danger of drowning.

DEFINITIONS:

Suction Outlet – The term Suction Outlet is a fitting, fitting assembly, cover/grate and related components that provide a means for water to exit the pool and into the pump circulating system.

Inches of Mercury (in Hg) - A unit for measuring pressure below atmospheric (“suction” or “vacuum”) (1.0 inch Hg = .491 PSI)

Main Drain – See Suction Outlet

PSI – An abbreviation for pounds per square inch.

INSTALLATION:

Materials needed for Installation

The following items are needed and supplied by the installer for all heat pump installations.

1. Plumbing connections:
2 inch PVC pipe Schedule 40 and 2 inch fittings and components as follows:
 - (3) - 2 inch Isolation Valves
 - (1) - 2 inch Check Valve
 - (2) - 2 x 2 x 2 PVC Tee's

NOTE: Pipe fittings such as reducers, tees, and elbows cause pressure to drop as water flows through them. Plan the plumbing layout carefully, using as few fittings as possible to connect your heat pump. See plumbing diagram under the heading “Plumbing Specifications and Layout” for more information.

2. Level surface for proper draining.
3. Suitable electrical supply line. See rating plate on the heat pump units for electrical specifications. A junction box is not needed at the heat pump; connections are made inside the heat pump electrical compartment. Minimum wire size to be selected per NEC SEC.440.33 based on unit MCA.
4. Electric disconnect switch that will interrupt all power to the unit. This switch MUST be within line of sight of the heat pump.

USE ONLY HAYWARD GENUINE REPLACEMENT PARTS

Hayward HeatPro Heat Pump Dimensions

MODELS: HP20654T, HP20654BT, HP20854T, HP20854BT and HP21104T

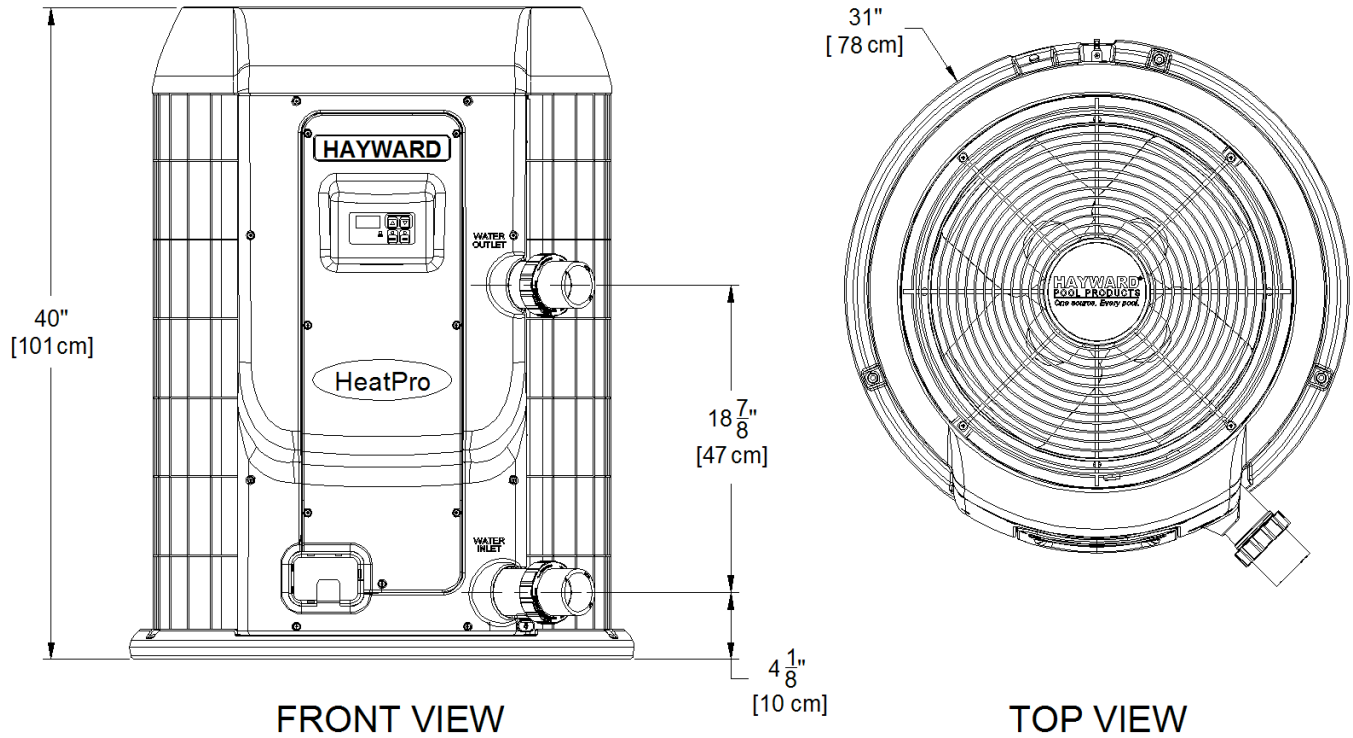

Hayward HeatPro Heat Pump Specifications

Operating Specification	HP20654T & HP20654BT	HP20854T & HP20854BT	HP21104T
Volts	240	240	240
Hertz	60	60	60
Phase	1	1	1
Compressor Maximum Operating Current	17.9A	28A	27A
Compressor LRA	112A	135A	145A
Fan Motor Max Load (Amps)	2.8A	2.8A	2.8A
Fan Motor HP	1/3	1/3	1/3
Minimum Circuit Ampacity	24	36	35
Maximum Fuse Size (Amps)	40	60	60
Refrigerant	R-410A	R-410A	R-410A
Min. Water Flow Rate (GPM)	30	30	30
Max. Water Flow Rate (GPM)	75	75	75
Maximum Water Temperature	104°F	104°F	104°F

USE ONLY HAYWARD GENUINE REPLACEMENT PARTS

Installation Specifications

Receipt Inspection of Heat Pump Unit

The carton bears specific warnings stating “DO NOT DROP OR TAILGATE”, as well as arrows indicating the correct vertical positioning. **THE HEAT PUMP MUST NOT BE TIPPED OR TRANSPORTED ON ITS SIDE AS EVAPORATOR “OIL LOGGING” MAY OCCUR.** Inspect the heat pump carton upon receipt for possible damage in shipment. A punctured or oil-soaked area of the carton could indicate damage to the sealed refrigeration system. If damage has occurred or is suspected, bring it to the immediate attention of the delivery carrier.

Upon arrival at the installation site, the heat pump unit should be carefully unpacked and inspected for any damage that may have occurred in transit. Minor indentations to the aluminum evaporator fins will not affect performance of the heat pump unit.

**THE MANUFACTURER CANNOT ACCEPT RESPONSIBILITY FOR
DAMAGE INCURRED OR REPAIRS NECESSITATED DUE TO IMPROPER
HANDLING OF OUR EQUIPMENT**

Location - Determining Optimum Location

THE LOCATION OF THE HEAT PUMP IS VERY IMPORTANT FOR EFFICIENT OPERATION.

In order of importance, the installer must consider the following conditions:

- The heat pump will perform more efficiently when placed in **direct** sunlight.
- Ample air intake with avoidance of air re-circulation
- Accessibility of service panels

NOTICE - DO NOT install the heat pump unit in a fully enclosed space (i.e. garage, shed etc). Failure to follow this instruction may result in poor performance, property damage, and voided warranty.

USE ONLY HAYWARD GENUINE REPLACEMENT PARTS

Placement / Clearances

All criteria given in the following sections reflect minimum clearances. However, each installation must also be evaluated, taking into account the prevailing local conditions such as proximity and height of walls and public access areas.

The heat pump must be placed to provide clearances on all sides for maintenance and inspections.

1. A minimum of 24 in [61 cm] of clearance on all sides.
2. If the heat pump is to be installed under a cover or vertical overhang, the unit must have a minimum of 72 in. [183 cm] of clearance from the top of the heat pump to the bottom of the cover or overhang.
3. Install the heat pump a minimum of 60 in. [1.5 m] from the inside wall of the pool, spa, solid fence, or permanent barrier. Canadian installations require a minimum of 120 in. [3 m] of clearance from pool water.

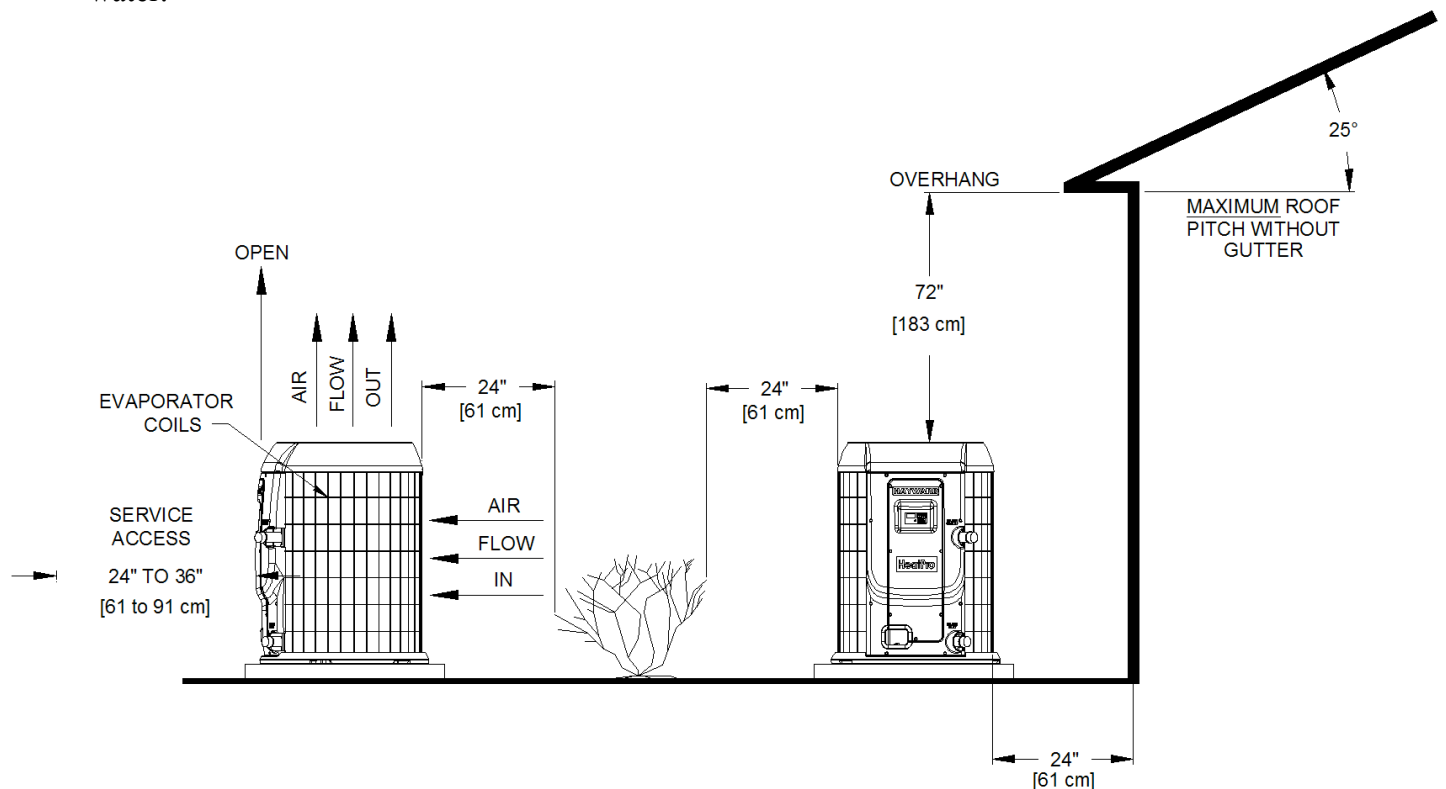

⚠ CAUTION - Make sure the heat pump is not located where large amounts of water may run-off from the roof into the unit. Sharp sloping roofs without gutters will allow massive amounts of rainwater, mixed with debris from the roof to be forced through the unit (see above diagram). Failure to follow the instructions may result in property damage and a voided warranty.

NOTE: A gutter or down spout may need to be installed to protect the heat pump.

Equipment Pad

Place the heat pump on a level surface such as concrete or a fabricated slab (pad). This allows proper drainage of condensation and rainwater from the base of the unit. If possible, the pad should be placed at the same level or slightly higher than the filter system equipment pad.

USE ONLY HAYWARD GENUINE REPLACEMENT PARTS

Drainage and Condensation

Condensation will be produced by the evaporator coil when the unit is running and drain at a steady rate, usually three to five gallons per hour, depending upon ambient air temperature and humidity. The more humid the conditions, the more condensation will be produced. Keep the drain hole, located at the rear of the bottom pan of the base of the unit, clear of debris. A drain hose/line may be attached to the drain hole in the base pan to help direct drainage away from the unit.

NOTICE

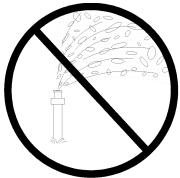

Make sure there are no sprinkler heads near the heat pump that will spray on or into the unit. **Sprinkler damage is not covered under the warranty agreement.**

Make sure that sprinklers are placed at a sufficient distance away, so that normal wind will not carry the mist to the heat pump. If the filtering system area has plants that need water, use a trickle type irrigation sprinkler instead of the broadcast type

The heat pump is designed to handle the wettest weather conditions that are typical of rain and high humidity. Sprinkler heads force high-pressure water into the unit from the side at an odd angle. Many sprinkler systems are connected to a well system, whose water is high in minerals, sulphur and other aggressive contaminants, that will leave a build up on the evaporator coils and electronics causing corrosion and hampering efficiency. If your location is within 15 miles of the coast, salt may also be in the well water.

NOTICE - If located in an oceanfront area, the heat pump should be placed out of direct spray of sand and salt. **This will clog, damage, and corrode the unit.** You may also consider protecting the unit by planting shrubbery or installing a privacy fence between the unit and the prevailing beachfront wind. **Damage caused by sand or salt spray is not covered by the warranty.**

USE ONLY HAYWARD GENUINE REPLACEMENT PARTS

Anchoring

Anchor Installation

Follow all relevant Local, State and National requirements regarding wind load anchoring. When anchoring is required to secure the heat pump to concrete pad, use the specified hardware shown in the diagrams below.

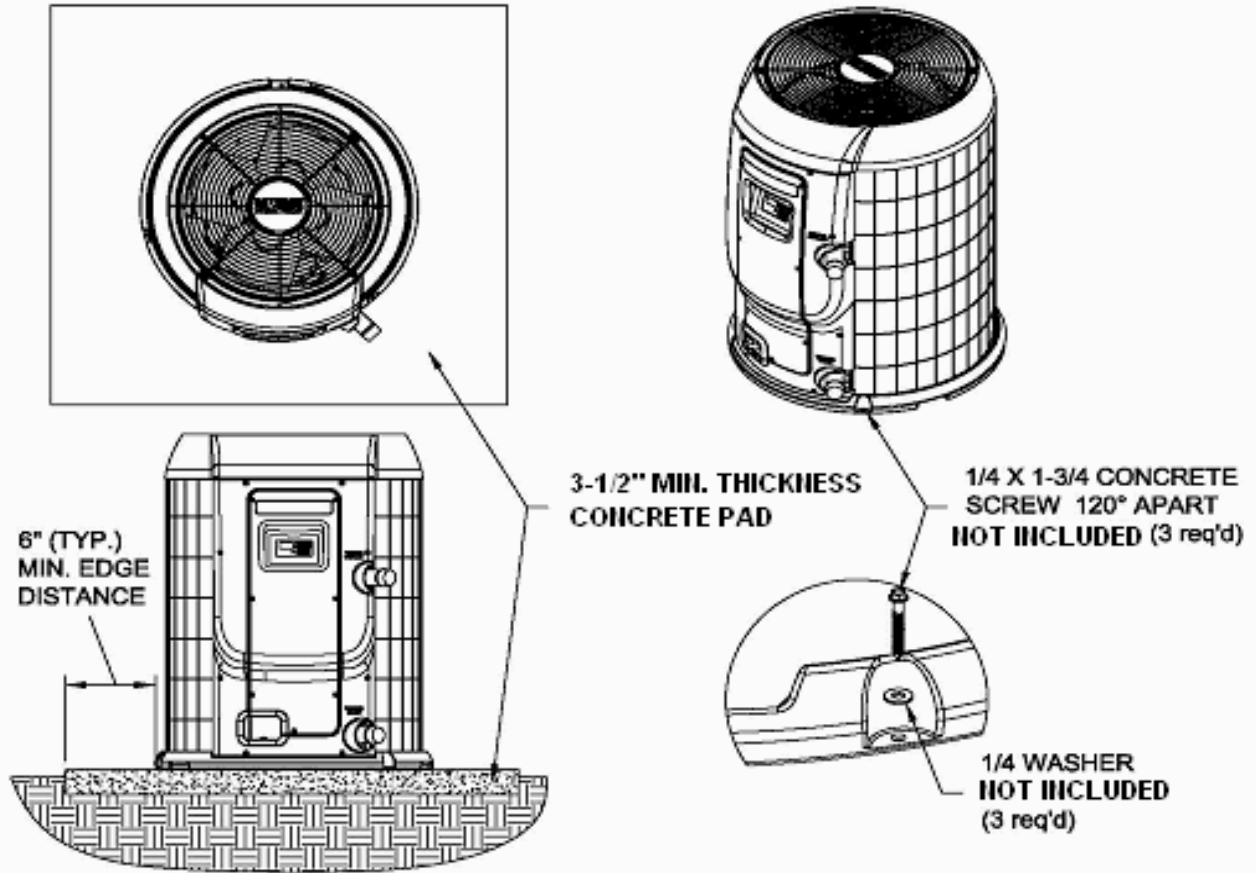

**Use this diagram to tie-down Heat Pump Models:
HP20654T, H20654BT, HP20854T, HP20854BT & HP21104T**

USE ONLY HAYWARD GENUINE REPLACEMENT PARTS

Plumbing Specifications and Layout

The figure below illustrates the standard plumbing layout with a single heat pump unit.

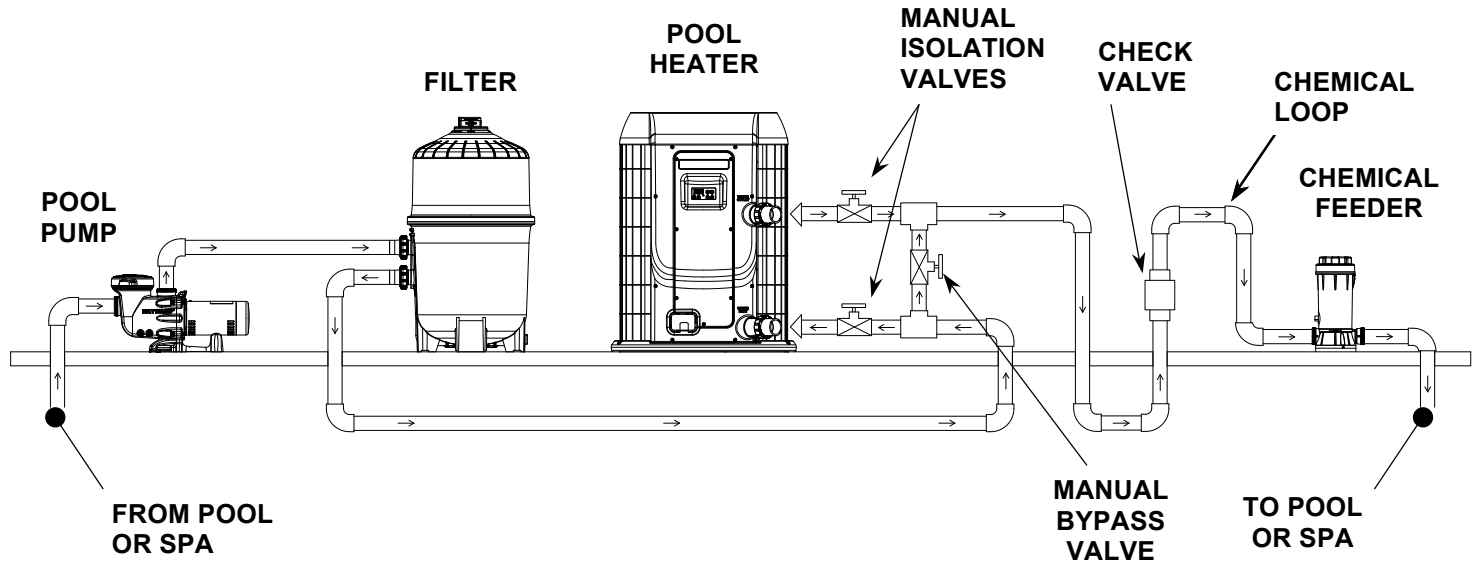

NOTICE -The heat pump must be protected from back siphoning of water. If there is any chance of back siphoning, provide a check valve between the pool and the filter pump inlet. Failure to follow the instructions may result in property damage due to flooding.

NOTICE -Automatic erosion type chlorinators, if used, must be installed downstream (between the heat pump and the pool) of the heat pump, and a check valve (or Hartford Loop) installed in a manner that will not allow the raw chlorine to drain back to the heat pump when the water pump is off. Failure to follow the instructions may result in property damage.

NOTICE - **Do not pour chemicals directly into the skimmer. It could result in damage to your system and heat pump.**

Arrangement of pool system components other than as illustrated previously and in the following diagrams can affect the operation of the heat pump's water pressure switch. Location of the heat pump above or below the elevation of the pool water surface can also affect operation of the switch. In general, the pressure switch can be adjusted to accommodate this effect if the heat pump water connections are no more than six (6) feet [1,8 m] below the pool water surface or no more than fifteen (15) feet [4,6 m] above it. See instructions for pressure switch adjustment in the heat pump start up section of this manual. If the heat pump is installed outside of this range, an external pressure switch may need to be installed in the plumbing upstream of the heat pump. For more information call Hayward Technical Service at 908 355-7995.

Be advised, that when pool equipment is located below the pool surface, a leak can result in large-scale water loss or flooding. Hayward is not responsible for water loss, flooding or damage caused by either occurrence.

USE ONLY HAYWARD GENUINE REPLACEMENT PARTS

NOTICE - When the piping installation is complete, operate the pool filter pump *with the heat pump off*. Check the entire piping system for leaks. Observe the filter water pressure gauge for abnormalities or obstructions in the filtering system. Failure to follow the instructions may result in property damage.

Flow Rate

MODEL: HP20654T & HP20654BT

This heat pump is designed for minimal water flow of 30 gpm to ensure sufficient heat removal from the condenser, thus avoiding overheating the unit. Flow rates above 75 gpm will begin to create excessive pressure drop through the condenser and require unnecessarily high pumping energy.

MODELS: HP20854T & HP20854BT

These heat pumps are designed for nominal water flows of 34 gpm through the condenser. A minimum flow of 30 gpm is required to ensure sufficient heat removal from the condenser, thus avoiding overheating the unit. Flow rates above 75 gpm will begin to create excessive pressure drop through the condenser and require unnecessarily high pumping energy.

MODELS: HP21104T

These heat pumps are designed for nominal water flows of 47 gpm through the condenser. A minimum flow of 30 gpm is required to ensure sufficient heat removal from the condenser, thus avoiding overheating the unit. Flow rates above 75 gpm will begin to create excessive pressure drop through the condenser and require unnecessarily high pumping energy.

External Bypass

The heat pump is designed for a maximum flow rate of 75 GPM. An External Bypass Assembly can be added to regulate the flow rate through the heat exchanger to prevent damage. **Failure to install an External Bypass Assembly with a flow rate of 75 GPM or higher will void the warranty.**

USE ONLY HAYWARD GENUINE REPLACEMENT PARTS

Unions

Two detachable union connectors, (2 union nuts and 2 gaskets) included with the heat pump, **must** be installed on the heat pump water inlet and outlet to facilitate servicing and winterizing the unit. (See figure below).

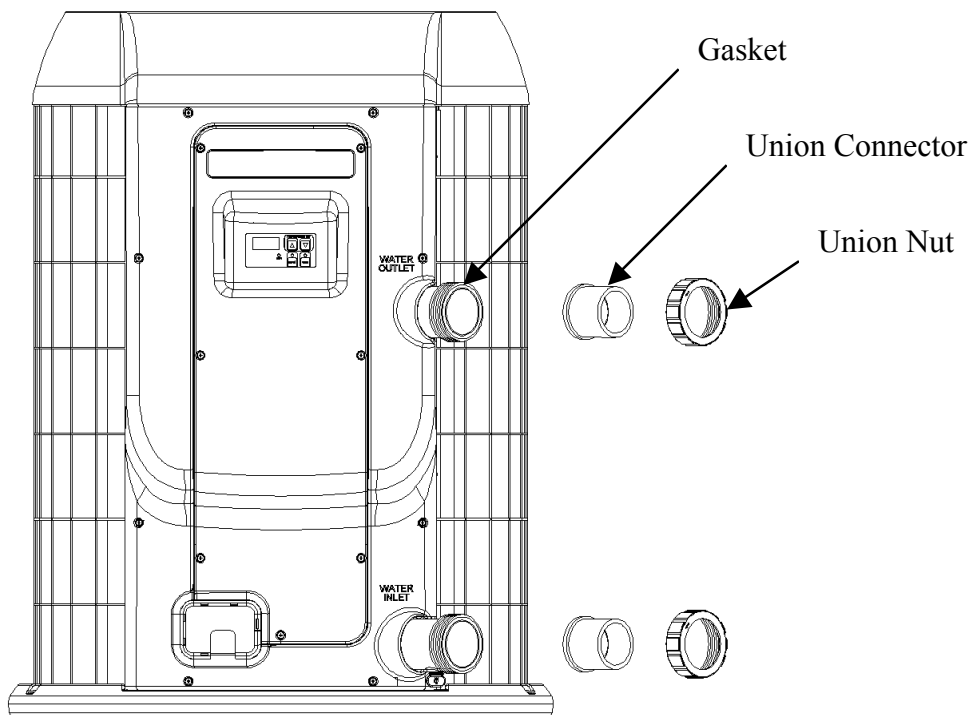

Installation of Pool Heat Pump Above Pool Surface

If the pool heat pump is installed more than three (3) feet [0,9 m] above the surface of the pool water, install directional flow fittings (not included with heat pump) on the end of the return water line to the pool. This will create adequate backpressure at the heat pump to operate the water pressure switch.

In some cases, such as when the heat pump is installed 6-8 feet [1,8 – 2,4 m] above the pool surface, it may be necessary to install a positive flow switch in the waterline instead of the pressure switch.

Installation of Pool Heat Pump Below Pool Surface

A water pressure switch is integrated into the system to ensure that the unit only operates when water is flowing through the heat exchanger. If the heat pump is installed below the pool surface, the backpressure of water from the pool can cause problems with the internal water pressure switch setting. The water pressure switch is located in the control panel of the heat pump. Adjustment knob – counterclockwise decreases pressure set point, adjustment knob – clockwise increases the set point.

Backpressure from the pool can close this switch, whose function is to tell the heat pump that the filter pump is running. This pressure switch setting should be adjusted so that the heat pump is running only while the pool filter pump is operating.

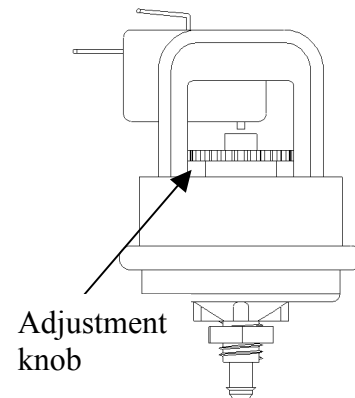

USE ONLY HAYWARD GENUINE REPLACEMENT PARTS

NOTICE - If the heat pump runs for more than a couple of minutes without the filter pump running, the unit can become overheated and damaged. After adjusting the pressure, turn off pool pump to ensure the heat pump does not run. It is possible for water to flow through the heat pump without operating the heat pump.

Installation of Multiple Heat Pumps

If a heat pump pool heater sizing calculation indicates that *two or more heat pumps* are required to heat a single pool, the units are to be *installed for parallel operation*. Series plumbing reduces efficiencies of each heat pump downstream.

The figure below shows **installation of multiple units in parallel**. Contact Hayward Technical Service if installing more than two units.

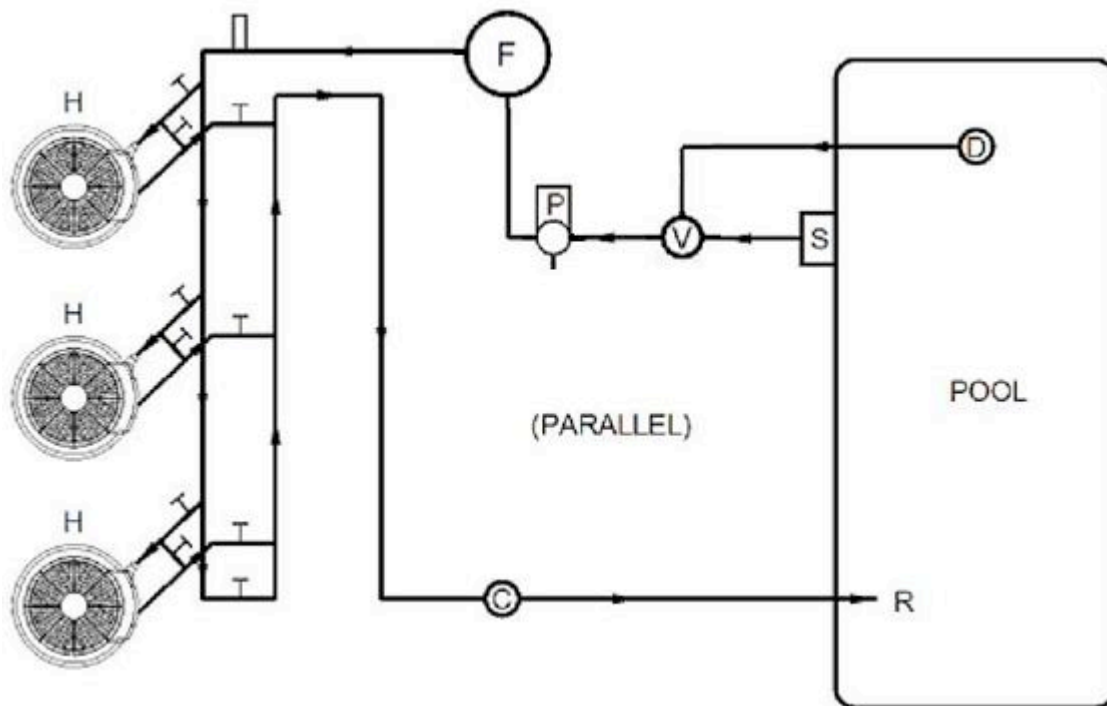

Notes:

1. Maintain 4-6 ft [1,2-1,8 m] clearance between the units, 2 ft [0,6 m] around them, and at least 6 ft [1,8 m] over them. Refer to the pages 7 & 8 for more information.
2. Install bypass loops for each unit.
3. Install union style fittings from the heat pump KIT adjacent to the unit to facilitate easy service procedures.

USE ONLY HAYWARD GENUINE REPLACEMENT PARTS

Installation in Combination with Solar or Gas Heaters

If you are installing a heat pump in combination with any other type of heating device, please call the HAYWARD service department at (908) 355-7995. We will advise you of installation practices that will help keep your warranty valid.

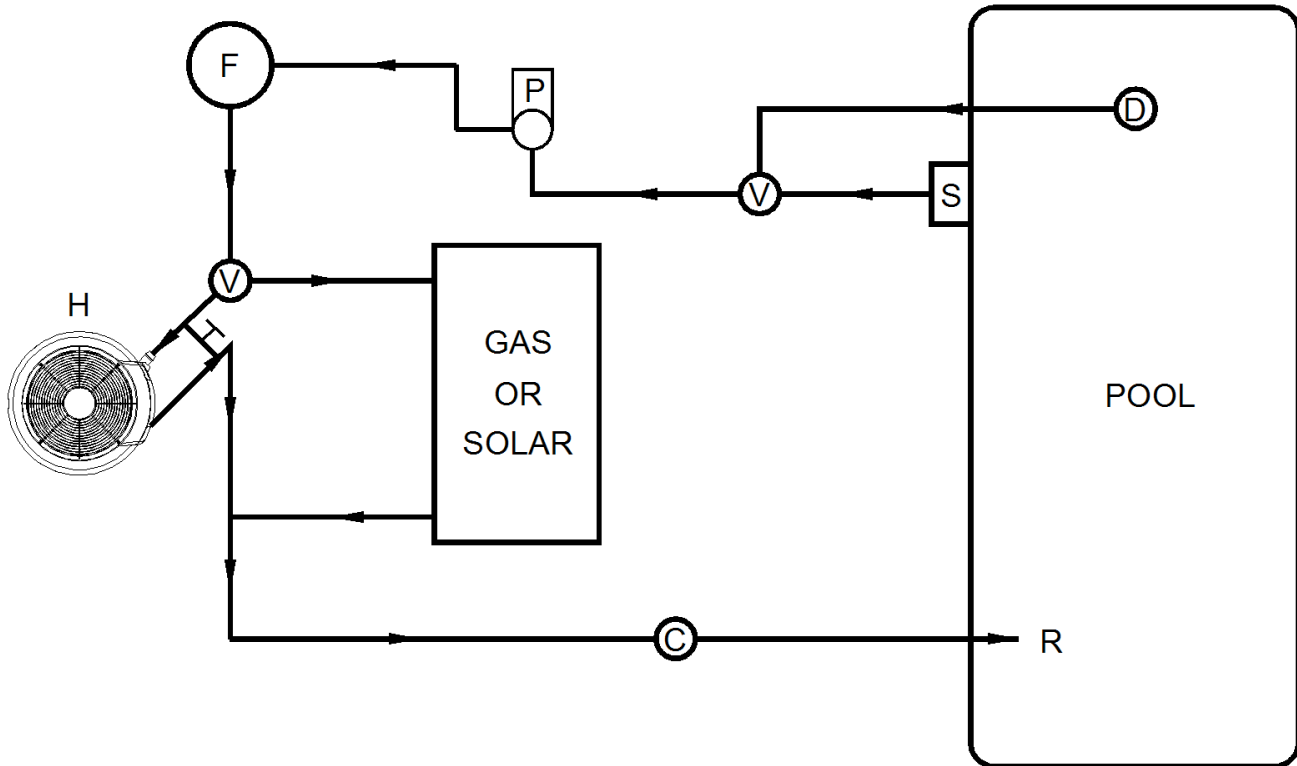

Other pool heaters, such as gas-fired or solar-powered devices *must be installed in a parallel circuit and operated independently (only one at a time) for your warranty to stay valid.*

NOTICE - Because of the intense heat that can be generated by gas and solar units, isolating it with a shut-off valve and a check valve when gas or solar heater is in operation protects the heat pump. Failure to follow the instructions may result in property damage.

Notes:

1. Isolate the heat pump from hot water flow of heating devices such as gas or solar heater.
2. Install bypass loop for Hayward heat pump unit.

Electrical Specifications



⚠ WARNING - RISK OF ELECTRICAL SHOCK OR ELECTROCUTION

Failure to follow the instructions may result in permanent injury or death.

All electrical wiring **MUST** be in conformance with all applicable local codes, regulations and the National Electric Code (NEC). Ground and bond the heat pump before connecting to electrical power supply. Failure to bond the heat pump can cause serious or fatal electrical shock hazard. **DO NOT** ground to a gas supply line. To avoid dangerous or fatal electrical shock, turn OFF power to the heat pump before working on electrical connections.

USE ONLY HAYWARD GENUINE REPLACEMENT PARTS

⚠WARNING - This heat pump contains wiring that carries high voltage. Contact with these wires could result in personal injury or death to pool or spa users, installers, or others due to electrical shock, and may also cause damage to property. Always disconnect power circuit before connecting the heat pump, or working on the heat pump. Failure to follow the instructions may result in personal injury or death.

⚠WARNING - Label all wires prior to disconnection when servicing controls. Wiring errors can cause improper and dangerous operation. Verify proper operation after servicing. Failure to follow the instructions may result in personal injury or death.

General Information

⚠WARNING - Wiring connections must be made as shown in the wiring diagram found on the inside of the heat pump access panel. The heat pump must include a definite means of grounding and bonding. There is a ground lug inside the heat pump electrical compartment and a bonding lug on the rear of the heat pump base pan. Failure to properly make wiring terminations may result in personal injury.

Main Power

⚠WARNING - All electrical wiring **MUST** be in conformance with all applicable local codes, regulations and the National Electric Code (NEC), in particular NEC Article 680: *Swimming Pools, Fountains & Similar Installations* and Article 440: *Air-Conditioning & Refrigeration Equipment*.

The preceding standards govern the installation of all heat pumps. HeatPro™ heat pumps are designed and safety tested by a certified laboratory to be installed under applicable standards detailed within the NEC.

Hayward does not recommend the use of ground fault protective devices in conjunction with heat pumps. Service calls, found to be due to “nuisance” tripping of ground fault devices, are not covered under the factory warranty.

⚠CAUTION - An outdoor waterproof disconnect should be mounted adjacent to the heat pump for safety.

The data plate is located on the front cover of each unit in the position illustrated in the figures above. Refer to the unit data plate for specific electrical power and over current protection device requirements. Based on data plate information, wire sizing, and over current protection devices per above codes and standards.

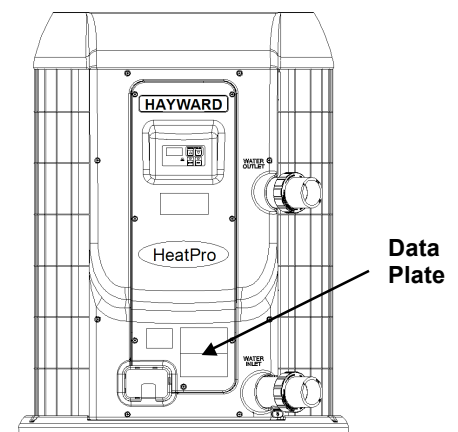

Bonding

⚠CAUTION - This heat pump must be connected to a bonding grid with a solid copper conductor wire gauge 8 AWG or larger to comply with Article 680 of the NEC. All Hayward heat pumps are designed for copper conductors only.

The National Electrical Code (NEC) in Article 680, and most other codes require that all metallic components of a pool structure, including reinforcing steel, metal fittings and above ground equipment, be bonded together with a solid copper conductor wire gauge 8 AWG or larger. The heat pump, along with pumps and other pool

USE ONLY HAYWARD GENUINE REPLACEMENT PARTS

equipment must be connected to this bonding grid. A bonding lug is provided on the rear of the base pan of the heat pump to facilitate bonding.

Wiring Diagrams

Refer to the following wiring diagrams for electrical connections.

This wiring diagram is for use with all units that have *dual digital thermostats without Time Clock Override*.

Models: HP20654T, HP20654BT, HP20854T, HP20854BT & HP21104T

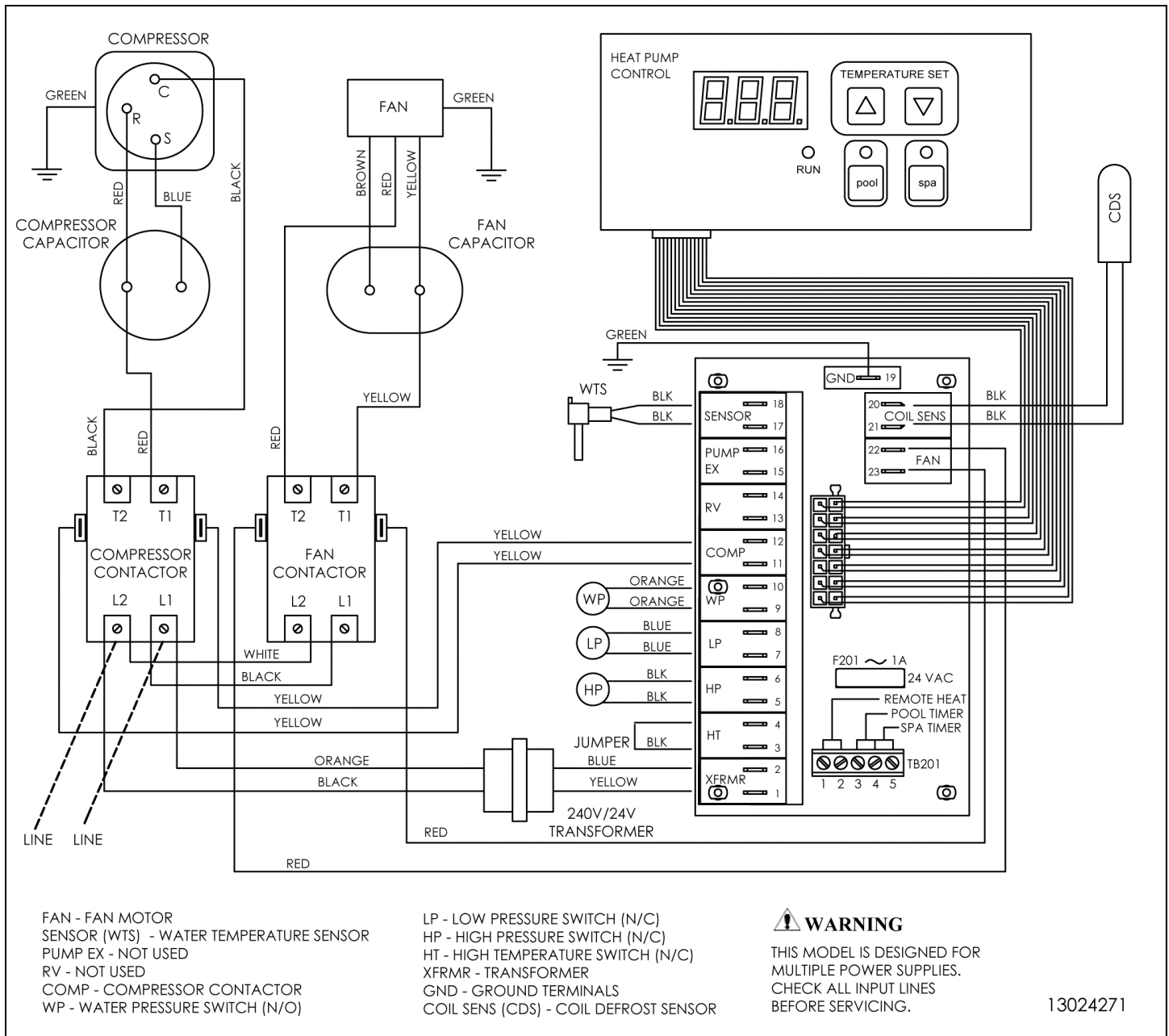

USE ONLY HAYWARD GENUINE REPLACEMENT PARTS

Connecting to Remote Systems

HAYWARD heat pumps are compatible, in the heating mode only, with one or more of the remote systems in the pool and spa industry today.

Thoroughly read all installation instructions of the remote system before connecting this unit.

The figure below shows the remote systems connections to the HAYWARD heat pump.

Connection to Compatible Remote Systems:

- Connect two wires (24 VAC) from the remote system. In the TB201 Terminal Block of the Interface board, connect one wire into terminal 1, and the other into terminal 2.
- The thermostat on the heat pump must be in the “Standby” mode for the remote system to control the unit.

Or

- Connect three wires marked as *pool*, *spa*, and *common* from the remote system to TB201 Terminal Block as follows:

Terminal 3 = Pool

Terminal 4 = Common

Terminal 5 = Spa

- The thermostat on the heat pump must be in the “Standby” mode for the remote system to control the unit.
- The thermostat on the heat pump will control the water temperature.

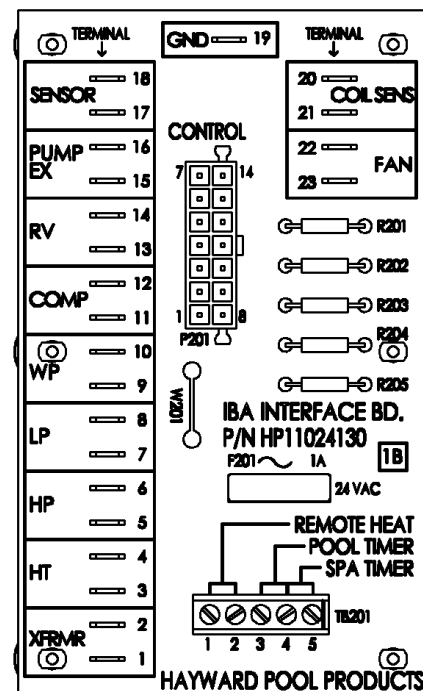

Thermostat Interface Board in the unit
Control Box

Initial Start-Up

After completing the electrical and piping connections to the pool heater, follow the procedures outlined below to ensure that the pool heater is functioning properly.

Before proceeding, **MAKE CERTAIN** there are no air or water leaks in any plumbing connections or piping and water flow is within the proper flow rate ranges. The proper flow rate ranges for ALL Hayward HeatPro Heat Pumps are a minimum of 30 GPM and a maximum of 75 GPM.

Note: Damage caused by flow rates outside this range will void the warranty.

CAUTION - Keep all objects off the top of the heat pump. Blocking airflow could damage the unit and will void the warranty.

USE ONLY HAYWARD GENUINE REPLACEMENT PARTS

Start-Up Procedures

1. Apply power to the pool heater by plugging in the non-fused disconnect block or moving the circuit breaker to the “ON” position.
2. Place the pool heater thermostat in the “Standby” mode by ensuring the light above the “POOL” button (and “SPA” button for dual thermostat application) is not illuminated. If the light(s) are lit, depress the “POOL” button (and “SPA” button for dual thermostat application) to put the unit in “STANDBY” mode.
3. Make sure the pool filter pump is operating properly.
4. Push the “POOL” button to activate the unit and then set the pool Heat Pump thermostat to a temperature higher than the current pool water temperature.
5. Allow 5 Minutes for the Heat Pump to start.
6. When the unit starts, confirm that air is being discharged upward from the unit and the air is cooler than the ambient air.
7. Allow the Heat Pump to operate for 10-15 minutes in order for system pressure to stabilize.
8. Using a thermometer, ensure that the discharge air is at least 8°F (4°C) cooler than the ambient air temperature. If discharge air does not have at least an 8°F (4°C) temperature change, refer to Performance Monitoring / Troubleshooting section in this manual.
9. If Heat Pump fails to start:
 - a) Check water flow
 - b) Ensure that power is On
 - c) Refer to Performance Monitoring Section of this Manual

Performance Maintenance and Troubleshooting

Installation Check: Verify the heat pump installation is compliant per this installation manual. Verify the electrical connection is correct by ensuring the breaker is sized correctly and the wiring is per the National Electric Code (NEC). Reference this installation manual to ensure that the plumbing is installed correctly.

Circuit Breakers: If it is suspected that a circuit breaker may be tripped, turn the breaker to the “Off” position and then back to the “On” position.

NOTICE: Service to be conducted **ONLY** by an EPA Certified Service Technician.

USE ONLY HAYWARD GENUINE REPLACEMENT PARTS

General Troubleshooting Guide for Hayward HeatPro Heat Pump			
Problem	Possible Cause	Possible Solution(s)	
Unit is not operating.	No power to unit	Make sure power is on.	
	Breaker is tripped	Check the breaker / see note above	
	Thermostat not turned up high enough	Turn thermostat up until unit comes on	
	5 minute delay timer still running	Be sure the 5 minute delay has passed	
	Low water flow	Make sure filter is clean	
		Make sure filter pump is on	
		Unhook cleaning devices	
Outside temperature too low	Check outside ambient temperature or wait for warmer temperatures to operate. (refer to Operating section)		
Fan not functioning	Call for service.		
Heat pump is running but is not heating, "Run" light does not come on.	Check output air temperature to input air temperature. Differential should be at least 8°F (4°C)	Low ambient air temperature. Allow outside air temperature to exceed 60°F, then re-check	
	System Component failure.	Call for service.	
Heat pump runs continually	Thermostat set too high	Turn thermostat down	
	Electrical component failure	Turn off the filter pump. If the unit is still running after 2 minutes, turn off the power to the unit and call for service.	
Heat pump is cycling (on / off too quickly)	Bad valve or improper water flow	Check valve settings and ensure water flow is sufficient (is the filter pump running continually?) If heat pump continues to cycle, turn unit off to prevent compressor damage.	
	Low refrigerant, low ambient temp, or high humidity with low ambient temp	Check evaporator coil for severe frost. Turn unit off to prevent compressor damage.	
		If heat pump continues to cycle, turn unit off to prevent compressor damage.	
Water is coming from bottom of unit	Condensation	This is normal and there is no reason to be concerned	
	Possible water leak	Turn the unit off for several hours, but leave the filter pump running continuously. If water quantity decreases, then it is only condensation. Otherwise there is a possible leak.	

USE ONLY HAYWARD GENUINE REPLACEMENT PARTS

Display Diagnostic Codes -Troubleshooting Guide for Hayward HeatPro Heat Pump			
Display	Problem	Possible Cause	Solution
(blank)	No power to heat pump	Tripped circuit breaker/ no power supply	Check breaker and ensure that the unit is properly installed.
	Faulty electrical component		Call for service.
	Unit will not turn on	5-minute delay	Wait 5 minutes.
PS	Water Pressure Switch	Low or no water flow	Check water flow to heat pump.
			Clean your filter
			Make sure all valves are fully open and bypass valve is closed.
			Ensure pool filter pump is on.
			Normal operation for TCO function
		Turn off fountains, etc.	
LP	Low Pressure Switch	Air flow obstruction	Call for service.
		Low Ambient Temperature cutoff	Wait for outside temperature to reach 60°F.
HI	High Pressure Switch	Low water flow	Check water flow to heat pump.
			Clean your filter
			Make sure all valves are fully open and bypass valve is closed.
		Ensure pool filter pump is on and turn off fountains.	
		High water temp	Set unit to "ACP" if using heat / cool option. Refer to text on HP3100 control board.
Check pool temp. Wait until pool needs heat.			
		Call for service.	
SH	Temperature sensor	Failure	Call for service.
OP	Temperature sensor	Failure	Call for service.
888	Thermostat reset	Normal operation	Temporary display. Shows for 1-2 seconds when the unit is first turned on.
rhd	Remote heat demand	Remote device is controlling the unit.	Refer to owner's manual of the remote device.
			If a remote device is not connected, call for service.
PST	Push button stuck	Release button is stuck.	If button does not release. Call for service.
PNL	Control not receiving data from panel	Control communication problem.	Call for service.
CEL	Panel not receiving data from control	Control communication problem.	Call for service.
CHC	Board self-check error	Board Failure	Call for service.
dEF	Defrost Mode	Frost build up on evaporator coil.	No action required. Unit is defrosting automatically.
cOP	Coil Sensor	Sensor Failure	Call for Service
cSH	Coil Sensor	Sensor Failure	Call for Service

USE ONLY HAYWARD GENUINE REPLACEMENT PARTS

USE ONLY HAYWARD GENUINE REPLACEMENT PARTS