

INSTALLATION & OPERATING INSTRUCTIONS

Atmospheric Above-Ground Pool & Spa Heater (Chauffe-Piscine)

Models 106 & 156

English/French



WARNING: If the information in these instructions are not followed exactly, a fire or explosion may result causing property damage, personal injury or death.

FOR YOUR SAFETY: Do not store or use gasoline or other flammable vapors and liquids or other combustible materials in the vicinity of this or any other appliance. To do so may result in an explosion or fire.

WHAT TO DO IF YOU SMELL GAS:

- Do not try to light any appliance.
- Do not touch any electrical switch; do not use any phone in your building.
- Immediately call your gas supplier from a neighbor's phone. Follow the gas supplier's instructions.
- If you cannot reach your gas supplier, call the fire department.

Installation and service must be performed by a qualified installer, service agency or the gas supplier.

AVERTISSEMENT: Assurez-vous de bien suivre les instructions données dans cette notice pour réduire au minimum le risque d'incendie ou d'explosion ou pour éviter tout dommage matériel, toute blessure ou la mort.

Ne pas entreposer ni utiliser d'essence ou ni d'autres vapeurs ou liquides inflammables à proximité de cet appareil ou de tout autre appareil.

CE FAIRE SI VOUS SENTEZ UNE ODEUR DE GAZ:

- Ne pas tenter d'allumer d'appareil.
- Ne touchez à aucun interrupteur; ne pas vous servir des téléphones se trouvant dans la bâtiment.
- Appelez immédiatement votre fournisseur de gaz depuis un voisin. Suivre les instructions du fournisseur.
- Si vous ne pouvez rejoindre le fournisseur, appelez le service des incendies.

L'installation et l'entretien doivent être assurés par un installateur qualifié ou par le fournisseur de gaz.

This manual should be maintained in legible condition and kept adjacent to the heater or in another safe place for future reference.

Rev. 5 reflects the following:

Changes to: "Unpacking" on page 7, "Gas Connections" on page 13, Fig. 7 on page 14.

Additions: None

Deletions: None

CONTENTS

WARNINGS

Pay Attention to These Terms

WATER CHEMISTRY

Automatic Chlorinators &
Chemical Feeders

SAFETY

Water Temperature Safety

INTRODUCTION

Ratings & Certifications

Model Identification

Specifications

Unpacking

INSTALLATION

Installation Codes

Installation Codes

Clearances

Base Installation

Outdoor Installation

Indoor Installation

Combustion & Ventilation Air

Gas Connections

Water Connections

Electrical Connections

OWNER'S OPERATING

INSTRUCTIONS

Control Adjustments—Analog

Control Adjustments—Digital

4	Thermostat Operation—Advanced Flame	
4	Technology (AFT) Board	20
5	Status and Diagnostics	22
	Remote Control Installation	23
5	Wiring Diagrams	25
6	Post Start-Up Inspection	26
6	Cold Weather Operation	26
6	MAINTENANCE	27
6	SERVICE	27
7	Water Pressure Switch	27
7	Flame Roll-Out Safety Switch	28
7	High Limits	28
8	Burner Tray Removal	29
9	Gas Valve Removal	29
10	Pilot Removal & Cleaning	30
10	Heat Exchanger Removal	31
10	Tube Cleaning Procedure	31
10	De-sooting Procedure	31
12	Replacement Parts	31
12	TROUBLESHOOTING	32
13	Mechanical	32
15	Electronic Control Logic Flowchart	33
17	Analog Control Logic Flowchart	34
	ILLUSTRATED PARTS LIST	35
18		
18		
18		

WARNINGS - Pay Attention to These Terms

DANGER:	Indicates the presence of immediate hazards which will cause severe personal injury, death or substantial property damage if ignored.
WARNING:	Indicates the presence of hazards or unsafe practices which could cause severe personal injury, death or substantial property damage if ignored.
CAUTION:	Indicates the presence of hazards or unsafe practices which could cause minor personal injury or product or property damage if ignored.
NOTE:	Indicates special instructions on installation, operation, or maintenance which are important but not related to personal injury hazards.

DANGER: Failure to install the draft hood on indoor installation and properly vent the heater to the outdoors as outlined in the venting section of this manual can result in unsafe operation of the heater. To avoid the risk of fire, explosion, or asphyxiation from carbon monoxide, never operate this heater unless it is properly vented and has an adequate air supply for proper operation. Be sure to inspect the vent system for proper installation at initial start-up, and at least annually thereafter. Refer to the venting section of this manual for more information regarding vent system inspections.

WARNING: To minimize the possibility of improper operation, serious personal injury, fire, or damage to the heater:

- Always keep the area around the heater free of combustible materials, gasoline, and other flammable liquids and vapors.
- Heater should never be covered or have any blockage to the flow of fresh air to the heater.

WARNING: Improper installation, adjustment, alteration, service, or maintenance can cause property damage, personal injury or loss of life. Refer to the owner's operating instructions provided in this manual. Installation and service must be performed by a qualified installer, service agency, or the gas supplier.

WARNING: Gasoline, as well as other flammable materials and liquids (adhesives, solvents, etc.), and the vapors they produce, are extremely dangerous. Do not handle, use, or store gasoline or other flammable or combustible materials in the vicinity of a heater.

WARNING: Both natural gas and propane have an odorant added to aid in detecting a gas leak. Some people may not physically be able to smell or recognize this odorant. If you are unsure or unfamiliar with the smell of natural gas or propane, ask your local gas supplier. Other conditions, such as "odorant fade," which causes the odorant to diminish in intensity, can also hide, camouflage, or otherwise make detecting a gas leak by smell more difficult.

WARNING: UL recognized fuel gas detectors are recommended in all enclosed propane and natural gas applications wherein there is a potential for an explosive mixture of fuel gas to accumulate and their installation should be in accordance with the detector manufacturer's recommendations and/or local laws, rules, regulations, or customs.

WARNING - CALIFORNIA PROPOSITION 65: This product contains chemicals known to the State of California to cause cancer, birth defects or other reproductive harm.

WARNING: Do not install within 3 feet (0.9 m) of a heat pump or an outdoor condensing unit. Strong air intake from this type of equipment can disturb the combustion process and cause damage or personal injury.

WARNING: The heater shall not be located in an area where water sprinklers, or other devices, may cause water to spray through the cabinet louvers and into the heater. This could cause internal rusting or damage electrical components, and void the warranty.

WATER CHEMISTRY

NOTE: Corrosive water voids all warranties.

Chemical imbalance can cause severe damage to your heater and associated equipment. Maintain your water chemistry according to Table A. If the mineral content and dissolved solids in the water become too high, scale forms inside the heat exchanger tubes, reducing heater efficiency and damaging the heater. If the pH drops below 7.2, this will cause corrosion of the heat exchanger and severely damage the heater. **Heat exchanger damage resulting from chemical imbalance is not covered by the warranty.**

For your health and the protection of your pool equipment, it is essential that your water be chemically balanced. The following levels must be used as a guide for balanced water.

CAUTION: Free chlorine must not exceed 5 ppm which can damage the heater and is not covered under warranty.

- Occasional chemical shock dosing of the pool or spa water should not damage the heater providing the water is balanced.

- Automatic chemical dosing devices and salt chlorinators are usually more efficient in heated water, unless controlled, they can lead to excessive chlorine level which can damage your heater.
- Further advice should be obtained from your pool or spa builder, accredited pool shop, or chemical supplier for the correct levels for your water.

Automatic Chlorinators & Chemical Feeders

All chemicals must be introduced and completely diluted into the pool or spa water before being circulated through the heater. **Do not place sanitizing chemicals in the skimmer. High chemical concentrations will result when the pump is not running (e.g. overnight).**

Chlorinators must feed downstream of the heater and have an anti-siphoning device to prevent chemical back-up into the heater when the pump is shut off. See Fig. 1.

NOTE: High chemical concentrates from feeders and chlorinators that are out of adjustment will cause rapid corrosion to the heat exchanger. Such damage is not covered under the warranty.

Recommended Level(s)	Fiberglass Pools	Fiberglass Spas	Other Pool and Spa Types
Water Temperature	68-88°F (20-31°C)	89-104°F (31-40°C)	68-104°F (20-40°C)
pH	7.3-7.4	7.3-7.4	7.6-7.8
Total Alkalinity (ppm)	120-150	120-150	80-120
Calcium Hardness (ppm)	200-300	150-200	200-400
Salt (ppm)	4500 Maximum	4500 Maximum	4500 Maximum
Free Chlorine (ppm)*	2-3	2-3	2-3
Total Dissolved Solids (ppm)	3000 Maximum**	3000 Maximum**	3000 Maximum**

*Free Chlorine **MUST NOT EXCEED 5 ppm!**

** In salt water chlorinated pools, the total TDS can be as high as 6000 ppm.

Table A: Water Chemistry

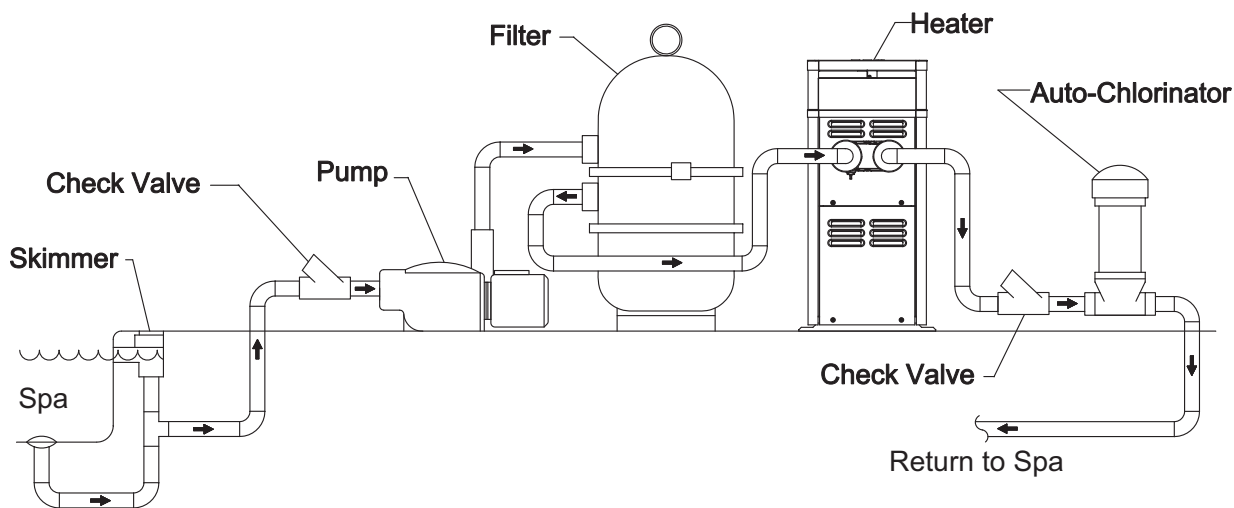

Fig. 1: Spa/Chlorinator Setup

SAFETY

This appliance is to be installed and operated by trained personnel in accordance with this Installation and Operation Manual. Be sure to read and understand the entire Installation and Operation Manual before attempting to install or operate this appliance. Failure to follow the warnings listed at the beginning of this manual could result in a fire or explosion, causing property damage, bodily injury, or death.

Should you have any problems understanding the warnings and instructions in this manual, STOP, and get help from a qualified installer, service technician, or the gas supplier.

Water Temperature Safety

Elevated water temperature can be hazardous. The U.S. Consumer Product Safety Commission has these guidelines:

1. Spa water temperatures should never exceed 104°F (40°C). A temperature of 100°F (38°C) is considered safe for a healthy adult. Special caution is suggested for young children.
2. Drinking of alcoholic beverages before or during spa or hot tub use may cause drowsiness which could lead to unconsciousness and subsequently result in drowning.
3. Pregnant Women Beware! Soaking in water over 102°F (39°C) may cause fetal damage during the first three months of pregnancy resulting in the birth of a brain-damaged or deformed child. Pregnant women should stick to the 100°F (38°C) maximum rule.

4. Before entering the spa or hot tub, users should check the water temperature with an accurate thermometer; spa or hot tub thermostats may err in regulating water temperatures by as much as 4°F (2.2°C).
5. Persons with a medical history of heart disease, circulatory problems, diabetes, or blood pressure problems should obtain a physician's advice before using spas or hot tubs.
6. Persons taking medications which induce drowsiness, such as tranquilizers, antihistamines, anticoagulants, or recreational drugs should not use spas or hot tubs.

AVERTISSEMENT: La U.S. Consumer Product Safety Commission indique que des températures de l'eau élevées peuvent être dangereuses. Voir la notice d'installation et de fonctionnement pour le réglage de la température. Suivre les instructions pour une installation appropriée.

INTRODUCTION

Ratings & Certifications

This pool & spa heater (chauffe-piscine) is design-certified and tested under the latest requirements of ANSI Z21.56 / CSA 4.7 Standard for Gas-Fired Pool Heaters (Chauffe-Piscines). The heater can be used either indoors or outdoors. (Installer à l'intérieur ou à l'extérieur.) If necessary, the top of the heater can be changed after installation to accommodate indoors or outdoors.

WARNING: Use of any parts not manufactured and/or approved by the manufacturer may cause non-warrantable damage.

Ambient Temperature Rating of Components

- Analog heater -40°F to +175°F (-40°C to 79.4°C)
- Electronic heater -32°F to +175°F (-35.5°C to 79.4°C)

Model Identification

The model identification number and heater serial number are found on the heater rating plate.

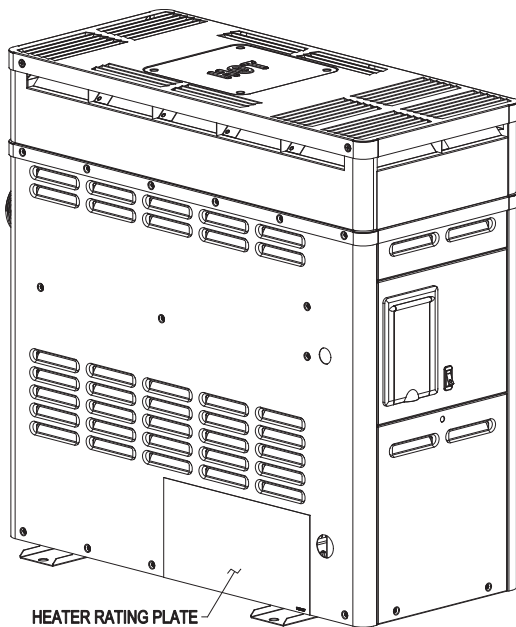
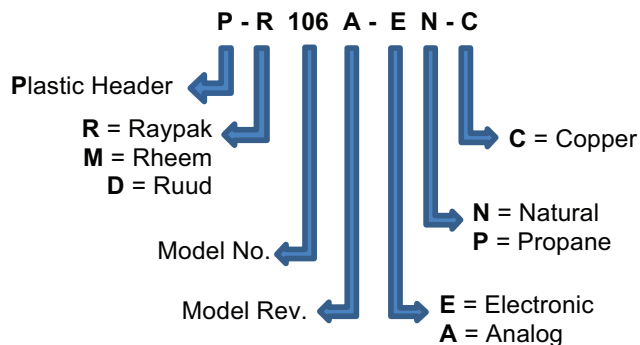

Fig. 2: Location of Heater Rating Plate

The model identification number will be similar to the example shown below:



Specifications

Model No.	Input*	Gas Conn. (NPT)	Water Conn. (NPT)	Shipping Weight	
				Std. Heater w/ Stackless Top	Drafthood Assembly
106	105,000 BTU/hr. (30.75 KW)	1/2 in. (1.27 cm)	1-1/2 in. or 2 in. (3.8cm or 5 cm)	85 lbs. (38.6 kg)	14 lbs. (6.35 kg)
156	150,000 BTU/hr. (43.93 KW)			100 lbs. (45.4 kg)	

Table B: Specifications

Unpacking

On receipt of the heater it is suggested that visual checks are made for external damage to the shipping carton. If the carton is damaged, make a note to that effect on the Bill of Lading when signing for the shipment. Remove the heater from the shipping packaging. Report any damage to the carrier immediately.

These items are shipped inside a bag in the carton with the heater:

1. 2" CPVC union with "O" rings (2)
2. Plastic pipe finish flange for gas line
3. Bonding lug with mounting screw
4. IOI Manual

On occasion, items are shipped loose. Be sure that the correct number of packages are received, as indicated on the Bill of Lading.

Claims for shortages and damages must be filed with the carrier by consignee. Authorization to return goods must be received from the factory prior to shipping. Goods returned to the factory without an authorized Returned Goods Receipt number will not be accepted. All returned goods are subject to a restocking charge.

When ordering parts, specify the model and serial number of the heater. When ordering under warranty conditions, specify the date of installation. Records of the installation must be provided, when requested, to substantiate a claim.

Debits for defective replacement parts will not be accepted and will only be replaced in kind per the manufacturer's standard warranties.

INSTALLATION

CALIFORNIA PROPOSITION 65 WARNING: This product contains chemicals known to the State of California to cause cancer, birth defects or other reproductive harm.

WARNING: This unit contains refractory ceramic fiber (RCF) insulation in the combustion chamber. RCF, as manufactured, does not contain respirable crystalline silica. However, following sustained exposure to very high temperatures (>2192F), the RCF can transform into crystalline silica (cristabolite). The International Agency for Research on Cancer (IARC) has classified the inhalation of crystalline silica (cristabolite) as carcinogenic to humans.

When removing the burners or heat exchangers, take precautions to avoid creating airborne dust and avoid inhaling airborne fibers. When cleaning spills, use wet sweeping or High Efficiency Particulate Air (HEPA) filtered vacuum to minimize airborne dust. Use feasible engineering controls such as local exhaust ventilation or dust collecting systems to minimize airborne dust. Wear appropriate personal protective equipment including gloves, safety glasses with side shields, and appropriate NIOSH certified respiratory protection, to avoid inhalation of airborne dust and airborne fiber particles.

IMPORTANT NOTICE

These instructions are intended only for the use by qualified personnel, specifically trained and experienced in the installation of this type of heating equipment and related system components. Installation and service personnel may be required by some states to be licensed. If your state is such, be sure your contractor bears the appropriate license. Persons not qualified shall not attempt to fix this equipment nor attempt repairs according to these instructions.

WARNING: *Improper installation, adjustment, alteration, service or maintenance may damage the equipment, create a hazard resulting in asphyxiation, explosion or fire, and will void the warranty.*

FLORIDA BUILDING CODE 2010
TIE-DOWN METHOD
ULTIMATE WIND SPEED = 170 MPH, 3 SECOND GUST
NOMINAL WIND SPEED = 132 MPH
EXPOSURE = D

GAS HEATER MODELS 106 & 156

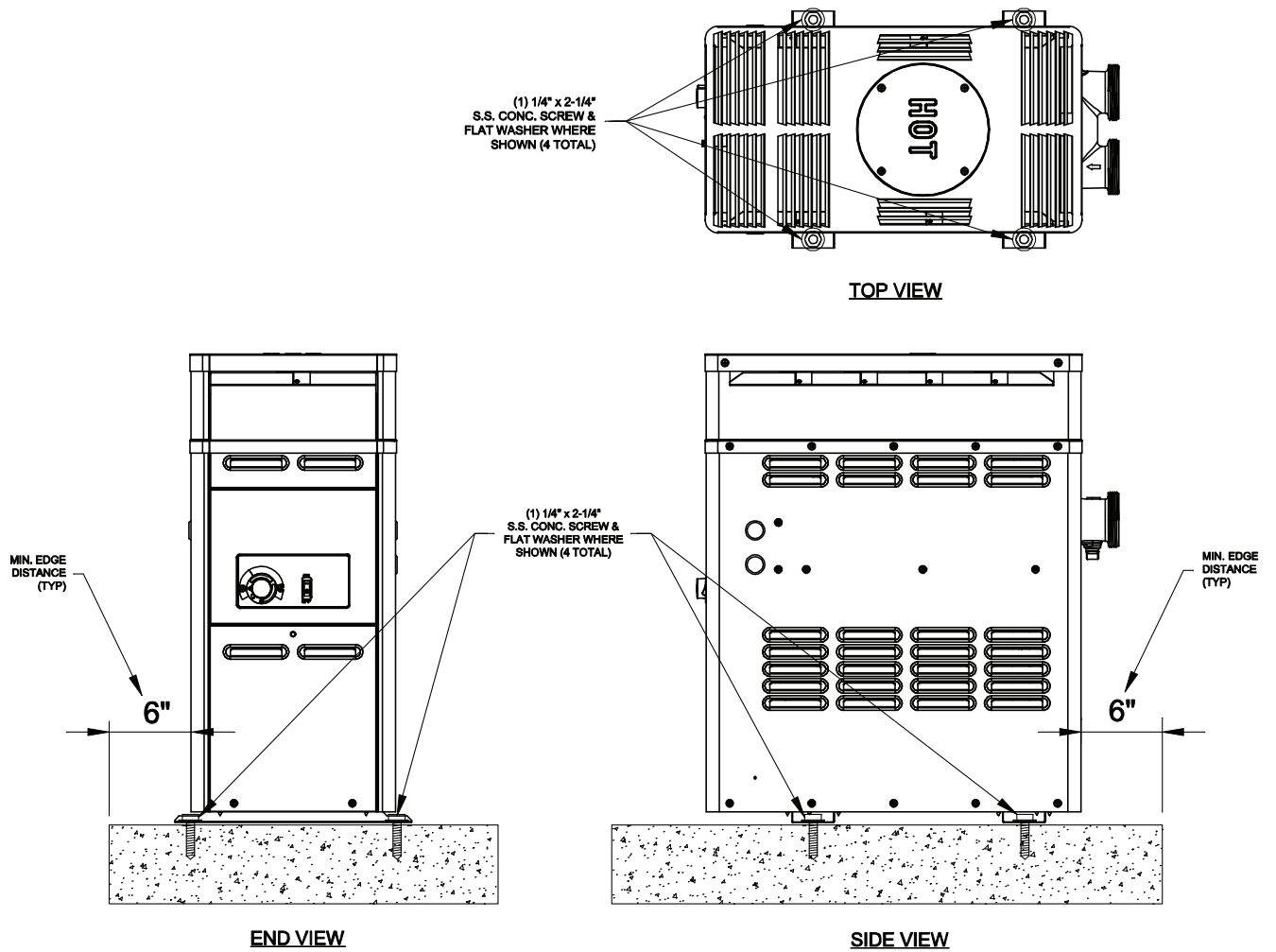

Installation Codes

Installations must be in accordance with local, state, provincial, and national codes, laws, regulations and ordinances. In the absence of local codes, installations must be in accordance with the latest editions of the:

- National Fuel Gas Code, ANSI Z223.1/NFPA 54
- National Electrical Code, ANSI/NFPA 70
- For Canada only: CAN/CSA-B149 Installation Code (B149) and CSA C22.1 C.E.C. Part 1 and Part 2

AVERTISSEMENT: Cet appareil doit être installé conformément au National Fuel gas Code ANSI Z223.1, et aux exigences de l'autorité compétente.

NOTE: The heater should not be located in an area where possible water leakage will result in damage to the area adjacent to the heater or to the structure. When such locations cannot be avoided, it is recommended that a suitable drain pan, with adequate drainage, be installed under the heater. The pan must not restrict combustion air flow.

Clearances

The required minimum clearances from combustible surfaces are shown in Table C below.

Heater Side	Outdoor Installations	Indoor Installations
Top*	Unobstructed	30 in. (76.2 cm)
Front	24 in. (61 cm)	Alcove
Vent	N/A	6 in. (15.2 cm)
Back	12 in. (30.5 cm)	12 in. (30.5 cm)
Right Side	6 in. (15.2 cm)	6 in. (15.2 cm)
Left Side	6 in. (15.2 cm)	6 in. (15.2 cm)

*Clearance from top of vent terminal.

Table C: Required Minimum Clearances from Combustible Surfaces.

Dégagements minimaux à assurer entre les parois de l'appareil et les constructions combustibles: 6po (côtés), 12po (arrière) et 30po (dessus).

When installed according to the listed minimum clearances from combustible construction, the pool heater can be serviced without removing permanent construction around the heater.

However for ease of servicing, we recommend a clearance of at least 18" (45.7cm) on the rear. This will enable the heater to be serviced in its installed location, that is, without movement or removal of the heater.

Minimum clearance from drafthood to combustible construction 6 inches from the vent.

Dégagement minimal de 6 po requis entre le coupe-tirage et une construction combustible. 2 po du conduit de raccordement.

Clearances less than recommended may require removal of the heater to service either the heat exchanger or the burner tray. In either case, the heater must be installed in a manner that will enable the heater to be serviced without removing any structure around the heater.

FLOORING: This heater can be installed on combustible flooring.

Base Installation

Heater must be mounted on a level base, such as cementable slab or cement blocks. Heaters may not be installed on carpeting.

This heater must be installed at least 5ft (1.52m) from the inside wall of a pool unless separated from the pool by a solid fence, wall or other permanent solid barrier.

Ce chauffe-piscine doit être installé à au moins 5 peds (1.52m) de la paroi interne de la piscine à moins d'être isolé de la piscine par un clôture, un mur ou autre barrière permanente.

Outdoor Installation

WARNING: The heater should not be located in an area where water sprinklers or other devices may cause water to spray through the cabinet louvers and into the heater. This could cause internal rusting or damage electrical components, and will not be covered under warranty.

WARNING: Do not install within 3 feet (0.9m) of a heat pump or an outdoor condensing unit. Strong air intake from this type of equipment can disturb the combustion process and cause damage or personal injury.

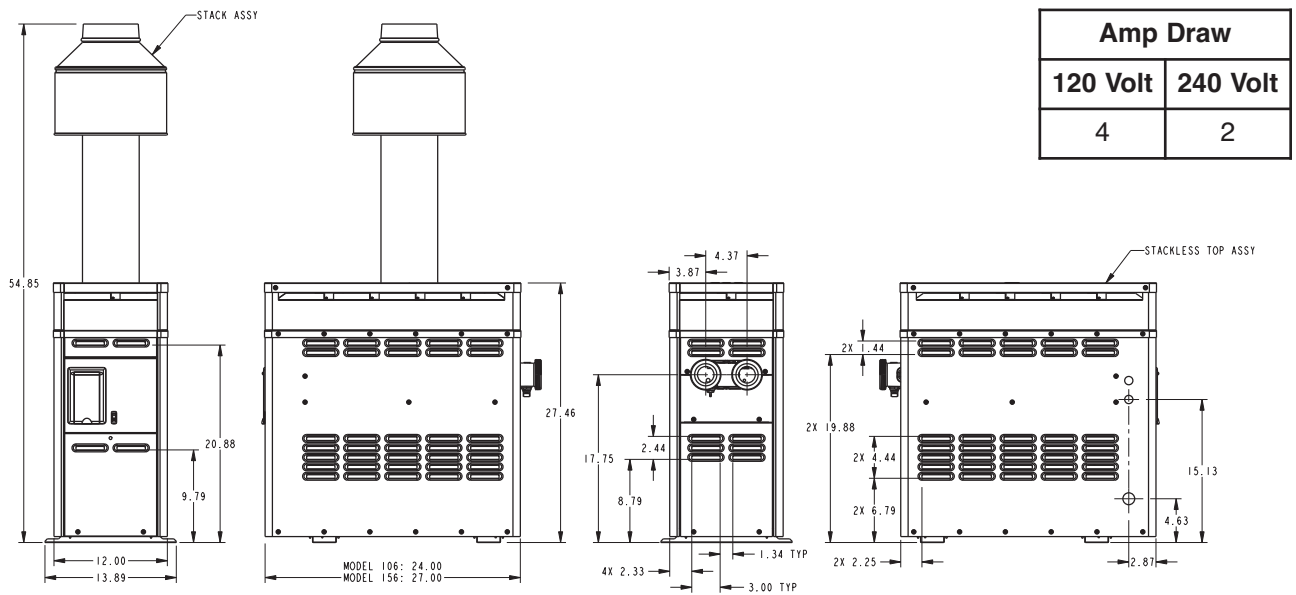

Fig. 3: Overall Dimensions

NOTE: This heater is design-certified for outdoor installation when equipped with the approved top(s) for outdoor use.

Heater with Outdoor Stackless Top

Heaters must not be installed under an overhang of less than 3 ft (0.9m) from the top of the heater. Three sides must be open in the area under the overhang. Roof water drainage must be diverted away from heaters installed under overhangs with the use of gutters.

Ne pas installer ce chauffe-piscine sous une saillie mesurant moins de 3 pi de hauteur. La partie sous la saillie doit être ouverte sur 3 côtés.

- For U.S. installations, the point from where the flue products exit the heater must be a minimum of 4 ft (1.2m) below, 4 ft (1.2m) horizontally from, or 1 ft (0.3m) above any door, window or gravity inlet into any building. The top surface of the heater shall be at least 3 ft (0.9m) above any forced air inlet, or intake ducts located within 10 ft (3m) horizontally. See Fig. 5.
- For installations in Canada, pool heaters shall not be installed with the top of the vent assembly within 10 ft (3m) below, or to either side, of any opening into the building. Refer to the latest revisions of CAN/CSA-B149. The heater must be raised 7 in (0.2m) above the surface which could support snow, ice or debris. Refer to the latest revisions of CAN1-2.21-M85.

Outdoor Stack

NOTE: The outdoor stack is optional equipment and does not come standard with the heater. Use part number 014718 for the 106 and 014719 for the 156.

High Wind Conditions (Outdoor Units Only)

In areas where high winds are frequent, it may be necessary to locate the heater a minimum of 3 ft (0.9m) from high vertical walls, or install a wind-break so the heater is not in direct wind current.

In areas of daily high winds, it may be necessary to replace the outdoor stackless top with a stack adapter in combination with a wind-resistant/weather-proof outdoor stack. See Fig. 4.

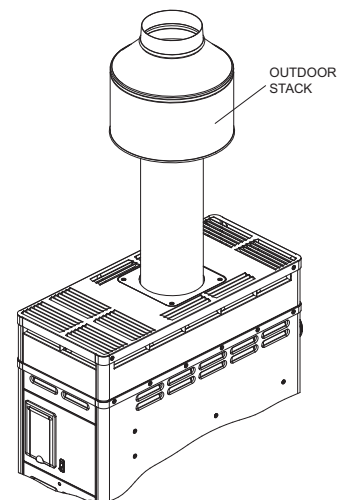

Fig. 4: Outdoor Stack

The outdoor stack serves the same function as the low profile stackless top and should be installed in accordance with the same clearance requirements. Follow the installation instructions provided with the Outdoor Stack Kit for installation.

CAUTION: Combustion air must not be contaminated by corrosive chemical fumes which can damage the heater and void the warranty. Do not store chlorine, bromine, baquasil or acid in the same room as the heater.

Indoor Installation

The heater is design-certified for indoor installation when equipped with the approved draffhood.

NOTE: For Canada, indoor installation is restricted to an enclosure that is not occupied and does not directly communicate with an occupied area. Refer to the latest edition of CAN/CSA-B149 for specific requirements.

WARNING: Indoor heaters require a draffhood that must be connected to a vent ppe and properly vented to the outside. Failure to follow this procedure can cause fire or fatal carbon monoxide poisoning.

Locate heater as close as is practical to a chimney or gas vent. Heater must always be vented to the outside. See Vent Piping section for details. Minimum allowable space is shown on the rating plate. Follow the installation instructions provided with the Indoor Draffhood Kit for installation.

This draffhood must be installed without alteration. see rating plate.

Ce coupe-tirage doit être installé sans modification. Voir la plaque signalétique.

Combustion & Ventilation Air (Indoor Units Only)

The heater must have both combustion and ventilation air. Minimum requirements for net free air supply openings are one opening that is 12 inches (30.5 cm) from the ceiling for ventilation, and one opening that is 12 inches (30.5 cm) from the floor for combustion air as outlined in the latest edition of the National Fuel Gas Code, ANSI Z223.1 (Canada-CAN/CSA-B149) and any local codes that may have jurisdiction.

- All Air from inside the building each opening shall have a minimum net free area as noted in Table E.

Model	Area
106	105 in ² (677 cm ²)
156	150 in ² (968 cm ²)

Table E: Minimum Air Area

- All air from outdoors when air is supplied directly from outside the building each opening shall have a minimum net free area as noted in Table D.

Vent Piping

Vent piping the same size as the draffhood outlet is recommended, however, when the total vent height is at least 10 ft (3m) (draffhood relief opening to vent terminal), the vent pipe size may be reduced as specified in the National Fuel Gas Code, ANSI Z223.1 (Canada - CAN/CSA-B149). As much as possible, avoid long horizontal runs of vent pipe and too many elbows.

If installation requires horizontal runs, the vent pipe must have a minimum of 1/4 in. (2cm per m) per ft rise and should be supported at not more than five foot intervals. Plumbers tape, criss-crossed, will serve to space both horizontal and vertical piping. Gas vents supported only by the flashing and extending above the roof more than 5 ft (1.5m) should be securely guyed or braced to withstand snow and wind loads. We recommend use of insulated vent pipe spacers through the roof and walls.

For protection against rain or blockage by snow, the vent pipe must terminate with a vent cap which complies with local codes or, in the absence of such codes, the latest edition of the National Fuel Gas Code, ANSI Z223.1 (Canada - CAN/CSA-B149).

Model	Unrestricted opening	Typical screened or louvered opening	Typical screened and louvered opening
106	27 in ² (174 cm ²)	41 in ² (265 cm ²)	54 in ² (348 cm ²)
156	38 in ² (245 cm ²)	57 in ² (368 cm ²)	76 in ² (490 cm ²)

Table D: Minimum Air Net Area

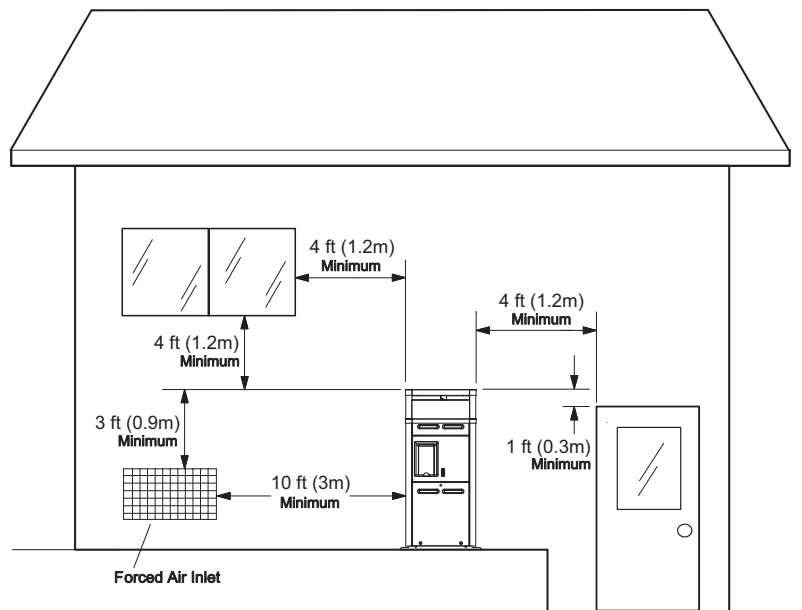

Fig. 5: Outdoor Installation Clearances

The discharge opening must be a minimum of 2 ft (0.6m) vertically from the roof surface and at least 2 ft (0.6m) higher than any part of the building within 10 ft. (3m) vent stack shall be at least 5 ft (1.5m) in vertical height above the draffhood outlet. The vent cap location shall have a minimum clearance of 4 ft (1.2m) horizontally from, and in no case below, unless a 4 ft (1.2m) horizontal distance is maintained, from electric meters, gas meters, regulators and relief equipment.

The weight of the vent stack or chimney must not rest on heater draffhood. Support must be provided in compliance with applicable codes. The heater top and draffhood must be readily removable for maintenance and inspection. Vent pipe should be adequately supported to maintain proper clearances from combustible construction.

Type "B" double-wall or equivalent vent pipe is recommended. However single-wall metal vent pipe may be used as specified in the latest edition of the National Flue Gas Code ANSI Z223.1 (Canada - CAN/CSA-B149).

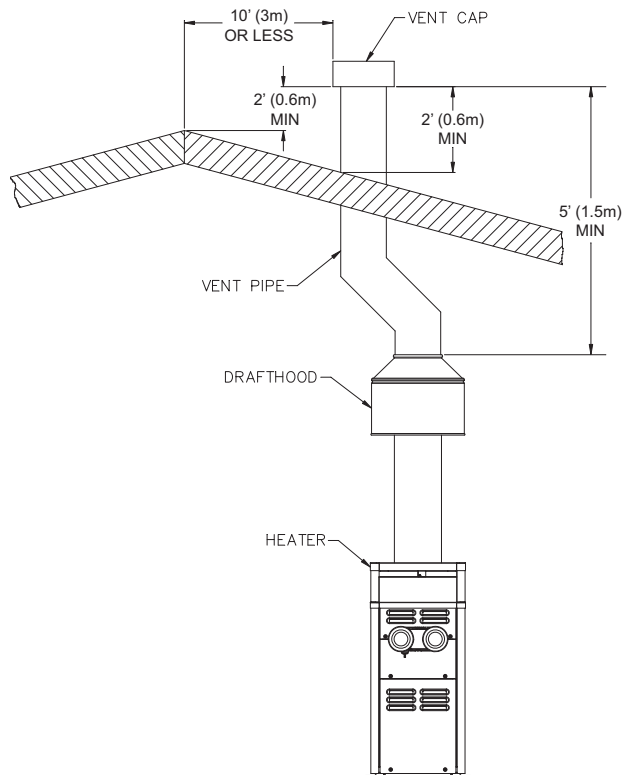

Fig. 6: Vent Piping Requirements

Gas Connections

Gas piping must have a sediment trap ahead of the heater gas controls, and a manual shut-off valve located outside the heater jacket. Use the pipe finish flange to seal between the gas line and the heater jacket (see Fig. 7). All gas piping should be tested after installation in accordance with local codes.

CAUTION: Do not use 5, 10 or 20 gallon (19.38 or 76 Liter) propane tanks, like those used with consumer barbecues, to supply gas to this heater.

CAUTION: The heater and its manual shut-off valve must be disconnected from the gas supply during any pressure testing of that system at test pressures in excess of 1/2 psig (3.5 kPa). The heater and its gas connections shall be leak tested before placing the appliance in operation. Use soapy water for leak test. do not use open flame.

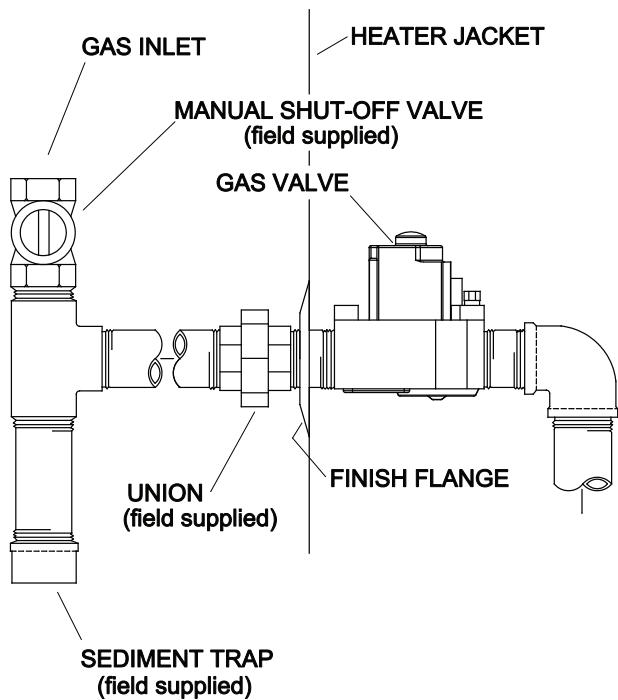

Fig. 7: Gas Line Sediment Trap

NOTE: Do not use Teflon tape on gas line pipe thread. A flexible pipe sealant suitable for LP gases is recommended.

Gas Pressure Regulator

The gas pressure regulator is preset at 4.0 in W.C. (1.0kPa) for natural gas and 10.0 in W.C. (2.5kPa) for propane gas.

If adjustment is needed, remove plug and turn adjustment screw clockwise to increase pressure or counter-clockwise to decrease pressure.

Gas Pressure*	Natural Gas	Propane Gas
Max. Inlet (static)	10.5 in. WC (2.6 kPa)	13 in. WC (3.2 kPa)
Min. Inlet (dynamic)	5 in. WC (1.2 kPa)	11 in. WC (2.7 kPa)
Manifold Gas (dynamic)	4 in. WC (1.0 kPa)	10 in. WC (2.5 kPa)

*Static means without heater operating, dynamic refers to heater operating.

Table F: Gas Pressure

Gas Pressure Adjustment Locations

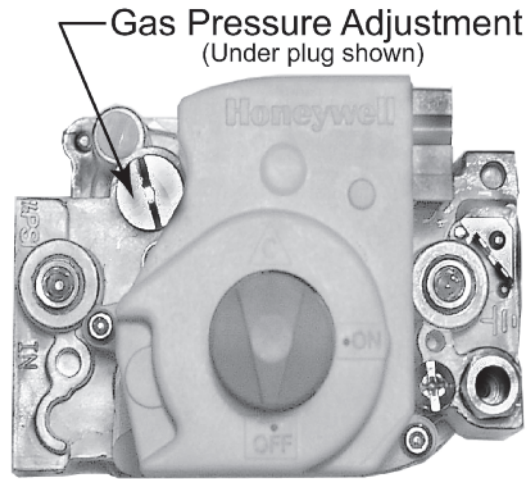

Fig. 8: Honeywell Gas Valve

Electronic Ignition Gas Valves

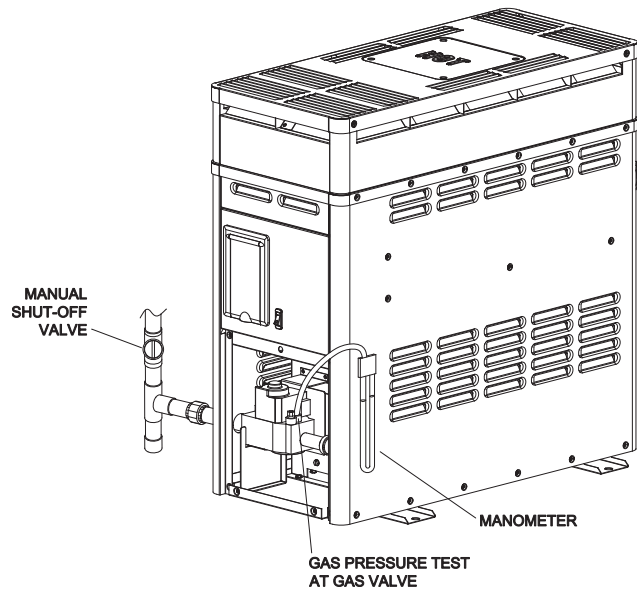

Fig. 9: Location of Gas Pressure Adjustment

Pipe Sizing for Gas Connections

Model	Tubing	Input	1/2 in. (1.27cm)		3/4 in. (1.91cm)		1 in. (2.54cm)	
			NAT	LPG	NAT	LPG	NAT	LPG
106	Cu	105,000 BTU/hr (30.8 kW)	26 ft (8 m)	65 ft (20 m)	99 ft (30 m)	252 ft (77 m)	350 ft (107 m)	892 ft (272 m)
156	Cu	150,000 BTU/hr (43.9 kW)	13 ft (4 m)	34 ft (10 m)	51 ft (16 m)	130 ft (40 m)	180 ft (55 m)	459 ft (140 m)

* Natural Gas 1000 BTU/FT³ 0.60 Specific Gravity @ 0.5 in WC Pressure Drop
(Gaz Naturel 3154.5 W/m³ 0.60 Densité @ 0.124 kPa Pressure Drop)

* Propane Gas 2500 BTU/FT³ 1.53 Specific Gravity @ 0.5 in WC Pressure Drop
(Le Gaz Propane 7886.3 W/m³ 1.53 Densité @ 0.124 kPa Pressure Drop)

Table G: Maximum Equivalent Pipe Length

Water Connections

The heater requires water flow and positive pressure to fire and operate properly. It must therefore be installed downstream of the discharge side of the filter pump. A typical installation is plumbed as follows:

1. The inlet side of the filter is plumbed directly to the discharge side of the filter pump;
2. The outlet side of the filter is then plumbed to the inlet of the heater; and
3. The outlet of the heater is plumbed to the return line to the pool or spa. The pump, filter and heater are thus plumbed in series.

Plumbing from the heater back to the pool or spa must not have any valves or restriction that could prevent flow when the pump is operating.

Heater must be located so that any water leaks will not damage the structure of adjacent area. PVC pipe may be glued directly into supplied CPVC header unions.

Flow Rates

Model No.	Minimum	Maximum
106/156	20 GPM (75 L)	70 GPM (265 L)

*When flow rates exceed maximum 70 GPM, an external auxiliary bypass valve is required. See External Auxiliary Bypass Valve section for details.

Table H: Water Flow Rates

Polymer Headers

Before attaching the supplied 2-inch (5 cm) CPVC unions to the In/Out header, make sure the O-rings are properly seated in the grooves. Use AquaLube or equivalent non-petroleum-based lubricant on the O-ring. Hand tighten the unions. Glue PVC or CPVC piping directly to the unions.

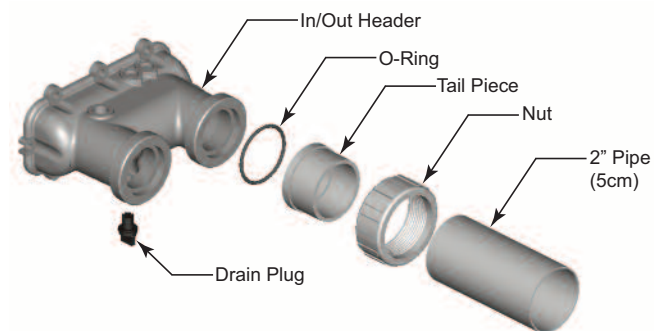

Fig. 10: In/Out Header for 2" Installation

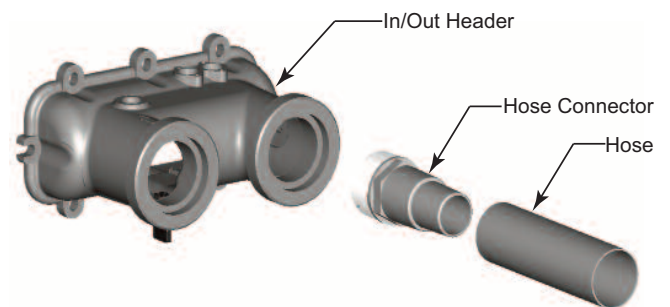

Fig. 11: Optional In/Out Header for 1-1/2" (3.8 cm) or 1-1/4" (3.2 cm) Hose Connection

If there is any possibility of back-siphoning when the pump stops, it is recommended that a check valve (or valves) also be installed in the system.

Internal Automatic Bypass Valve

A built-in automatic bypass valve is provided in the In/Out header. The internal bypass valve automatically responds to changes in water pressure in the piping system. The proper amount of water flow is maintained through the heater under varying pressures dictated by the conditions of the pump and filter.

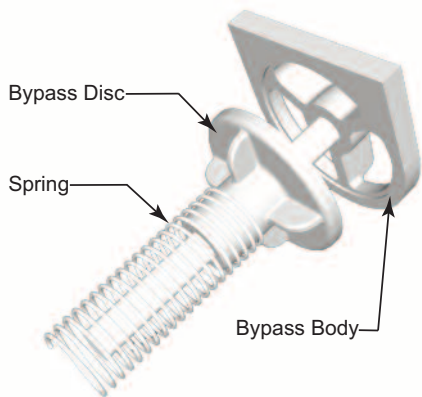

Fig. 12: Internal Automatic Bypass Valve
External Auxiliary Bypass Valve

An auxiliary bypass valve must be used when flow rates exceed 70 GPM (265 LPM). Usually a high-performance pump size larger than one horsepower will exceed this flow rate. This valve is required to complement the function of the automatic bypass valve, particularly when starting the heater in winter or early spring when the spa or pool temperature is below 50°F (10°C). It also serves to eliminate needless pressure drop through the heater and accompanying reduction in the flow rate to the spa jets, etc.

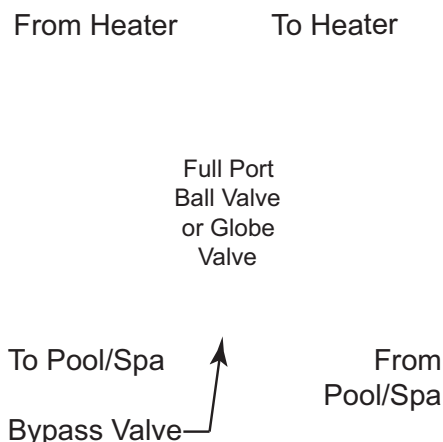

Fig. 13: Auxiliary Bypass Valve

NOTE: Do not use a gate valve as an auxiliary bypass valve.

Auxiliary Bypass Valve Adjustment

To set bypass: With clean filter, adjustment is made by feeling the inlet and outlet pipes at the heater. Outlet pipes should be slightly warmer than inlet and comfortable to the touch. If pipe is hot, close bypass; if cold, open bypass.

Pressure Relief Valve Installation

To conform to local building codes, it may be necessary to install a pressure relief valve. A 3/4" (1.9 cm) pressure relief valve, having a capacity equal to or greater than the BTUH input of the heater to be installed, is recommended for this heater. The maximum pressure relief valve setting is 125 psi (862 kPa). This relief valve needs to be installed on the outlet pipe from the header as noted in Fig. 14 below.

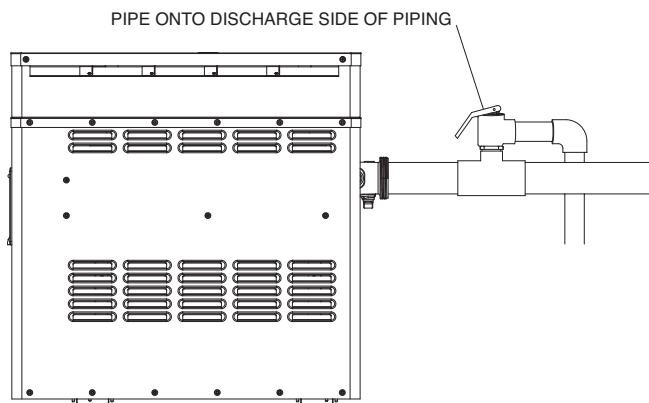

Fig. 14: Pressure Relief Valve Installed

If required, this needs to be installed in a field-supplied fitting external to the heater. The valve shall be installed in a vertical position. Do not over-tighten. Install the pressure relief valve hand tight plus 1/2 turn.

WARNING: To avoid water damage or scalding due to relief valve operation, drain pipe must be connected to valve outlet and run to a safe place of discharge. Drain pipe must be the same size as the valve discharge connection throughout its entire length and must pitch downward from the valve. No shut-off valve shall be installed between the relief valve and the drain line.

The valve lever should be tripped at least once a year to ensure that waterways are clear. If the relief valve does not function properly, replace it immediately.

Heat Exchanger Pressure Drop Table

Flow (GPM)	Pressure Drop (ft of Head)
20	7.6
30	8.2
40	8.7
50	9.3
60	9.8
70	10.4

Table I: Pressure Drop

Electrical Connections

Be sure that electrical service to the heater has proper overload fuse or circuit breaker protection, wire size and connections which comply with all applicable codes.

If any of the original wire as supplied with the appliance must be replaced, it must be replaced with type 302°F (150°C) wire or its equivalent.

Si un des fils original fourni avec l'appareil doit être remplacé, utilisez un fil 302°F (150°C), ou l'équivalent.

The heater comes standard with a 120 VAC 3-prong power cord. For 240 VAC applications, see figure 16. Power source must be a wired ground, with ground fault circuit interruption circuitry.

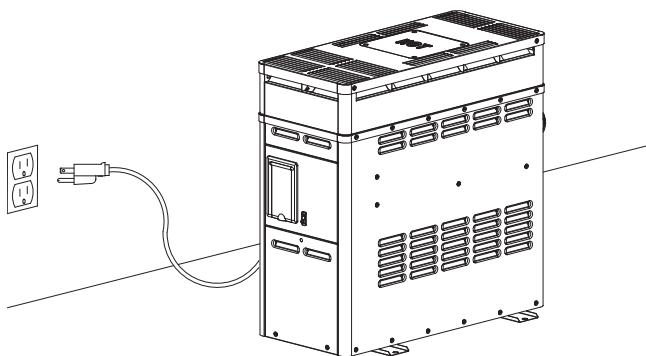

Fig. 15: Electronic Heater Power

ATTENTION. Au moment de l'entretien des commandes, étiquetez tous les fils avant de les débrancher. Des erreurs de câblage peuvent entraîner un fonctionnement inadéquat et dangereux.

The heater must be electrically grounded and bonded in accordance with local codes, or, in the absence of local codes, with the latest edition of the National Electrical Code, ANSI/NFPA 70. (Canada - Canadian Electrical Code, CSA C22.1, Part 1 and Part 2.)

NOTE: Input power to the heater (120 VAC) can be supplied from the load (pump) side of time clock or directly from the GFCI power source. It is preferred to make connection to the load/pump side of the time clock.

WARNING: Risk of electrical shock. More than one disconnect switch may be required to de-energize the equipment before servicing.

CAUTION: Label all wires prior to disconnection when servicing controls. wiring errors can cause improper and dangerous operation.

Installation Instructions—240 Volt

CAUTION: This heater has provisions to be connected to an alternate supply source. To reduce the risk of electric shock, disconnect all connections before servicing.

1. Disconnect the 120V power cord from power source.
2. Remove knurled screw from the lower front panel.
3. Remove the front panel and set aside.
4. Remove the two stainless screws holding the control panel in place.
5. Lower the control panel and then sway it forward. The 120V wiring should be visible next to the transformer.
6. Disconnect and remove the 120V power cord from the heater.
7. Bring the 240V supply line into the control box.
8. Install a wire nut on the white transformer wire. (See Fig 16)
9. Wire nut the 240V supply lines to the red and black wires on the transformer. (See Fig 16)

240V HOOK-UP

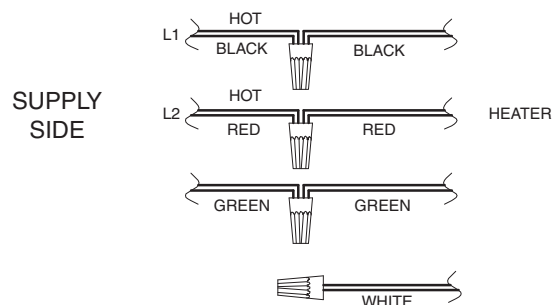

Fig. 16: 240V Hook-Up

10. Wire nut the supply ground line to the green transformer wire. (See Fig 16)
11. Reposition the control panel back in place and re-install the two screws.
12. Re-install front panel and knurled screw.

OWNER'S OPERATING INSTRUCTIONS

Control Adjustments—Analog

The pool or spa water temperature is controlled by the thermostat on the upper front panel of the heater. The control center contains an On/Off toggle switch and a thermostat. The switch functions as a means for turning the heater On or Off.

The thermostat is fitted with a means of limiting the upper temperature limit below the maximum level. The knob stop adjustment ring shown in Fig. 17 is adjustable by loosening the set screw, rotating the knobstop ring to the desired location, and retightening the set screw.

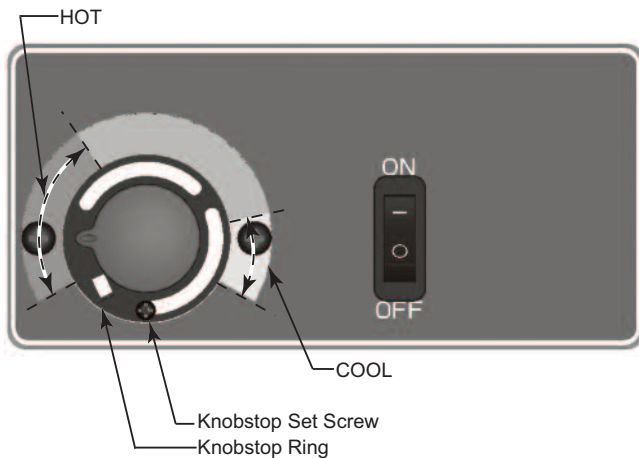

Fig. 17: Water Temperature Thermostat

NOTE: Maximum temperature is 104°F (40°C).

Control Adjustments—Digital

The pool heater (chauffe-piscine) touchpad, located on the upper front panel of the heater, allows the user to select either POOL or SPA operation, and to adjust the setpoint temperature. The LCD display window indicates the mode (OFF, SPA, POOL) and the actual water temperature. A manual power switch provided below the touchpad turns the control power ON or OFF.

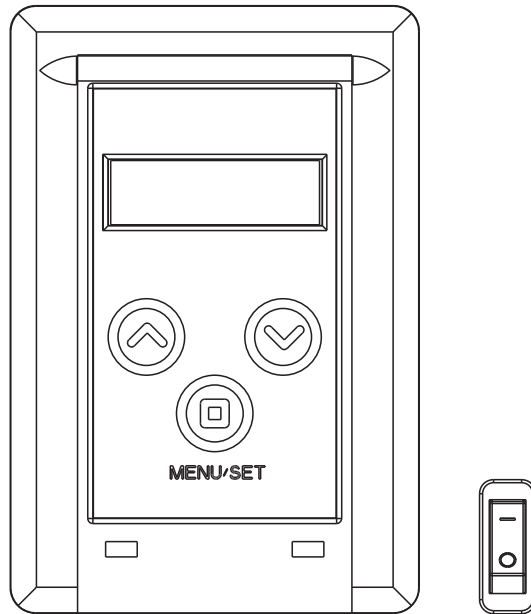

Fig. 18: Digital Control Adjustment

MENU/SET Button

The MENU/SET button is used to select either POOL or SPA operation. It also allows the user to turn the heater off electronically. The LCD remains energized and displays OFF, while also continuing to show the actual water temperature.

Temp Buttons

If the heater is in POOL or SPA mode, the desired water temperature (SETPOINT) will also be displayed and may be adjusted using the UP or DOWN buttons.

Operation

In the POOL or SPA modes, the actual water temperature is displayed along with the desired water temperature (SETPOINT). When the water temperature is above the setpoint, "Water Temp" will alternate with "No Demand." When the water temperature is below the setpoint and the heater is firing, "Water Temp" will alternate with "Heating."

To adjust the setpoint temperature, make sure the control is in the appropriate mode (POOL or SPA) and push the UP or DOWN buttons.

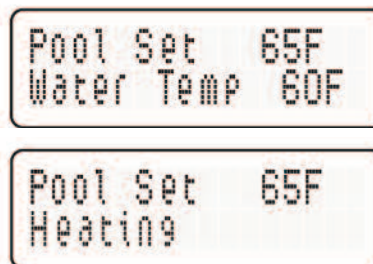

ALTERNATING DISPLAYS DURING HEATING



FOR YOUR SAFETY READ BEFORE OPERATING POUR VOTRE SÉCURITÉ LISEZ AVANT DE METTRE EN MARCHÉ

WARNING: If you do not follow these instructions exactly, a fire or explosion may result causing property damage, personal injury or loss of life.



AVERTISSEMENT: Quiconque ne respecte pas à la lettre les instructions dans la présente notice risque de déclencher un incendie ou une explosion entraînant des dommages, des blessures ou la mort.

- A. This appliance is equipped with an ignition device which automatically lights the pilot. Do NOT try to light the pilot by hand.
- B. BEFORE OPERATING smell all around the appliance area for gas. Be sure to smell next to the floor because some gas is heavier than air and will settle on the floor.
- WHAT TO DO IF YOU SMELL GAS
- * Do not try to light any appliance.
 - * Do not touch any electric switch; do not use any phone in your building.
 - * Immediately call your gas supplier from a neighbor's phone. Follow the gas supplier's instructions.
 - * If you cannot reach your gas supplier, call the fire department.
- C. Use only your hand to push in or turn the gas control knob. Never use tools. If the knob will not push in or turn by hand, do not try to repair it, call a qualified service technician. Force or attempted repair may result in a fire or explosion.
- D. Do not use this appliance if any part has been under water. Immediately call a qualified service technician to inspect the appliance and to replace any part of the control system and any gas control which has been under water.
- A. Cet appareil est muni d'un dispositif d'allumage qui allume automatiquement la veilleuse. Ne tentez pas d'allumer la veilleuse manuellement.
- B. AVANT DE FAIRE FONCTIONNER, renifllez tout autour de l'appareil pour détecter une odeur de gaz. Renifllez près du plancher, car certains gaz sont plus lourds que l'air et peuvent s'accumuler au niveau du sol.
- QUE FAIRE SI VOUS SENTEZ UNE ODEUR DE GAZ:
- * Ne pas tenter d'allumer d'appareil.
 - * Ne touchez à aucun interrupteur; ne pas vous servir des téléphones se trouvant dans le bâtiment.
 - * Appelez immédiatement votre fournisseur de gaz depuis un voisin. Suivez les instructions du fournisseur.
 - * Si vous ne pouvez rejoindre le fournisseur, appelez le service des incendies.
- C. Ne poussez ou tournez la manette d'admission du gaz qu'à la main; ne jamais utiliser d'outil. Si la manette reste coincée, ne tentez pas de la réparer; appelez un technicien qualifié. Le fait de forcer la manette ou de la réparer peut déclencher une explosion ou un incendie.
- D. N'utilisez pas cet appareil s'il a été plongé dans l'eau, même partiellement. Faites inspecter l'appareil par un technicien qualifié et remplacez toute partie du système de contrôle et toute commande qui ont été plongés dans l'eau.

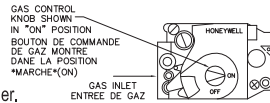

OPERATING INSTRUCTIONS INSTRUCTIONS DE MISE EN MARCHÉ

1. **STOP!** Read the safety information above on this label.
2. Set the thermostat to the lowest setting.
3. Turn off all electric power to the appliance.
4. This appliance is equipped with an ignition device which automatically lights the pilot. Do NOT try to light the pilot by hand.
5. Turn gas control knob clockwise  to "OFF".
6. Wait five (5) minutes to clear out any gas. Then smell for gas, including near the floor. If you smell gas STOP! Follow "B" in the safety information above on this label. If you don't smell gas, go to the next step.
7. Turn gas control knob counter clockwise  to "ON".
8. Turn on all electric power to the appliance.
9. Set thermostat to desired setting.
10. If the appliance will not operate, follow the instructions "To Turn Off Gas To Appliance" and call your service technician or gas supplier.



1. **ARRÊTEZ!** Lisez les instructions de sécurité sur la portion supérieure de cette étiquette.
2. Réglez le thermostat à la température la plus basse.
3. Coupez l'alimentation électrique de l'appareil.
4. Cet appareil est muni d'un dispositif d'allumage qui allume automatiquement la veilleuse. Ne tentez pas d'allumer la veilleuse manuellement.
5. Tournez le bouton de la vanne de gaz dans le sens horaire  à la position "Arrêt" (OFF).
6. Attendez cinq (5) minutes pour laisser échapper tout le gaz. Renifllez tout autour de l'appareil, y compris près du plancher, pour détecter une odeur de gaz. Si vous sentez une odeur de gaz, ARRÊTEZ! Passez à l'étape B des instructions de sécurité sur la portion supérieure de cette étiquette. S'il n'y a pas d'odeur de gaz, passez à l'étape suivante.
7. Tourner le bouton de commande de gaz dans le sens antihoraire  à la position "Marche" (ON).
8. Mettez l'appareil sous tension.
9. Réglez le thermostat à la température désirée.
10. Si l'appareil ne se met pas en marche, suivez les instructions intitulées "Comment couper l'admission de gaz de l'appareil" et appelez un technicien qualifié ou le fournisseur de gaz.

TO TURN OFF GAS TO APPLIANCE COMMENT COUPER L'ADMISSION DE GAZ L'APPAREIL

1. Set the thermostat to the lowest setting.
2. Turn off all electrical power to the appliance if service is to be performed.
3. Turn gas control knob clockwise  to "OFF".
1. Réglez le thermostat à la température la plus basse.
2. Coupez l'alimentation électrique de l'appareil s'il faut procéder à l'entretien.
3. Tournez le bouton de commande de gaz dans le sens horaire à la  position "Arrêt" (OFF).

Thermostat Operation— Advanced Flame Technology (AFT) Board

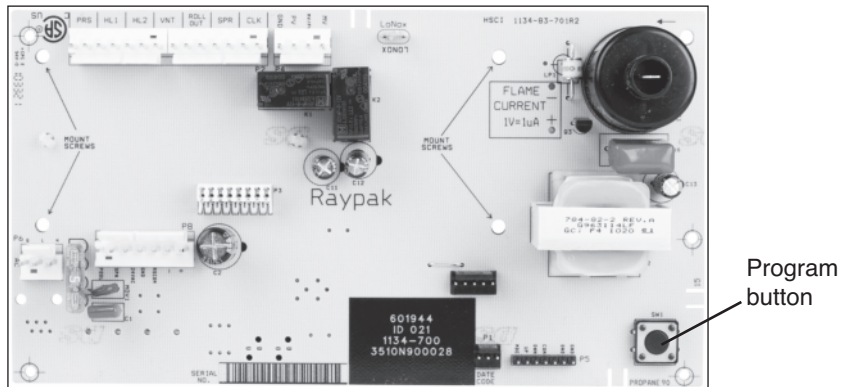

Service Menu and Fault History

To access the Service Menu and fault history, press the MENU/SET and UP buttons simultaneously for 3 to 5 seconds. The heater will continue to operate normally while in the Service Menu. The first screen displayed is the Flame Strength indicator, which indicates the pilot flame current using a bar graph and numerical display. A signal of less than 4 indicates a weak flame signal and may require service. Refer to Section 5 – Troubleshooting for possible causes and corrections.



FLAME STRENGTH INDICATOR

Press the DOWN button. The Supply Voltage screen indicates the voltage supplied to the control board. Normal readings range from 24 to 29 volts.

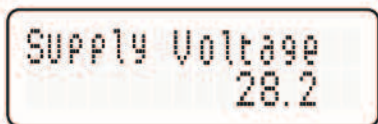

SUPPLY VOLTAGE INDICATOR

Press the DOWN button. The Run Time indicates the total hours of operation for the pool heater, as measured by the amount of time that the main gas valve has been powered. The Cycle count indicates the number of on/off cycles of the heater, as measured by the number of times the pilot valve has been powered.

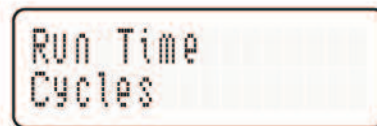

RUN TIME INDICATOR





Press the DOWN button. The Fault History can display up to ten faults in memory. The order of the faults begins with "Fault Last," which is the most recent fault, and proceeds through ten most recent messages in chronological order. The second line of the display shows the fault message. If there are no faults in the history buffer, the second line reads "All Faults Clear."

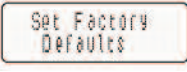
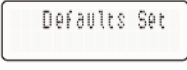
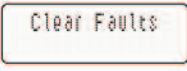

FAULT HISTORY

Program Button

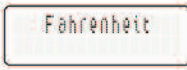
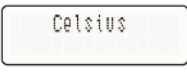
- 1) Remove the two screws holding the control cover, and swing the panel down so the back side of the board is visible (see page 19). Locate the Program Mode button (marked as SW1) as shown on page 19. Press and hold the button (5-7 seconds) until **Set Factory Defaults** appears on the display. Release the program button.
- 2) Press the **MENU/SET** button sequentially until the desired program event is reached. There are 5 different events that can be programmed. They appear in the sequence listed below:

	Resets board to factory default settings.
	
	
	Resets faults in the History File.
	
	Change from Fahrenheit to Celsius.
	SPA setpoint maximum adjustment.
	POOL setpoint maximum adjustment.

Set Factory Defaults

Refer to step one above to access the program screen. **Set Factory Defaults** should appear on the screen. If it does not, press the **MENU/SET** button until **Set Factory Defaults** appears on the digital display. Press and hold both UP and DOWN buttons for 5-7 seconds until **Defaults Set** appears. This operation resets the operating program to its factory default values. Both the POOL and SPA setpoints will revert to 65°F (18.5°C) and both POOL and SPA maximum temperature settings will be 104°F (40.0°C). The Control Lockout PIN will be cleared and the control will resume normal operation.

Clear Faults

Refer to step one above to access the program screen. Press the **MENU/SET** button until **Clear Faults** appears on the digital display. Press and hold both UP and DOWN buttons for 5-7 seconds until **Faults Cleared** appears. This operation resets the Fault History file to "0" and clears all the stored faults.

Fahrenheit or Celsius

Refer to step one above to access the program screen. Press the **MENU/SET** button until **Fahrenheit** or **Celsius** appears on the digital display. The digital display is capable of displaying Celsius as well as Fahrenheit temperatures. The UP or DOWN buttons will select **Fahrenheit** or **Celsius** on the temperature display. Choose the desired temperature scale.

Spa Max Temp – Spa Set Point Maximum Adjustment

Refer to step one above to access the program screen. Press the **MENU/SET** button until **Spa Max Temp** appears on the digital display. Using the UP and DOWN buttons will change the Maximum Temperature Setting to your desired value. The control can be set for a maximum of 107°F (41.7°C).

Pool Max Temp – Pool Set Point Maximum Adjustment

Refer to step one above access into the program screen. Press the **MENU/SET** button until **Pool Max Temp** appears on the digital display. Using the UP and DOWN buttons will change the Maximum Temperature Setting to your desired value. The control can be set for a maximum of 107°F (41.7°C).

Control Lockout

The heater is equipped with a Control Lockout feature to prevent unauthorized tampering or adjustment of the control settings. To lock out the controls, press the DOWN button and **MENU/SET** button for 5 seconds. Choose a three digit PIN, using the UP and DOWN buttons to select the digits and the **MENU/SET** button to lock in selections. Confirm your selection and record your PIN.

To unlock the controls, press any button to bring up the **Enter PIN** menu. Enter the PIN that was used to lock the control. Note that power cycling will **not** clear the lockout. Successfully unlocking the control will display "Lockout Cleared." Failure to enter the correct PIN will display "Invalid PIN."

In the event that the user-selected PIN is lost or does not clear the Control Lockout, use the Program Button to **Set Factory Defaults**. This will clear the PIN and allow normal operation and selection of a new PIN if desired. See the **Program Button** directions on this page for details.

NOTE: Both the POOL and SPA setpoints will revert back to 65°F (18.5°C) and the POOL and SPA maximum temperature settings will be 104°F (40.0°C). These setpoints will need to be readjusted to desired settings.

NOTE: The LCD temperature display may not agree with the temperature reading of your pool or spa thermometer. The heater reads the water temperature at the inlet. Due to the circulation characteristics of any pool or spa, the water temperature at the inlet to the heater may differ from that observed at a given location in the pool or spa.

STATUS AND DIAGNOSTICS

The digital thermostat models are programmed to display a variety of status and diagnostic messages, depending on the operating conditions.

The following heat status messages are displayed in Pool, Spa, and Remote modes when there are no active fault conditions.

Display	Condition
Heating	Call for heat established, flame present
Spark	Spark operating
No Demand	Heat demand is satisfied

The following conditions are displayed in Pool, Spa and Remote modes.

Display	Condition
Sensor Failure	Thermistor temperatures disagree by more than 2°F (1.1°C)
Sensor Open	Thermistor sensor failed open. (Below -20°F (-29°C))
Sensor Short	Thermistor sensor failed short. (Above 217°F (103°C))
Flame w/o CFH	Board is sensing flame when both main and pilot valves are commanded shut.
PV Output Fault	Pilot gas valve output is not in commanded state.
MV Output Fault	Main gas valve output is not in commanded state.
Internal Fault	Board fault, replace board.
EEPROM Fault	Memory fault, reset set points, replace board if fault does not clear.
Clock/Fireman Sw	Time clock/fireman switch circuit is open.
Low Temp Lockout	Water temperature below 36°F (2°C).

The following conditions are displayed only while there is a demand for heat present.

Display	Condition
Water Sw Open	Water pressure switch open.
Vent/Field Sw #1	Vent spill switch/field switch #1 open.
Hi Limit 1 Fault	High limit 1 open.
Hi Limit 2 Fault	High limit 2 open.
Rollout Sw Open	Rollout switch open.
Flow/Field SW #2	Field-supplied flow switch/field switch #2 open.
Ignition Lockout (Propane Tab Broken)	Alternating with “No pilot sensed” - Pilot flame not established within the required time (15 sec or 90 sec). Alternating with “Main Ign Failure” - Pilot flame lost during the 8 second trial to ignite the main burner.
Ignition Failure (Propane Tab Not Broken)	Alternating with “No pilot sensed” - Pilot flame not established within 90 seconds.
Ign 6min Delay (Propane Tab Not Broken)	Alternating with “Main Ign Failure” - Pilot flame lost 4 times within the 8 second trial to ignite the main burner. Heater will lockout for 6 minutes before retrying.

REMOTE CONTROL INSTALLATION AND OPERATION

CAUTION: Before installing remote controls to the AFT thermostat model heaters, read the following: The digital thermostat model is remote-ready in most cases. The digital liquid crystal display (LCD) shows the actual pool temperature, operating status, and service codes (See examples below). The touch pad on the control panel allows you to select the desired pool or spa temperature. It also indicates when a remote system is controlling the heater by displaying **Remote** in the display. When connecting the heater to a remote system, identify whether it is a two- or three-wire remote system. Select the appropriate instruction listed below to properly install the remote to the heater.

Off
Water Temp 69F

Off
No Demand

OFF Mode

Pool Set 65F
Water Temp 60F

Pool Set 65F
Heating

Heating in the POOL Mode

Spa Set 65F
Water Temp 60F

Spa Set 65F
Heating

Heating in the SPA Mode

Remote
Water Temp 69F

Remote
No Demand

Remote Mode

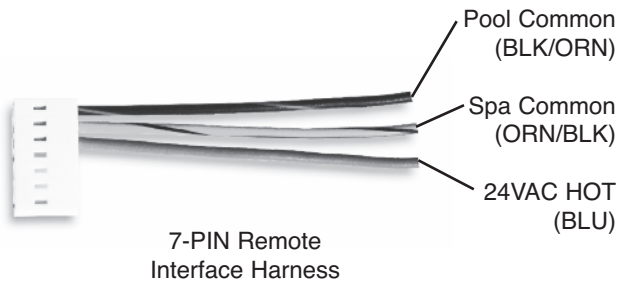

REMOTE OPERATION

The AFT model heaters are equipped with the ability to work with external remote controls. The supplied 7-pin remote wiring connector supplies power out to either a toggle switch or the switch contacts of a third party remote. The remote works by either making or breaking the circuit created by the remote wiring. Typically, a remote does not supply power to the heater, it only provides a switching function to turn the heater On or Off. **If your remote is supplying its own voltage to the heater, it will not work with this heater and may damage the digital circuit board.**

For operation of the heater using the onboard thermostat controls with a time clock, see the "Time Clock / Fireman's Switch" section.

ACTIVATING THE REMOTE

To activate or deactivate the remote function, follow these steps:



Press and hold the UP and DOWN arrow buttons for 3 to 5 seconds.

The second line of the display will alternate even when the unit is off ("No Demand").

Remote Pool 65F
Water Temp 60F

Remote Pool 65F
Heating

Remote Spa 65F
Water Temp 60F

Remote Spa 65F
Heating

NOTE: When in remote operation, the keypad mode and temp buttons are disabled.



Note: Electrostatic Discharge (ESD) damage can be caused by direct or indirect contact with the wiring or circuit board. When one walks to the heater area, an electrostatic charge accumulates on the body. Contact of a finger allows the body to discharge, possibly causing device damage. This damage can be limited if the service person discharges himself, following ESD preventive/removal practices, and holds on to the heater enclosure for 5 seconds before proceeding.

REMOTE CONTROL WIRING

Important Installation Notes for Remote or External Wiring Configuration

- Remote wiring must be run in a separate conduit.
- Remote wiring must not be run parallel to high voltage lines.
- For runs of under 30 feet (9.1m), remote wiring should have stranded conductors with a minimum of 22 AWG, 600V, cable twisting 1.5 to 2.5 in. (3.8 to 6.4cm) lay and jacketed.
- For runs over 30 feet (9.1m), the conductors should be a minimum of 20 AWG, 600V, cable twisting 1.5 to 2.5 inch (3.8 to 6.4cm) lay that is shielded and jacketed.
- Maximum cable length is 200 feet.
- For both two- and three-wire remote systems, the provided 7-pin wiring connector must be utilized. Please refer to the wiring instructions.

NOTE: The remote wires must be connected to the 7-pin connector **before** the connector is plugged into the board.

2-Wire Remote Control (On-Off)

This application assumes that only one heating function (pool or spa) is required.

1. Turn on power to the heater.
2. For a 2-Wire Remote Control from a remote without its own sensor, push the MENU/SET button to the "POOL" or "SPA" mode and set the desired setpoint (eg. 102 °F (39°C) for Spa).
3. For a 2-Wire Remote Control from a remote with its own sensor, push the MENU/SET button "POOL" or "SPA" mode and set the temperature to the highest setting available on the control. The actual setpoint will be controlled by the remote control.
4. Turn the MENU/SET button to "OFF" and remove power from the heater.
5. On the "Remote Interface Harness", connect the BLUE wire to one side of the "REMOTE" switch and connect the other side to either the ORANGE/BLACK wire for "SPA" operation or the BLACK/ORANGE wire for "POOL" operation.
6. Attach wire nut on unused wire to the "Remote Interface Harness."
7. Install the "7-Pin Remote Interface Harness" to the P8 connector and turn power "On" to the heater.

To activate the remote control, see page 23.

3-Wire Remote Control Using Three-Position Switch (Pool-Off-Spa, or Low-Off-High)

This application assumes that both heating functions (pool and spa) are required.

1. Turn on power to the heater.
2. Push the menu/set button to the "POOL" or "SPA" mode and set the desired temperature for each (eg. 80°F (27°C) for Pool and 102°F (39°C) for Spa).
3. Turn the MENU/SET button to "OFF" and remove power from the heater.
4. On the "Remote Interface Harness" connect the BLUE wire to one side of the "REMOTE" switch and connect the ORANGE/BLACK wire for "SPA" operation and the BLACK/ORANGE wire for the "POOL" operation.
5. Install the "Remote Interface Harness" to the P8 connector and turn power "ON" to the heater.

To activate the remote control, see page 23.

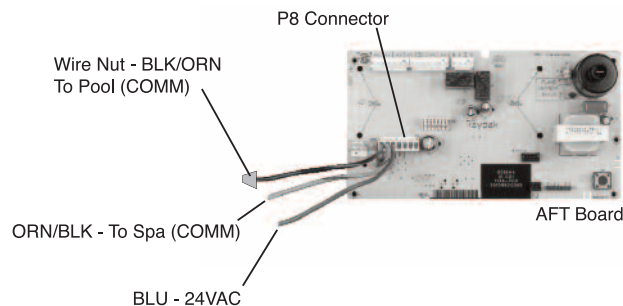

2-Wire Remote Control

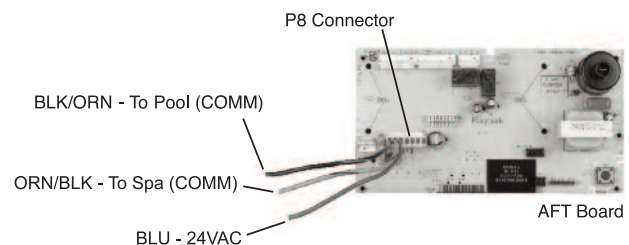

3-Wire Remote Control

Wiring Diagrams

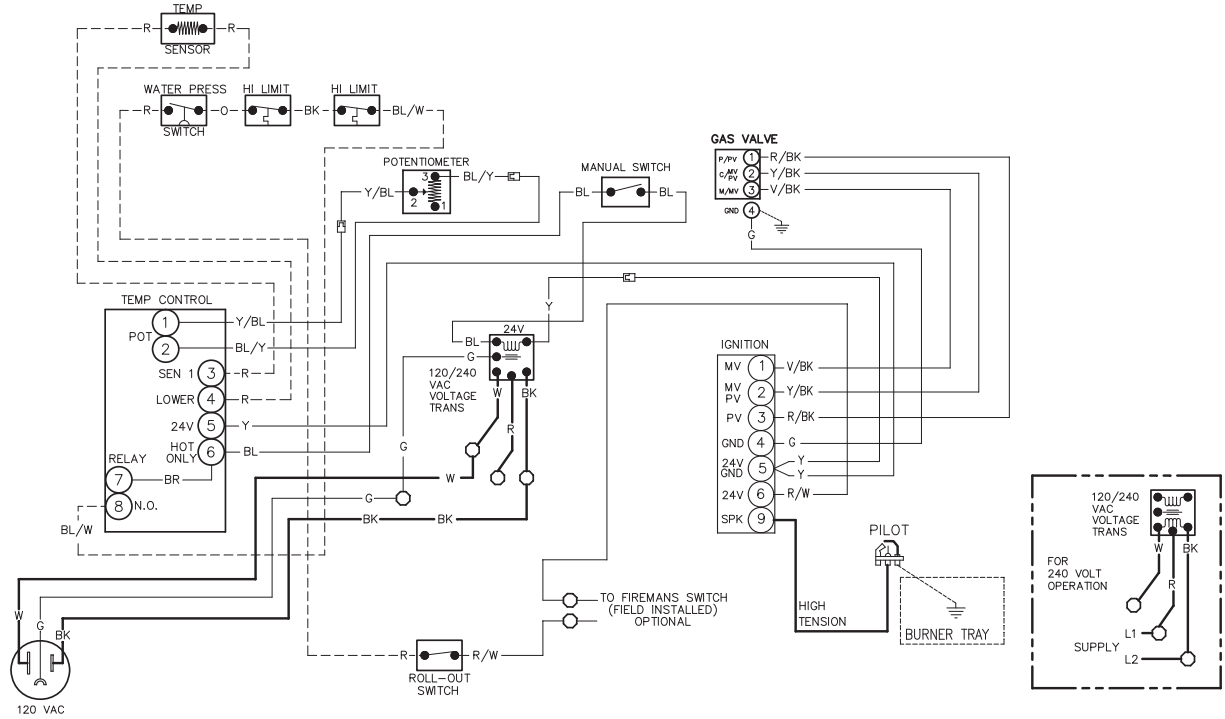

Fig. 19: Wiring Diagram—Analog Models

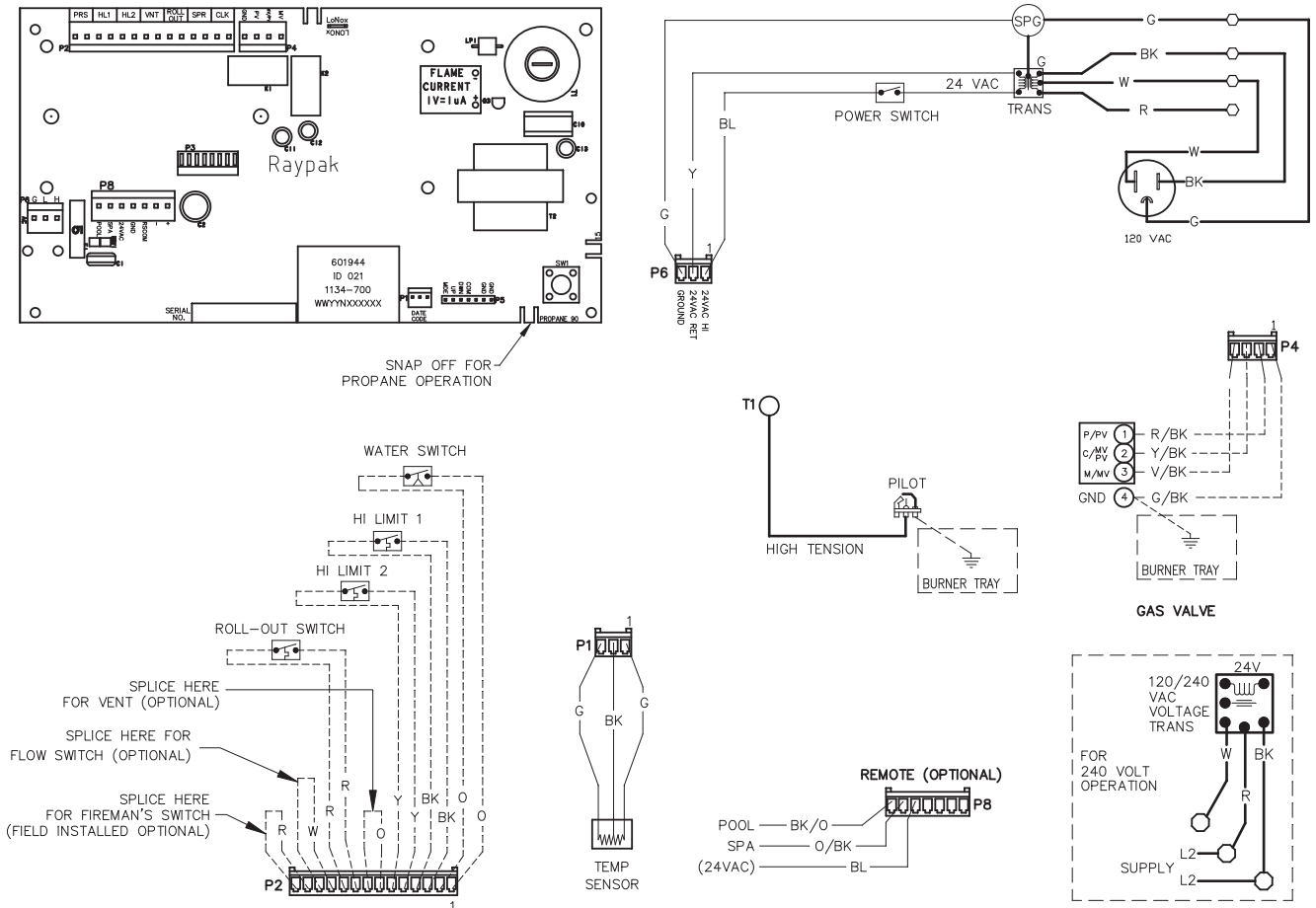

Fig. 20: Wiring Diagram—Digital Models

Time Clock/Fireman's Switch

To operate the heater with a time clock, connect the timer to the fireman's switch connection in the heater's wiring. The time clock should be of the dual switch type and set to shut off the call for heat to the pool heater (chauffe-piscine) 15 to 20 minutes prior to shutting down the pool pump. On analog heaters, splice into the red/white wire to connect the time clock. For digital heaters the fireman's switch connection is located on the 14-pin header connected to the digital control board. Splice into the red wire jumper tagged "Where necessary add "Fireman's" switch circuit here" to connect the time clock. **The fireman's switch connection on both analog and digital heaters must be a dry contact and must not supply power to the heater. Powering the fireman's switch connection externally may damage the heater, and is not covered by warranty.**

Digital heaters: Do not exceed 50ft (15.2 m) of total wiring using 18 AWG stranded copper wire rated for 221°F (105°C) minimum.

NOTE: When using a time clock, the heater will display "Clock/ Fireman Sw" when the fireman's switch is open, indicating that the time clock has shut off the call for heat.

Post Start-Up Inspection

Do not use this heater if any part has been under water. Immediately call a qualified service technician to inspect the heater and to replace any part of the control system and any gas control which has been under water.

N'utilisez pas cet appareil s'il a été plongé dans l'eau, même partiellement. Faites inspecter l'appareil par un technicien qualifié et remplacez toute partie du système de contrôle et toute commande qui ont été plongés dans l'eau.

WARNING: Should overheating occur or the gas supply fail to shut off, turn off the manual gas control to the appliance.

AVERTISSEMENT: En cas de surchauffe ou si l'alimentation en gaz ne s'arrête pas, fermez manuellement le robinet d'arrêt de l'admission de gaz.

Feel the inlet and outlet pipes. Outlet pipe should be only slightly warmer than the inlet. It should not be hot. With the heater on, remove the door and make a visual check of the burner.

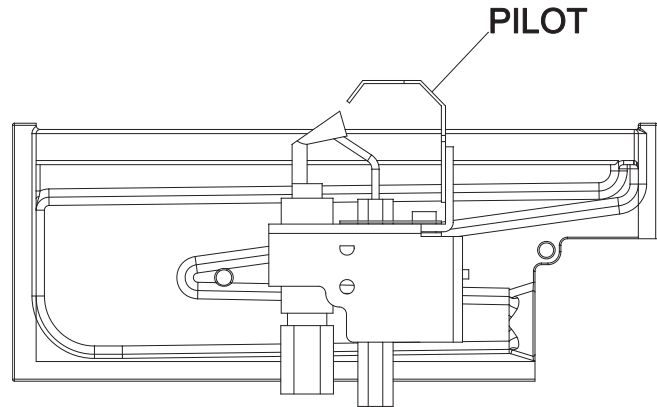

Fig. 21: IID Pilot Location

Cold Weather Operation

Moderate Climate

Heater operation can continue during short-term cold spells. When temperatures are between 0° (-17°C) and 32°F (0°C), flow (continuous pump operation) must be maintained.

CAUTION: Do not use the heater to maintain water temperatures just above freezing or for freeze protection. When heater is used during freezing weather, care must be taken to avoid freeze-ups. Continuous pump operation is a must. Additional protection may be required. The heater is not warranted against freeze-ups.

Cold Climate

Prolonged operation with water temperatures below 50°F (10°C) is not recommended. When starting the heater with water temperatures below 50°F (10°C), operate the heater continuously until higher temperatures are reached. Operating the heater for prolonged periods with pool water below 50°F (10°C) can seriously damage the heater, and is not covered by the warranty.

For cold climate areas, please follow the winterizing procedures listed in the next section.

Winterizing the Pool/Spa Heater (chauffe - piscine)

Heaters installed outdoors in freezing climate areas may be shut down for the winter. Observe the following procedure for winterizing the heater.

1. Turn off gas valve, manual gas valve, and electrical supply to the heater.
2. Open the drain plug located on the In/Out header, under the water pipes.
3. Remove the 2 wires from the water pressure switch and unscrew the water pressure switch to break any vacuum in the system. Remove the pressure switch and dry it before re-installing. Excessive moisture in the pressure switch may freeze, damaging the switch.

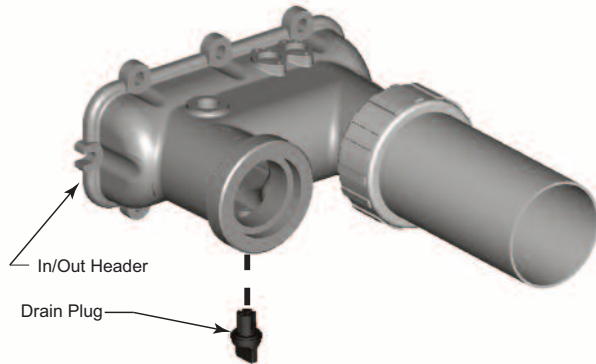

Fig. 22: In/Out Header Drain Plug Location

MAINTENANCE

The following preventative maintenance is to be performed one month after start-up and semi-annually thereafter.

1. Inspect top of heater and draft hood for soot, a sticky black substance around finned tubes and "V" baffles, and open flue gas passageways. Any visible soot should be cleaned for proper operation. See the De-sooting Procedure in the Service Section.
2. Clean main burners and pilot burner of dust and lint.
3. Inspect and operate all controls, gas valve and pressure relief valve (if equipped).
4. Make visual check of the burner and pilot flames. Flame pattern on the main burner and pilot is illustrated in the Post Start-Up Inspection section. Yellow flame means restriction of the air openings. Lifting or blowing flame indicates high gas pressure. Low flame means low gas pressure. Should these occur, shut the heater off and contact your gas supplier or qualified service agency.

5. On indoor heaters, clean room intake openings to ensure adequate flow of combustion and ventilation air.
6. Keep area around heater clear and free from combustible materials, gasoline and other flammable and corrosive vapors and liquids.

SERVICE

Verify proper operation after servicing.

S'assurer que l'appareil fonctionne adéquatement une fois l'entretien terminé.

Water Pressure Switch

The water pressure switch, ensures that the heater operates only when the filter pump is in operation. It is located on the In/Out header. It is factory set at 1.75 PSI (12kPa) for deck-level installations. When the heater is located below the level of the spa or pool, it may be necessary to adjust the pressure switch to compensate for the no-flow static head. If it is necessary to adjust the water pressure switch, utilize the following procedure.

CAUTION: Do not adjust the pressure switch until all air has been evacuated from the system and the water flow rate meets the requirements listed in Table H.

Water Pressure Switch Adjustment

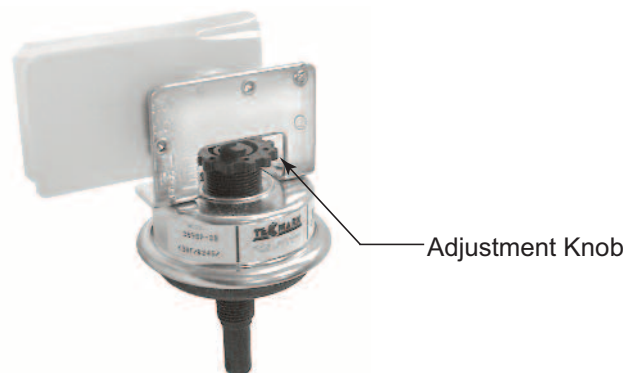

Fig. 23: Water Pressure Switch Adjustment

1. With pump and heater on, turn adjustment knob clockwise until a click is heard from the gas valve.
2. Turn adjustment knob counter-clockwise 1/4 turn.

3. Turn pump off and on several times. Heater should shut off immediately. If it does not, repeat the above steps.

NOTE: If heater is installed outside of the limits shown, a higher pressure rated 11 psi (76 kPa) switch may be used. A flow switch, mounted and wired adjacent to the heater, may be used in place of the factory mounted pressure switch. See Illustrated Parts List for 11 psi (76 kPa) water pressure switch.

Two-Speed Pumps

In some cases, the flow on the low-speed is insufficient to operate the heater. This is apparent when the water pressure switch cannot be further adjusted or if the heater makes banging noises or shuts off on high limit. In these cases, the pump must be run at high speed when heating the water.

CAUTION: Do not operate the heater without the function of a properly adjusted water pressure switch or flow switch.

Pilot Safety

The heater employs a pilot safety which closes the main gas valve within 8/10ths of a second whenever the pilot flame is interrupted. The pilot flame is automatically lit when the device is powered. The heater performs its own safety check and opens the main valve only after the pilot is proven to be lit.

Flame Roll-Out Safety Switch



Fig. 24: Flame Roll-Out Safety Switch

Heaters are equipped with a thermal cutoff device to prevent flame roll-out in the event the heat exchanger becomes blocked. This is a "single-use" type fusible link or thermal fuse, that must be replaced when disabled by an over-temperature condition, caused by excessive restriction in the heat exchanger flue passage, roll-out, high winds, etc.

High Limits

The heater is equipped with two automatic high limits. Both are located in the In/Out header. Both are set to open at 135°F (57°C).

NOTE: An erratic high limit is often characteristic of an internal heat exchanger problem, e.g. scale build-up, defective bypass. Refer to Troubleshooting section.

High Limit Removal



Fig. 25: High Limit Switch

1. Shut off main electrical power switch to heater.
2. Remove rear In/Out inspection panel.
3. Remove defective high limit and replace with a new high limit.
4. Replace inspection panel.

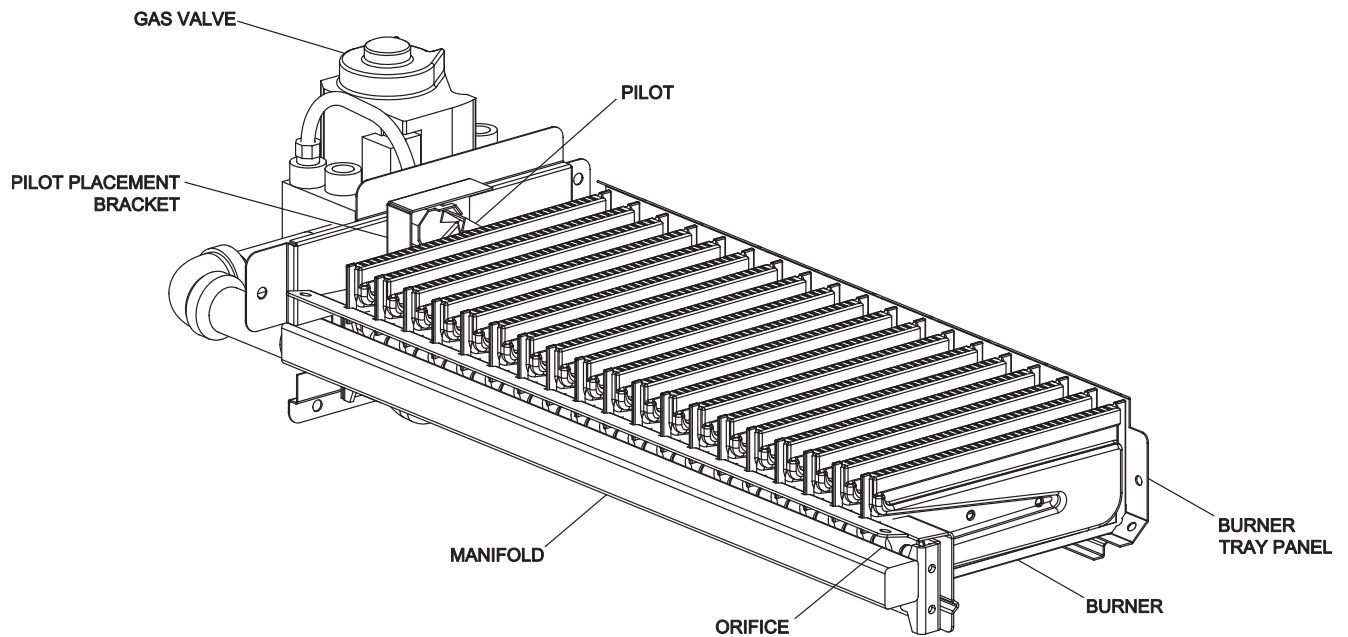

Fig. 26: Burner Tray Assembly

Burner Tray Removal

- 1 Shut off main electrical power switch to heater.
- 2 Shut off gas upstream of heater.
- 3 Remove front door
- 4 Disconnect gas line from gas valve.
- 5 Remove (3) screws holding the anti-rotation bracket in place.
- 6 Remove bracket and set aside.
- 7 Remove (4) screws as shown in the image.
- 8 Disconnect wiring from gas valve.
- 9 Remove (2) screws holding the control panel up.
- 10 Flip the control panel forward.
- 11 Disconnect ignition wire and remove with burner tray.
- 12 Reverse above procedure to reinstall.

Gas Valve Removal

- 1 Remove burner tray.
- 2 Disconnect pilot tubing from gas valve
- 3 Rotate the gas valve counter clockwise to remove valve from nipple.
- 4 Reverse above procedure to reinstall.

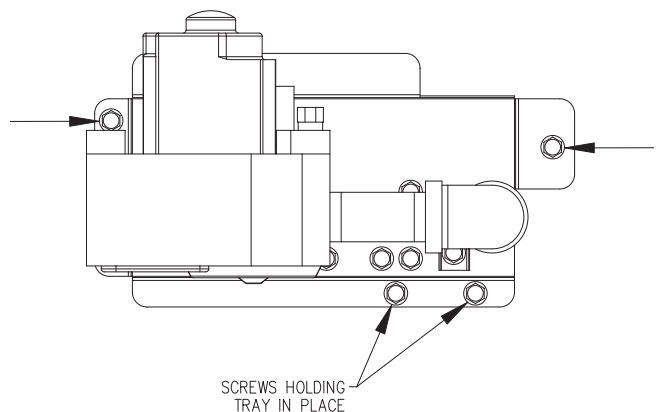

Fig. 27: Gas Valve Removal

Pilot Removal & Cleaning

- 1 Remove burner tray from heater
- 2 Disconnect tubing from gas valve.
- 3 Remove (2) screws holding pilot bracket in place. see image.
- 4 Remove the pilot assembly by pushing the pilot
- 5 Remove the locating pilot screw from the bracket to release the pilot assembly.
- 6 Reverse above procedure to reinstall

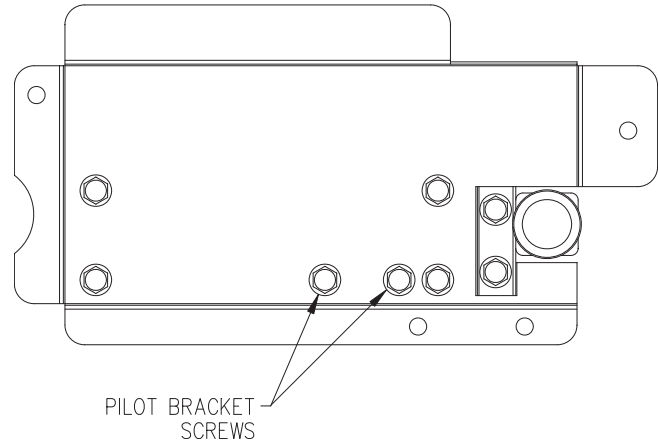

Fig. 29: Pilot Bracket Screws

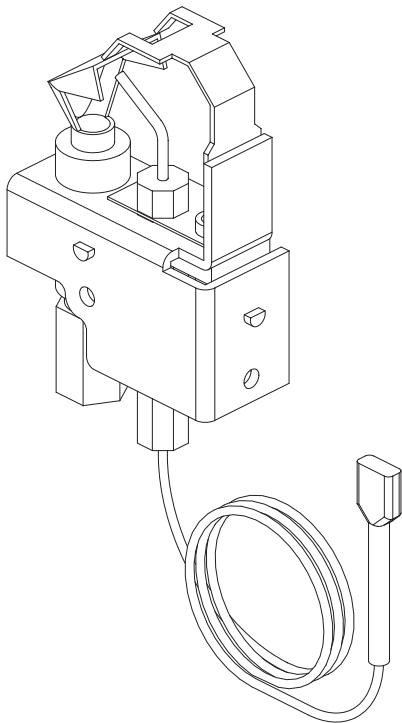

Fig. 28: Spark to Hood Pilot

Heat Exchanger Removal

1. Shut water, gas and electricity off, close valves and relieve pressure, then remove relief valve. Remove side inspection panels.
2. Remove the (8) top jacket holding screws. Remove the jacket top.
3. Remove the screws holding down the flue collector. Remove the flue collector.
4. Remove upper in/out access panel.
5. Disconnect all electrical wiring from in/out header.
6. Remove temperature sensor from in/out header.
7. Disconnect flange nuts on In/Out header.
8. Lift heat exchanger straight up using caution not to damage refractory.
9. Reverse above procedure to reinstall.

Tube Cleaning Procedure

Establish a regular inspection schedule, the frequency depending on the local water conditions and the severity of service. Do not let the tubes clog up solidly.

NOTE: Please remove heat exchanger from heater prior to reaming or removing debris.

Clean out deposits over 1/16" (0.16cm) in thickness. Use the Tube Cleaning Kit #052871F to ream the tubes as necessary. After reaming, mount the wire brush in place of the auger and clean out debris remaining in the tubes.

Another method is to remove the heat exchanger, ream tubes and immerse heat exchanger in non-inhibited de-scale solvent for severe scale build-up.

De-sooting Procedure

CAUTION: Soot may be combustible. Wet sooted surfaces completely prior to cleaning. Do not use steel wire brush.

Soot will clog areas between fins and cause eventual tube failure. Any sign of soot at the base of the burners or around the outer jacket indicates a need for cleaning.

1. Remove top and flue collector from cabinet.
2. Remove burner tray.
3. Remove heat exchanger from the heater and wash with a garden hose, making sure soot is removed from spaces between fins.
4. Reverse above procedure to reinstall.

NOTE: In extreme cases it may be necessary to do high-pressure cleaning at a local car wash. **DO NOT WIRE BRUSH.**

Replacement Parts

NOTE: When ordering parts, it is important that the heater model number, serial number, and type of gas are specified.

Any part returned for replacement under standard company warranties must be properly tagged with a return parts tag, completely filled in with the heater serial number, model number, etc., and shipped to the Company freight prepaid.

If determined defective by the Company and within warranty, a like part or equal substitution will be returned, freight collect. Credit will not be issued.

**MANUFACTURER:
2151 EASTMAN AVENUE
OXNARD, CA 93030**

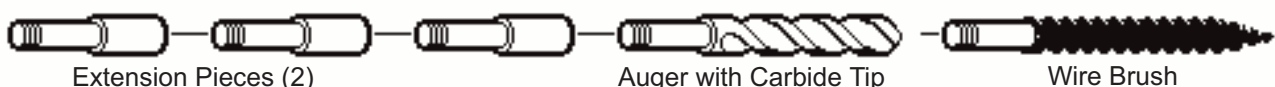

Fig. 30: Tube Cleaning Kit

TROUBLESHOOTING

Mechanical

IMPORTANT NOTICE These instructions are intended for the use of qualified personnel who are specifically trained and experienced in the installation of this type of heating equipment and related system components. Installation and service personnel may be required by some states to be licensed. Persons not qualified shall not attempt to install this equipment nor attempt repairs according to these instructions.

PROBLEM	CAUSE	SOLUTION
Harmonics, or whining noise	U.G. inoperative.....	Check movement by putting in hot water (110°F (43.3°C) or higher). If no movement, replace.
	*Debris or restriction in system.....	Locate the restriction and remove. Flush system and clean.
	*Debris in gas line.....	Remove debris or blow out gas line.
	Low flow.....	Scale forming in heat exchanger - clean heat exchanger and check pool pH and total alkalinity.
Heater going on and off continuously	Dirty filter.....	Clean or replace filter.
	Low water level in pool.....	Raise water level.
	External bypass setting out of adjustment.....	Adjust bypass.
	*Pressure switch out of adjustment....	Adjust pressure switch.
Liming or scale forming in exchanger	Pool water.....	See Water Chemistry on page 5.
	Bypassing too much water.....	Inspect bypass for movement, if no movement, replace.
	U.G. not functioning.....	Replace if no movement when heated.
Sooting	High flow rates.....	Reduce by adding manual bypass valve. Adjust manual bypass valve until heater outlet water temperature is between 105°F and 110°F (40.5°C and 43.3°C).
	U.G. Inoperative.....	Check movement by putting in hot water (110°F (43.3°C) or higher). If no movement, replace.
	*Air starvation.....	Refer to installation instructions.
	*Improper venting.....	Follow recommended installation instructions.
	*Insects or debris clogging burner intake ports.....	Clean burners.
Pilot outage or "Weak Flame" signal	Low gas pressure.....	Adjust gas pressure.
	Restricted/dirty pilot.....	Clean pilot and/or electrode.
	Weak pilot generator.....	Replace pilot.
Yellow lazy flame	Low gas pressure.....	Adjust gas pressure.
	*Insects or debris clogging burner intake ports.....	Clean burners.
Outer jacket very hot (paint blistered)	*Broken refractory caused by shipping damage or improper combustion..... Excessive sooting of heat exchanger..	Replace refractory panels. Determine cause of sooting & correct.
Takes too long to heat pool or spa	Under-sized heater.....	Calculate heating capacity of heater: $\frac{\text{Htr. output(BTUH)}}{\text{Pool gallonage} \times 8.33}$ or refer to heater sizing chart. This does not take into account heat loss due to weather.
	Filter not running long enough.....	Reset time clock.
	Dirty filter.....	Clean filter.
	Gas line or meter undersized.....	Refer to installation instructions.
Leaking at well	Overacid.....	Replace well and maintain proper water chemistry.
Leaking at heat exchanger	Overacid.....	Replace heat exchanger and maintain proper water chemistry.
Gasket brittle and leaking - (overheated)	Heater running after pump shuts off....	See Pressure Switch Adjustment.
	Refractory damage.....	Replace refractory.
	Sooted heater.....	Determine cause of sooting and correct.

* Indicates symptom which usually occurs on initial start-up.

ELECTRONIC CONTROL LOGIC - FLOW CHART

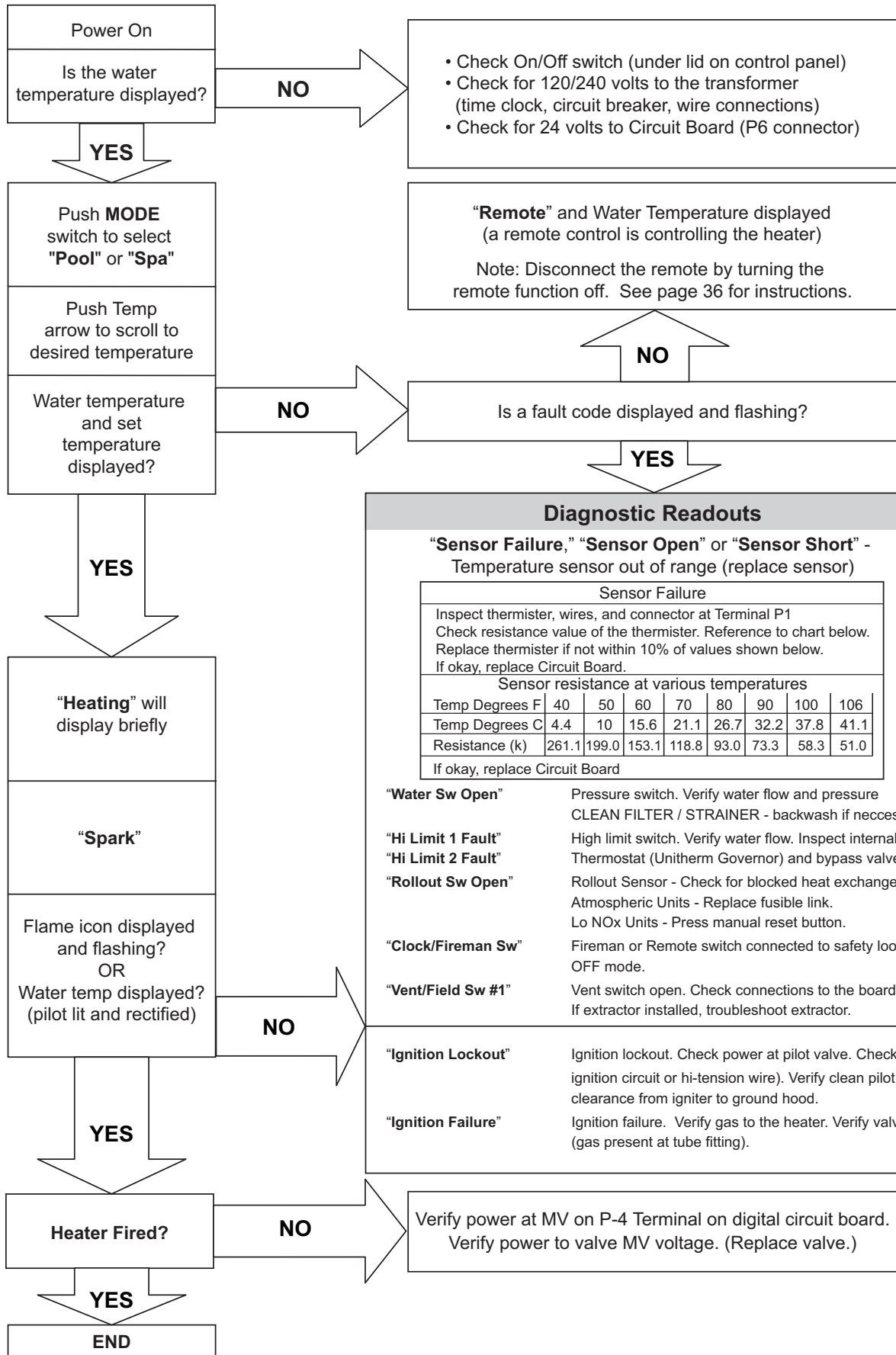

ANALOG CONTROL LOGIC - FLOW CHART

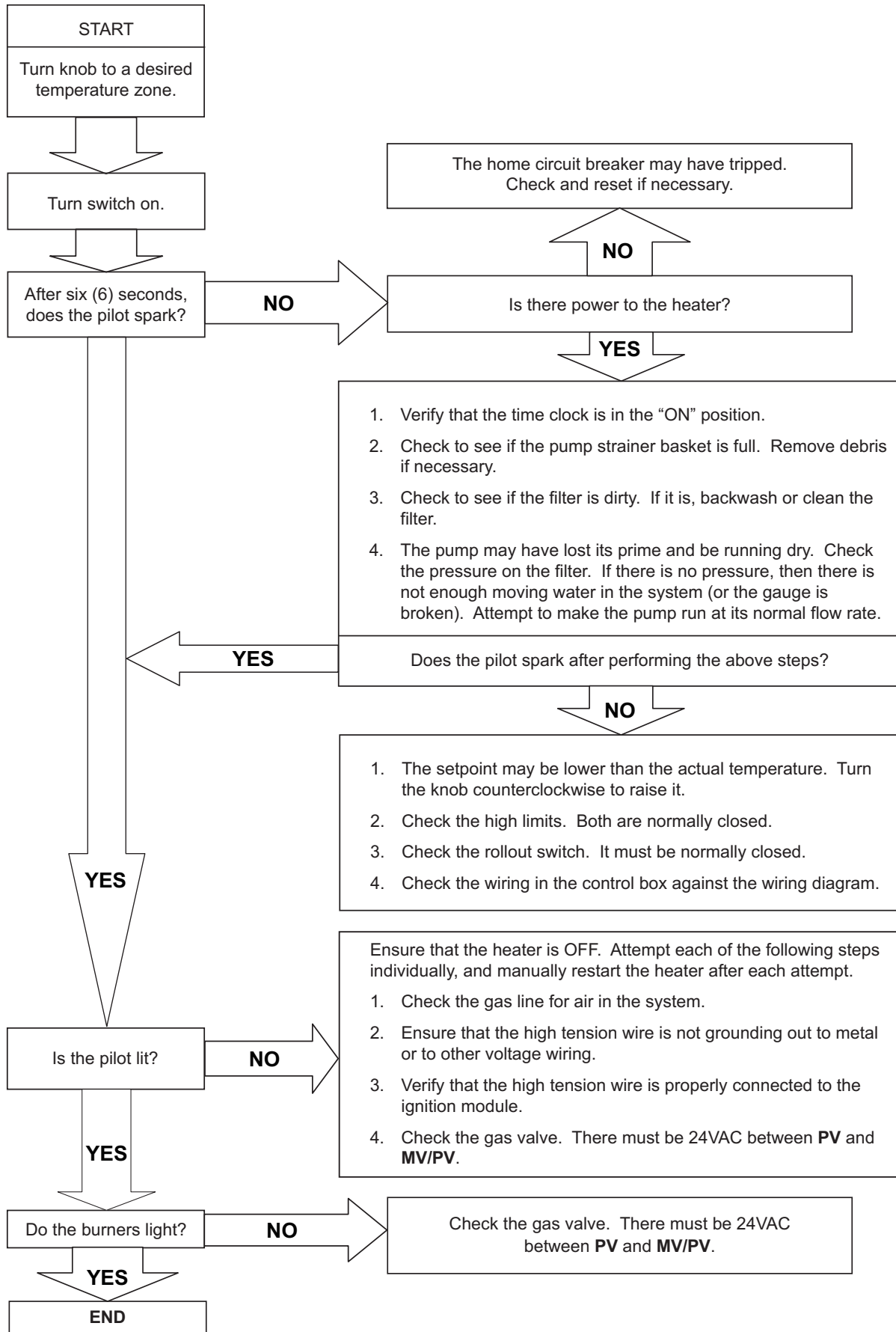

ILLUSTRATED PARTS LIST

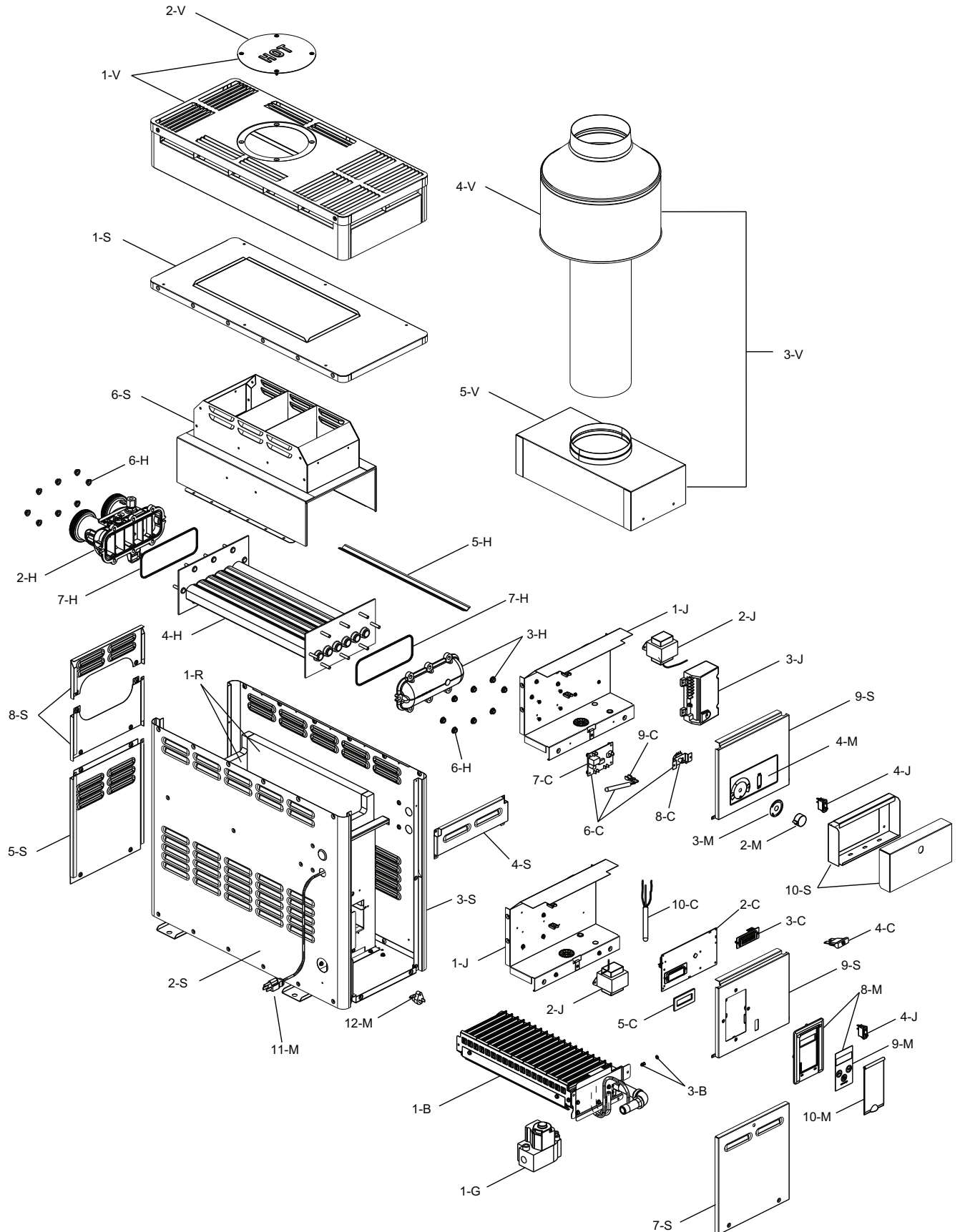

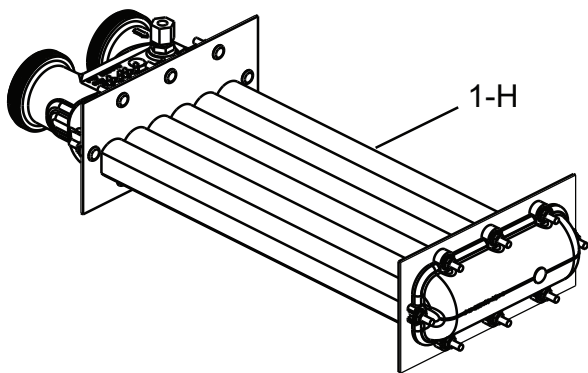
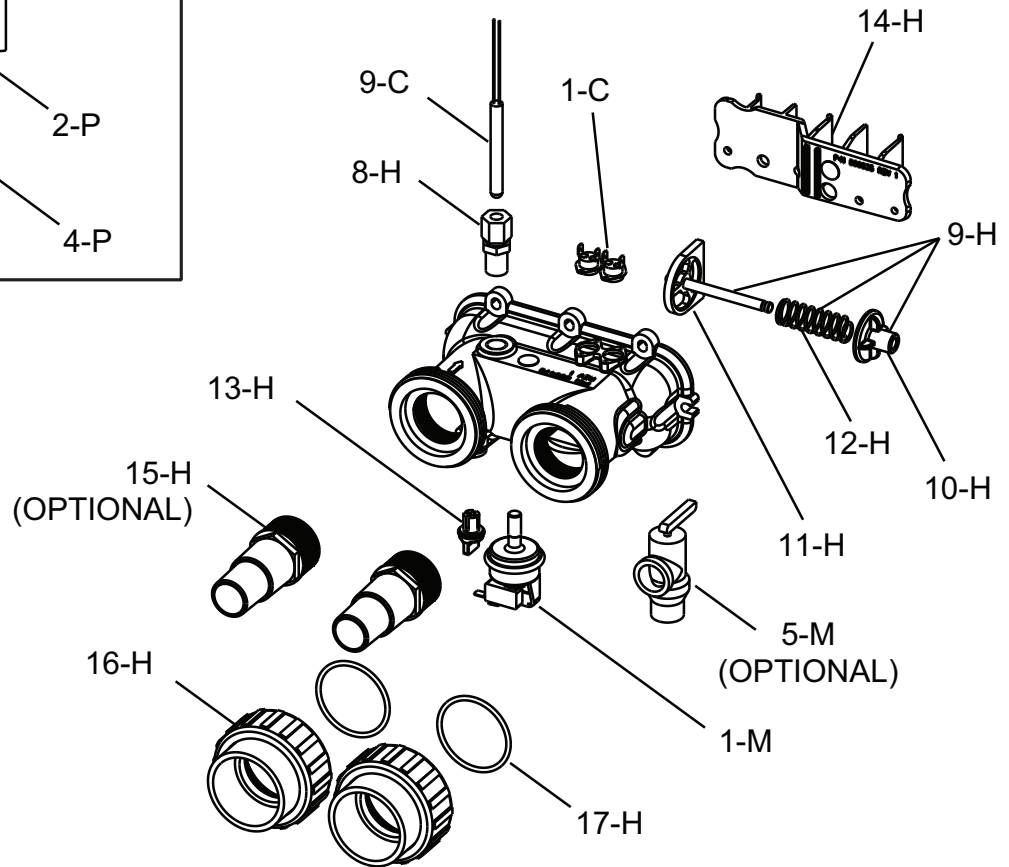
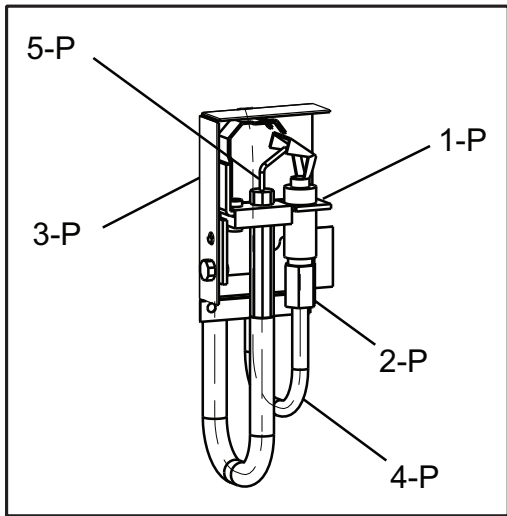

CALL OUT	DESCRIPTION	106A	156A
B	BURNER TRAY		
1-B	Burner Tray (Sea Level)* Natural Gas Propane Gas	014841F 014845F	014842F 014846F
	Burner Tray w/Gas Valve (Sea Level)* Natural Gas Propane Gas	014849F 014853F	014850F 014854F
2-B	Burner	N/A	N/A
3-B	Burner Orifice (Sea Level)* Natural 1.30mm Propane .84mm	014857F/13 014861F/13	014858F/19 014862F/19
C	CONTROLS		
1-C	Thermostat Auto Reset 135° Surface Mount	006725F	006725F
2-C	P. C. Board/Control (Digital)	N/A	013464F
3-C	LCD Display	N/A	013640F
4-C	Fuse 5 AMP	N/A	013733F
5-C	Seal Gasket	N/A	014866F
6-C	Thermostat Control (Analog)	011585F	N/A
7-C	PC Board	014923F	N/A
8-C	Potentiometer	011586F	N/A
9-C	Temperature Sensor Analog (2 Wire)	011587F	N/A
10-C	Temperature Sensor Digital (3 Wire)	N/A	009577F
G	GAS VALVE		
1-G	Combination Valve Nat. Combination Valve Pro.	014867F 014868F	014867F 014868F
H	HEAT EXCHANGER		
1-H	Heat Exchange Assy Copper	014869F	014870F
2-H	Inlet/Outlet Header Complete Inlet/Outlet Header (Includes 6-H)	011594F 011595F	015547F 011595F
3-H	Return Header (Includes 6-H)	011596F	011596F
4-H	Tube Bundle Copper **	014874F	014875F
5-H	Baffle (Cupro Nickel)	N/A	N/A
6-H	Flange Nut Kit	008259F	008259F
7-H	O Ring Gasket (2)	011600F	011600F
8-H	Sensor Adapter	006714F	006714F
9-H	Bypass Kit	011601F	015548F
10-H	Bypass Valve	006716F	006716F
11-H	Bypass Dam / Shaft	006717F	006717F
12-H	Bypass Spring	011602F	011602F
13-H	Drain Plug	006721F	006721F
14-H	Inlet/Outlet Header Dam	014882F	014882F
15-H	Hose Adapter 1-1/2" MPT x 1-1/2" Hose (Optional)	011635	011635
16-H	2" CPVC Connector & Nut (2)	006723F	006723F
17-H	O Ring Seal (2)	006724F	006724F
J	CONTROL BOX		
1-J	Control Box Analog (Includes 7-C) Natural Gas Propane Gas	014883F 014913F	N/A N/A
2-J	Transformer 120/240/24V Analog Digital	011605F N/A	N/A 006736F
3-J	Ignition Control Natural Gas (Analog) Ignition Control Propane Gas (Analog)	004817B 004818B	N/A N/A
4-J	Rocker Switch	009493F	009493F

*FOR ALTITUDES ABOVE 2,000 FEET ABOVE SEA LEVEL, CONSULT THE FACTORY.

** **WARNING:** The Hydraulic conditions or water chemistry that caused the tube bundle to fail have very likely also damaged the bypass valve. We recommend you inspect the bypass assembly. Failure to do so could cause premature failure of this replacement part.

CALL OUT	DESCRIPTION	106A	156A
M	MISCELLANEOUS COMPONENTS		
1-M	Pressure Switch 1.75 PSI	006737F	006737F
	Pressure Switch 11 PSI Special-See Adj in Service Manual	009133F	009133F
2-M	Thermostat Knob	009499F	009499F
3-M	Knob Stop	006886F	006886F
4-M	Dial Plate (Analog)	014912F	N/A
5-M	PRV 125 PSI (Optional)	008091F	008091F
6-M	Delimiting Kit (not shown)	052871F	052871F
7-M	Wire Harness Analog (not shown)	014884F	N/A
	Wire Harness Digital (not shown)	N/A	014885F
8-M	Control Bezel Digital (Includes Switch Decal)	N/A	014886F
9-M	Switch/Decal-Membrane	N/A	014887F
10-M	Control Bezel Cover	N/A	014888F
11-M	Line Cord	011609F	011609F
12-M	Roll-Out Safety Switch	005899F	005899F
13-M	Touch-up Paint		
	Cool Dark Gray	750256	750256
	Warm Dark Gray	750258	750258
P	PILOT		
1-P	Pilot Nat.	002003F	002003F
	Pilot Pro.	002003F	002003F
2-P	Pilot Orifice Nat.	003903F	003903F
	Pilot Orifice Pro.	004308F	004308F
3-P	Pilot Mounting Bracket	014889F	014889F
4-P	Pilot Tube	004078F	004078F
5-P	Hi Tension Wire w/Pilot Electrode	N/A	N/A
R	REFRACTORY		
1-R	Refractory Kit	014890F	014891F
S	SHEETMETAL		
1-S	Jacket Top	014892F	014893F
2-S	Jacket Left	014894F	014895F
3-S	Jacket Right	014896F	014897F
4-S	Jacket Upper Front	014898F	014898F
5-S	Jacket Lower Rear	014899F	014899F
6-S	Flue Collector	014900F	014901F
7-S	Door Panel		
	Raypak	014902F	014902F
	Rheem	014903F	014903F
	Ruud	014902F	014902F
8-S	Access Panels	014904F	014904F
9-S	Control Panel		
	Analog	014905F	N/A
	Digital	N/A	014906F
10-S	Control Cover		
	Analog	014778	N/A
	Digital	N/A	N/A
V	VENTING		
1-V	Stackless Top (Outdoor)	014907F	014908F
2-V	Access Panel (Hot)	014909F	014909F
3-V	Drafthood w/Adapter (Indoor)	014357	014358
	Outdoor Stack w/Adapter (Outdoor)	014718	014719
4-V	Stack	N/A	N/A
5-V	Stack Adapter	014910F	014911F

CONVERSION KITS**		106A	156A
For Altitudes Over 2,000 Feet Above Sea Level, Consult Factory.			
Natural to Propane			
	Copper Heat Exchanger	014914F	014915F
	Cupro Nickel Heat Exchanger	N/A	N/A
Propane to Natural			
	Copper Heat Exchanger	014918F	014919F
	Cupro Nickel Heat Exchanger	N/A	N/A

** Gas Conversions are to be done only by a qualified agency.



www.raypak.com

Raypak, Inc., 2151 Eastman Avenue, Oxnard, CA 93030 (805) 278-5300 Fax (805) 278-5468
Litho in U.S.A.