

SUPPLEMENTAL INSTALLATION AND OPERATION MANUAL



THIS MANUAL CAN BE VIEWED ELECTRONICALLY USING YOUR SMART DEVICE. SEE PAGE 46 FOR QR CODE.



Raymote Wi-Fi Connectivity

NOTE: This equipment has been tested and found to comply with the limits for a Class A digital device, pursuant to part 15 of the FCC Rules. These limits are designed to provide reasonable protection against harmful interference when the equipment is operated in a commercial environment. This equipment generates, uses, and can radiate radio frequency energy and, if not installed and used in accordance with the instruction manual, may cause harmful interference to radio communications. Operation of this equipment in a residential area is likely to cause harmful interference in which case the user will be required to correct the interference at his own expense. The user is cautioned that changes and modifications made to the equipment without approval of the manufacturer could void the user's authority to operate this equipment.



Effective: 04-25-22
Replaces: 07-01-20
P/N 241788 Rev. 3

Revision 3 reflects the following changes:

Cover image updated with Application's new graphic user interface. Additional data added as needed to text and figures. Figures cleaned up. Updated Figures: 5-8, 11-17, 27-54, 57-59, 68, 71-72, 75-88, 92, 104-107. Troubleshooting information and figures added starting on page 37. Added XVers with KOR details.

TABLE OF CONTENTS

1. WARNINGS	4	7. WEB DASHBOARD	21
Pay Attention to these Terms	4	Device Dashboard.....	21
2. SYSTEM DESCRIPTION	5	Devices Timeline	21
3. COMPONENTS	5	Device Info	21
4. SERVICE KITS	5	Search Function	22
5. PROVISIONING PROCESS	8	How to Create an Organization.....	23
Preparing the Unit for Connection.....	9	How to Create a Location.....	25
Add a New Heater to Raymote	10	Analytics	27
For iPhone 6 and Earlier Versions	11	Update Boiler Data on Existing Devices	28
Boiler Profile Setup	14	Boiler Data from Web Dashboard	29
6. RAYMOTE MOBILE APP	15	Boiler Data from Mobile App	30
User and Organization Settings	15	Transfer Users and Devices.....	30
Help and Tech Support.....	16	Download Reports.....	33
Main View.....	17	Service Charts Tutorial.....	34
Automation	18	8. ROLES AND PERMISSION	37
View Screen	19	9. TROUBLESHOOTING	38
Boiler Screen.....	20	10. DISABLING RAYMOTE	42
Adjust Screen.....	20	11. QR CODE	46

1. WARNINGS

Pay Attention to these Terms

▲ DANGER	Indicates the presence of immediate hazards which will cause severe personal injury, death or substantial property damage if ignored.
▲ WARNING	Indicates the presence of hazards or unsafe practices which could cause severe personal injury, death or substantial property damage if ignored.
▲ CAUTION	Indicates the presence of hazards or unsafe practices which could cause minor personal injury or product or property damage if ignored.
CAUTION	CAUTION used without the warning alert symbol indicates a potentially hazardous condition which could cause minor personal injury or product or property damage if ignored.
NOTE	Indicates special instructions on installation, operation, or maintenance which are important but not related to personal injury hazards.

▲ WARNING: Do not use this boiler if any part has been under water. Immediately call a qualified service technician to inspect the boiler and to replace any part of the control system which has been under water.

▲ WARNING: Should overheating occur or the gas supply valve fail to shut off, do not turn off or disconnect the electrical supply to the boiler. Instead, shut off the gas supply at a location external to the boiler.

▲ WARNING: Risk of electrical shock. More than one disconnect switch may be required to de-energize the equipment before servicing.

▲ DANGER: Make sure electrical power to the heater is disconnected to avoid damage to components, potential serious personal injury or death. Make sure the gas to the heater has been shut off.

2. SYSTEM DESCRIPTION

Raymote enables wireless communication capability for Raypak heating products utilizing the VERSA IC[®] touchscreen controls. From anywhere with Internet connectivity, users can access boiler, pool or water heater information, control some functions, and receive notifications and reminders when the unit needs attention.

This manual describes Raymote components, and the process of installing, operating, commissioning, and troubleshooting the Raymote interface.

Raymote can also be added to existing units in the field utilizing the VERSA IC touchscreen.

3. COMPONENTS

The Raymote interface includes the following components:

1. **J-Box Panel Cover** - Panel cover with Wi-Fi antenna opening (MVB and XTherm only)
2. **Touchscreen Rear Cover** - Shields the electronic control
3. **Antenna Bracket** - Supports the Wi-Fi antenna installation (XVers only)
4. **Antenna Bracket** - Supports the Wi-Fi antenna installation (MVB and XTherm only)
5. **Antenna Bracket** - Support Wi-Fi antenna (XVersL, XVers with KOR and XFIIRE only)
6. **Wi-Fi Antenna** - Enhances wireless signal
7. **Wi-Fi Module*** - Enables Wi-Fi connectivity (mounts to the back of the VERSA touchscreen)
8. **Power Conditioner** - Prevents power line interference

9. **7" Touchscreen with built-in Wi-Fi Module** - Latest VERSA touchscreen is equipped with a built-in Wi-Fi module.
10. **4.3" Touchscreen** - With built in Wi-Fi module (XFIIRE and XVERSL only).
11. **SD Card** - Touchscreen software with Raymote support (Different SD card are used for 7" and 4.3" Touchscreen units).

4. SERVICE KITS

The following kits are available for field service:

Service Kits		Description
017198F	Swivel Antenna Kit	Wi-Fi antenna
017199F	Wireless Module Kit*	Wi-Fi module
017200F	EMI Filter Kit	Power conditioner
017201F	Touchscreen Rear Cover Kit	Touchscreen rear cover and bracket
015887F	SD Card for 7" Touchscreens	SD Card with Raymote for XVers, XVers w/ KOR, MVB and XTherm
018438F	7" Touchscreen with built-in Wi-Fi Module	Integrated Wi-Fi module in VERSA Touchscreen
017810F	4.3" Touchscreen with built-in Wi-Fi Module	Touchscreen for XFire/ and XVers L
017811F	SD Card for 4.3" Touchscreens	SD Card for XFire and XVers L only

Table A. Service Kits

NOTE: *Wi-Fi module is only required in legacy Touchscreens with socket. Latest VERSA Touchscreen comes with a built-in Wi-Fi module.

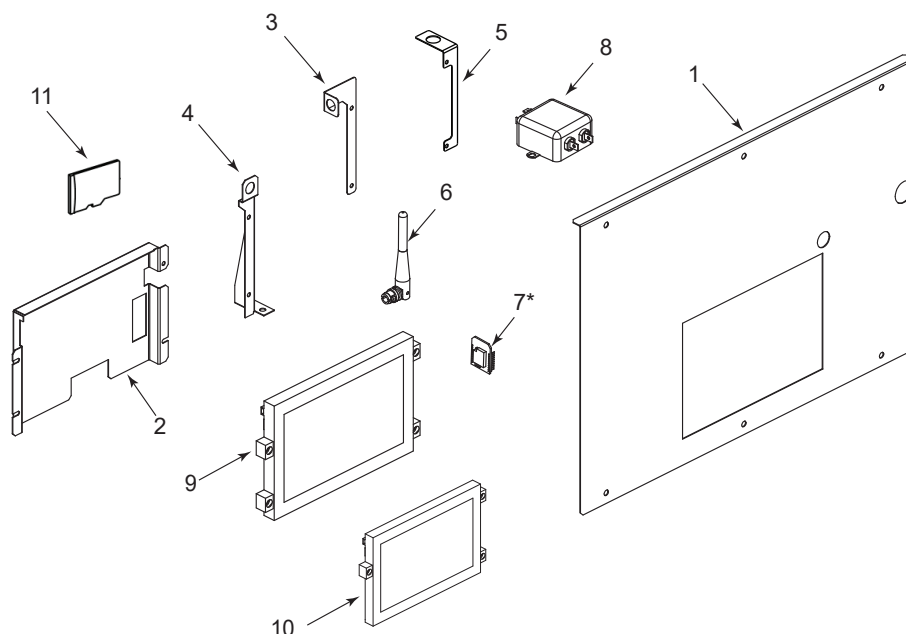

Figure 1. Raymote Components

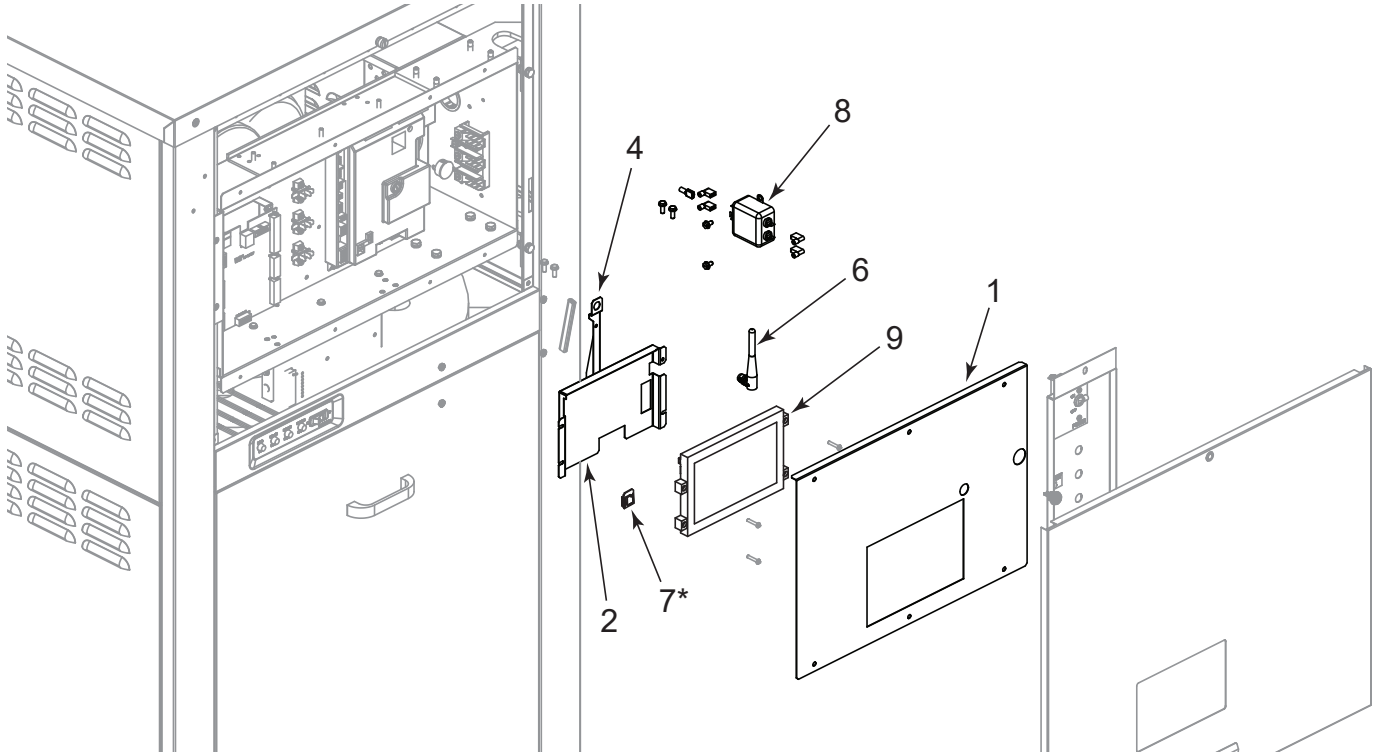

Figure 2. Raymote Installation on MVB and XTherm

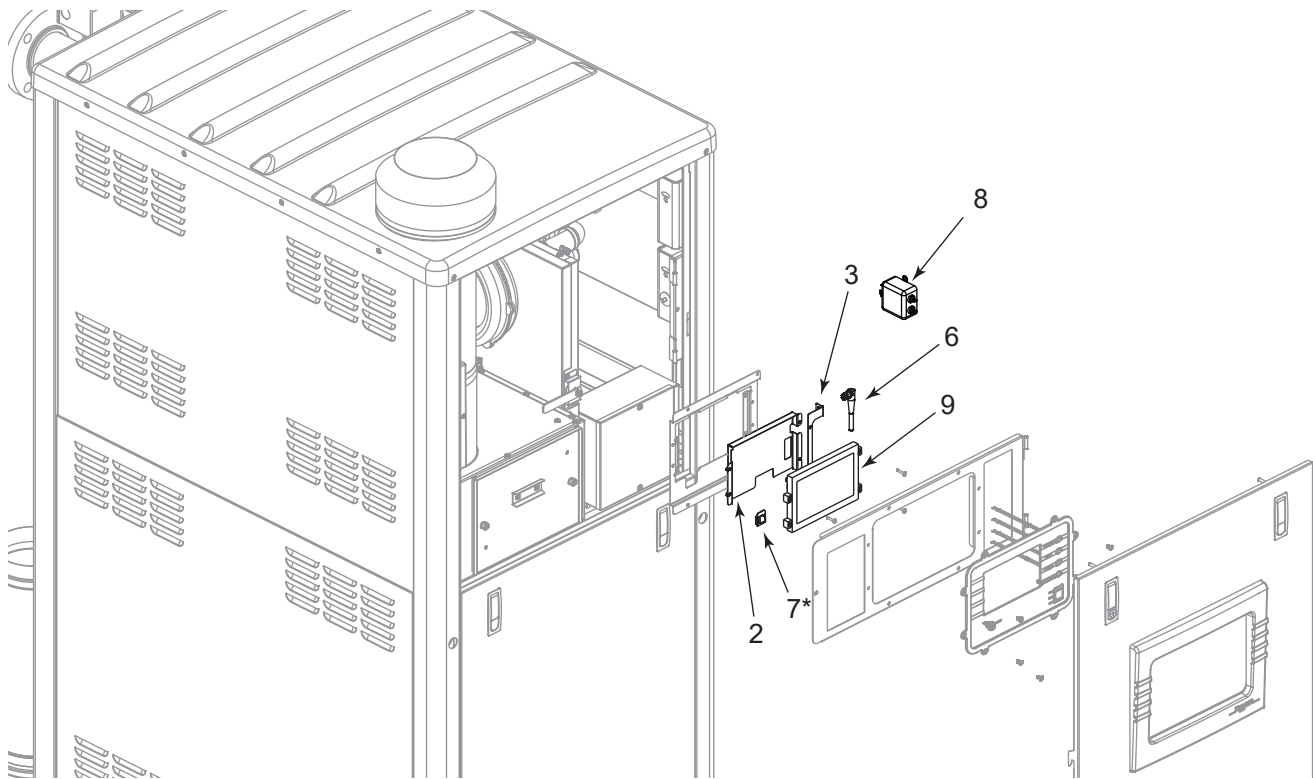

Figure 3. Raymote Installation on XVers

* Wi-Fi Module is built-in in latest models. Legacy VERSA screens can be equipped with a Raymote Wi-Fi module.

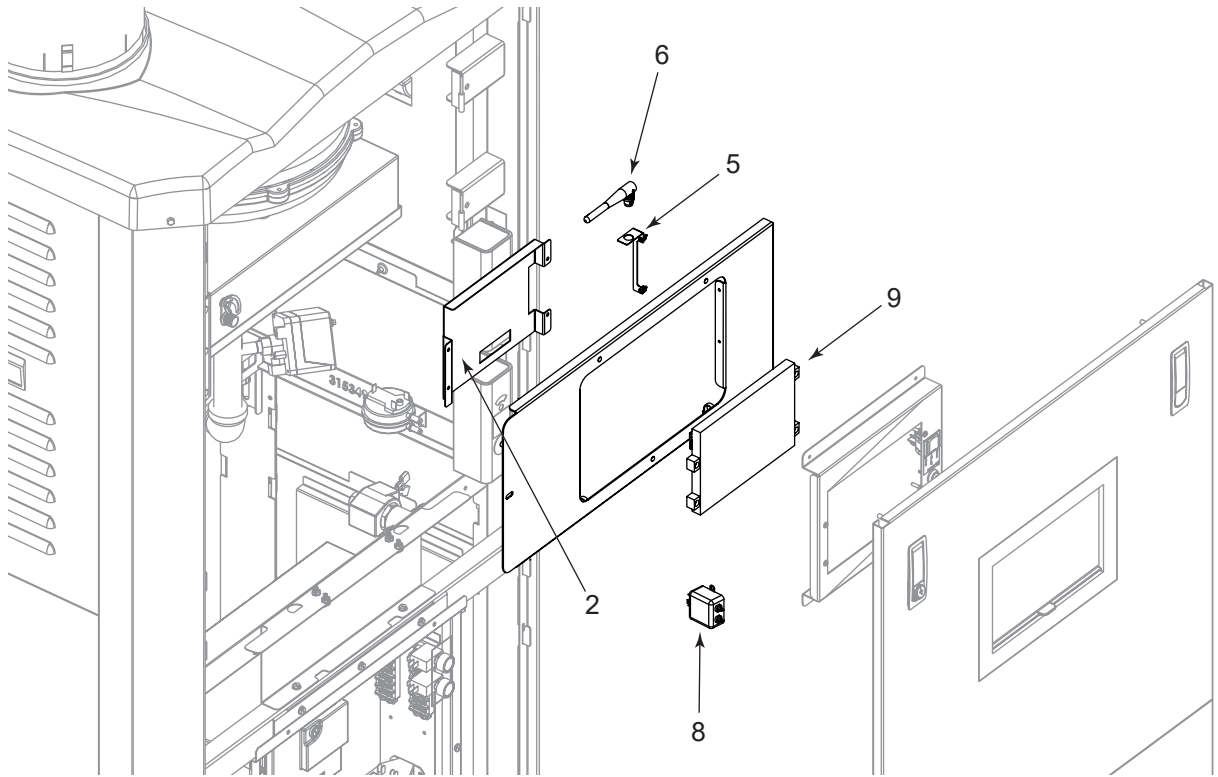

Figure 4. Raymote Installation on XVers with KOR

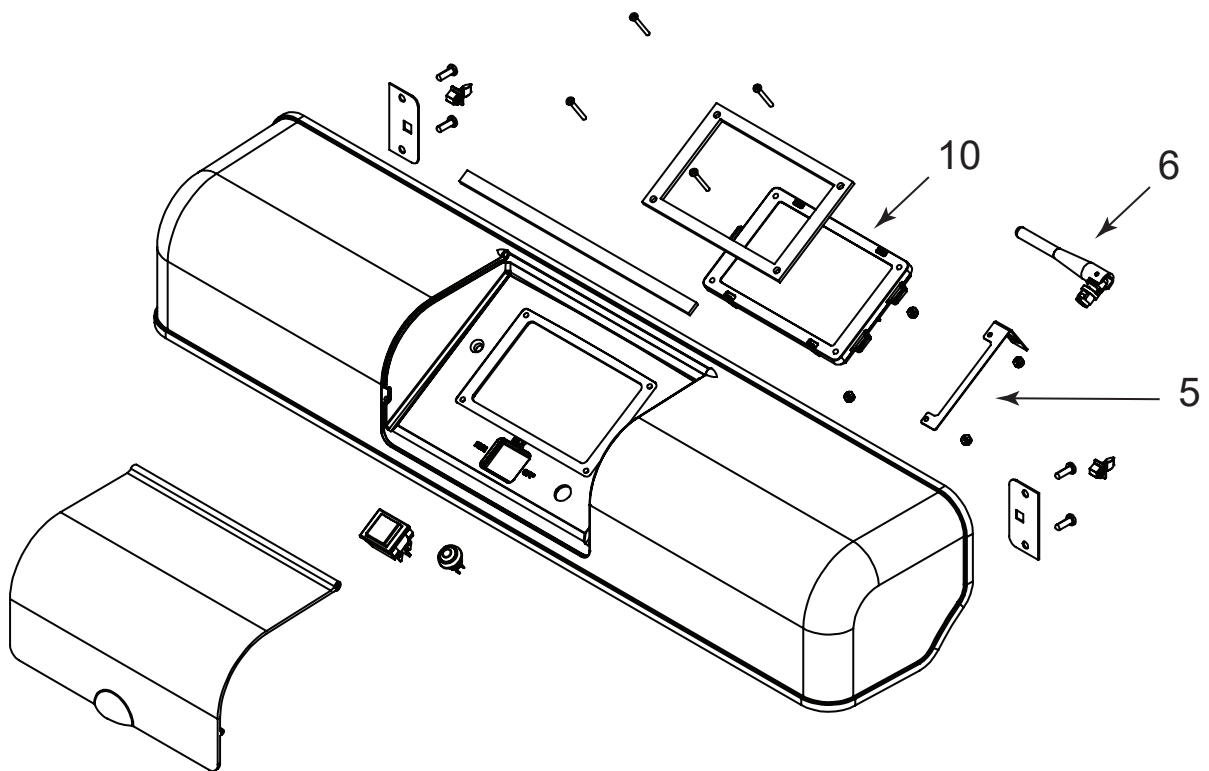

Figure 5. Raymote Installation on XFiire and XVers L

5. PROVISIONING PROCESS

Before initiating the provisioning process, make sure a reliable Wi-Fi access point is located near the unit or control room and a Wi-Fi network password is available.

Date: _____
Wi-Fi Network Name (SSID): _____
Wi-Fi Password: _____

Raymote User Registration Via Dashboard

Raymote user registration starts by receiving a formal invitation from another Raymote user or Raypak sales representative. See Figure 6.

<https://www.raypak.com/commercial-sales-rep/>

Use your email address as the Raymote user, then create a secure password. See Figure 7.

Once the user registration is complete, a user can begin to add new devices via the Raymote mobile app. See Figure 8.

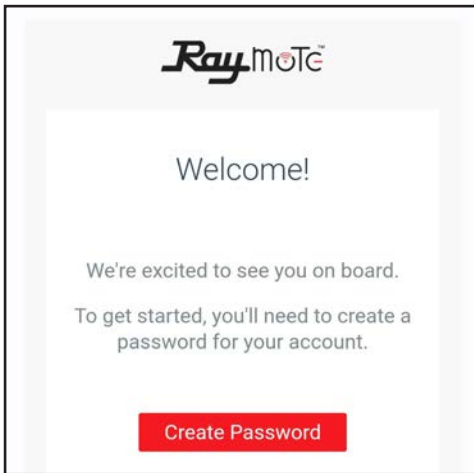

Figure 6. Welcome Raypak Dashboard

Create a password which is hard to guess.

PASSWORD

🔒 Password 👁

VERY WEAK

- Make it longer than 8 symbols
- Use uncommon words
- Use non-standard uPPerCaSing
- Use creatif spellllllling
- Use non-obvi0u\$ number\$ & symbo1s

Figure 7. Create Password

Downloading the Raymote Mobile App

1. Download the Raymote mobile app from the Google Play (Android) or App Store (Apple) on your mobile device.
2. Find the Raymote mobile app icon on your device. See Figure 8.

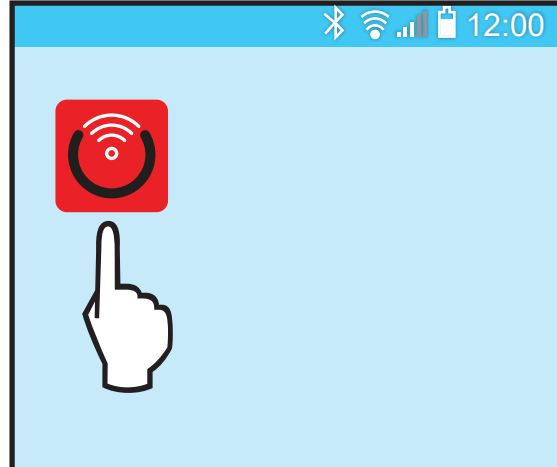

Figure 8. Find your Raymote Mobile App Icon

3. Open the Raymote mobile app and log in with your user name and password. See Figure 9.

EMAIL

✉ your.email@email.com

PASSWORD

🔒 Password 👁

Figure 9. Log in the Raymote Mobile App

Preparing the Unit for Connection

1. Stand near the touchscreen of the unit. Press the Wi-Fi icon on the touchscreen. See **Figure 10**.



Figure 10. Wi-Fi Connection

2. The Wi-Fi status screen should display the Wi-Fi State, indicating "Config Mode" wireless connection, and also the HOTSPOT identifier. See **Figure 11**.



Figure 11. Wi-Fi in Config Mode and HOTSPOT Identifier

NOTE: If the Wi-Fi State does not indicate "Config Mode", press the "Reset" button on the touchscreen. See **Figure 11**.

3. At this point your unit is ready for connection. The following sections provide the instructions for Android and iPhone devices.
4. In the Raymote app, press "+ Add a new device" for the first device or press the menu button  located at the top right corner of the screen, then press "+ Add a new device". See **Figure 12**.

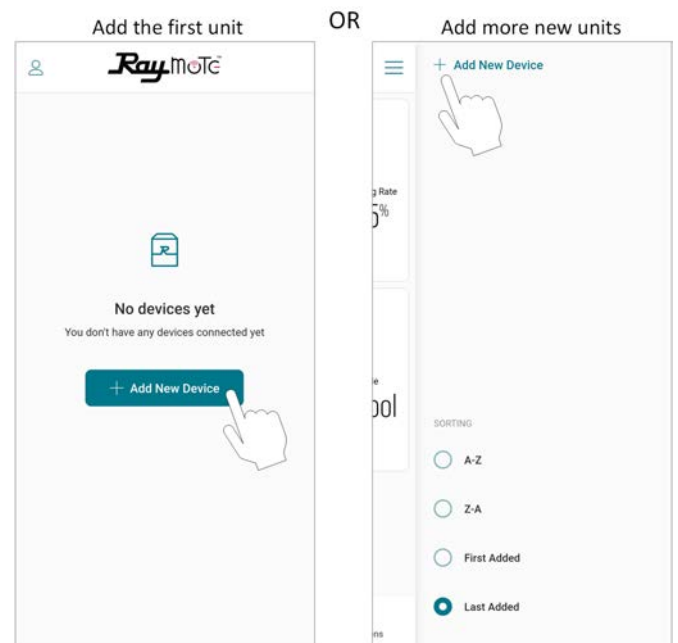

Figure 12. Add New Device

NOTE: The first time you use a new phone, the Raymote mobile app may require you grant permission to access data. See **Figure 13**.

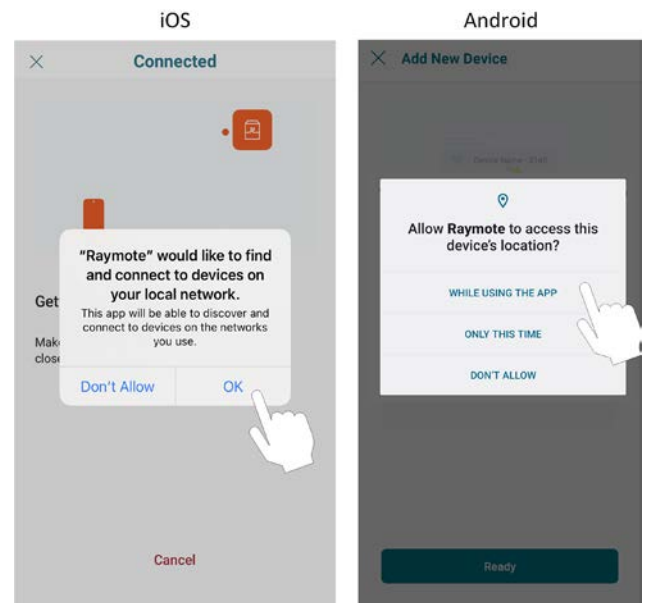

Figure 13. Grant Permission in iOS and Android

Add a New Heater to Raymote

1. "Check your Device" screen will appear. Ensure to have the heater powered and Wi-Fi signal available in the area, then press "Ready" button. See **Figure 14**.

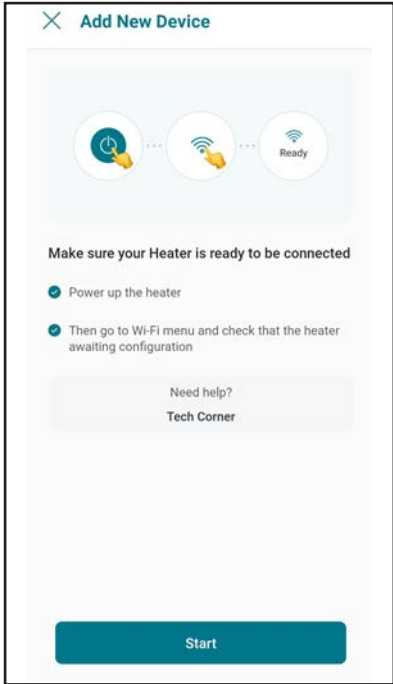

Figure 14. Check your Unit

2. **In Android:** Depending on your configuration, one or more devices will appear on the app. Select the HOTSPOT identifier that matches the unit's display as shown in **Figure 15**.

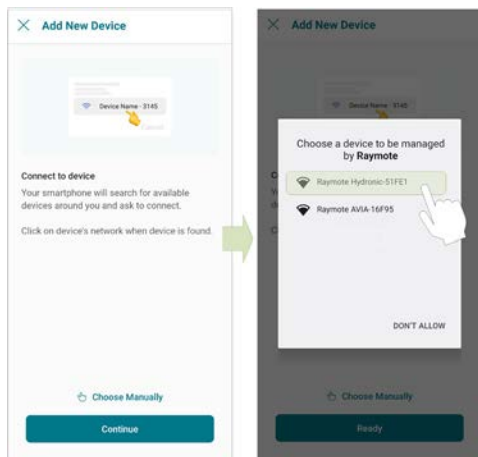

Figure 15. Connect with Android Smart Phone

3. **In iPhone:** Raymote app will start to scan nearby Heaters. If you have multiple units ready to connect, stand closer to the unit you want to connect first.

Press "Join" to select the displayed heater that matches the HOTSPOT identifier, or press cancel to start again the process.

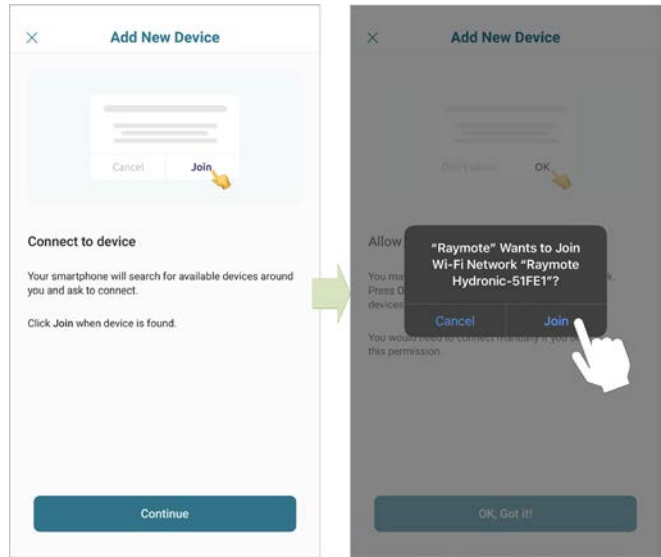

Figure 16. Connecting with iPhone

4. The "Wi-Fi setup" screen will appear. Select or enter the Wi-Fi network you want your unit to be connected to and enter the network password. See **Figure 17**.
5. Press the "Continue" button to proceed with unit connection.

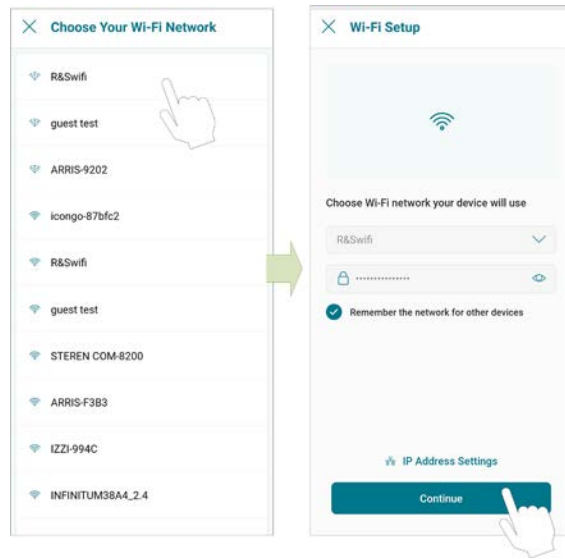

Figure 17. Wi-Fi Setup

IMPORTANT: Raymote Wi-Fi module works with 2.4GHz Wi-Fi signals only.
 Ensure to have a strong signal near the Heater, the Wi-Fi password and to use a 2.4 GHz network.
 (IEEE 802.11, 802.11b/g/n/ax).

- Raymote app will provide the Wi-Fi credentials to your unit. This process may take a few seconds. See **Figure 17**.

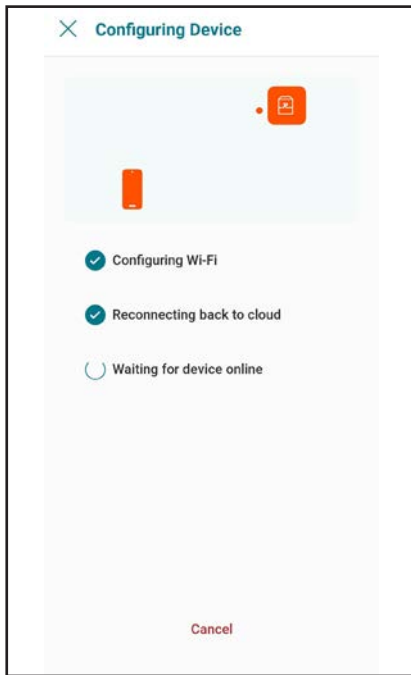

Figure 18. Configuring Device

- "Check your Device" screen will appear. Ensure Wi-Fi signal is available in the area, then press the "Ready" button.

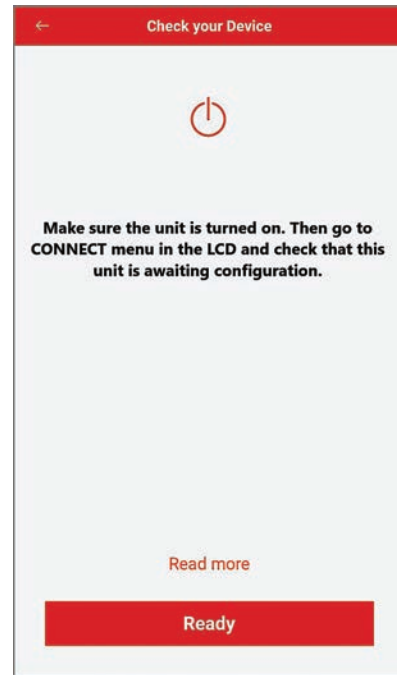

Figure 20. Check your Device

- Continue in page 12 to Boiler Profile setup.

For iPhone 6 and Earlier Versions

- The "Wi-Fi setup" screen will appear. Select or enter the Wi-Fi network you want your unit to be connected to and enter the network password. See **Figure 19**.
- Press the "Continue" button.

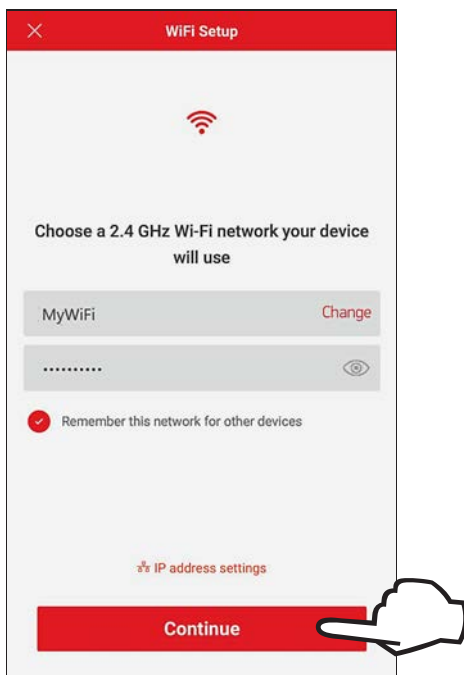

Figure 19. Wi-Fi Setup

NOTE: The first time you use a new phone, the Raymote mobile app will require you grant permission to access data. See **Figure 21**.

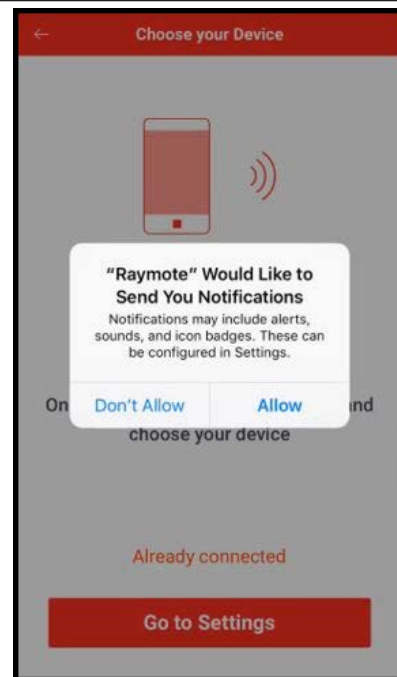

Figure 21. Grant Permission

4. Press the "Go to Settings" button on the "Choose your Device" screen. See **Figure 22**.

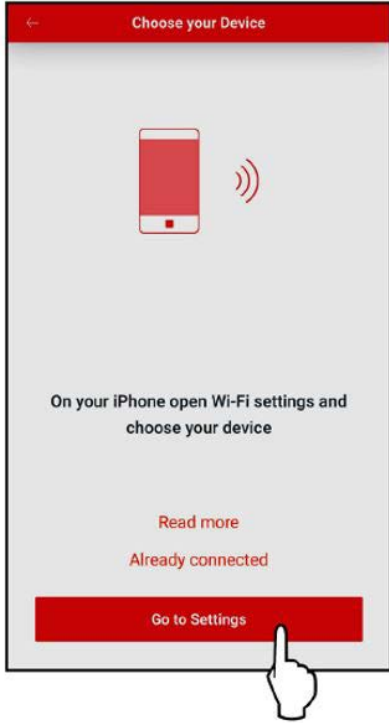

Figure 22. Go to Settings

6. Select the Wi-Fi network on the Settings menu. See **Figure 24**.

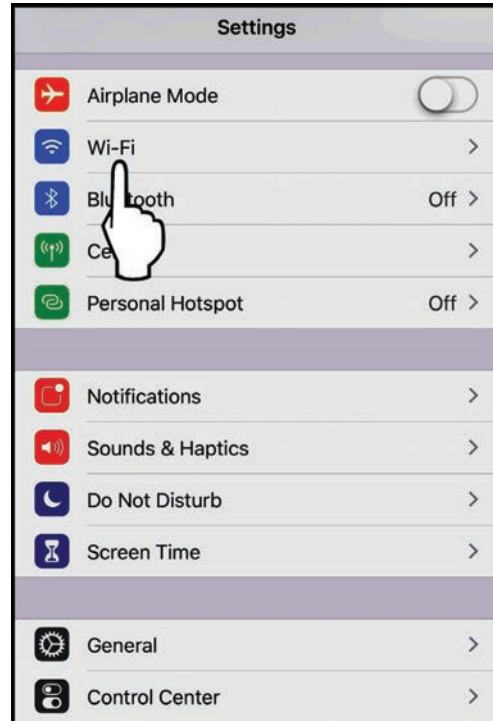

Figure 24. Select Wi-Fi Network

5. On the top left corner of the screen, press the "Settings" button to go the Settings menu. See **Figure 23**.

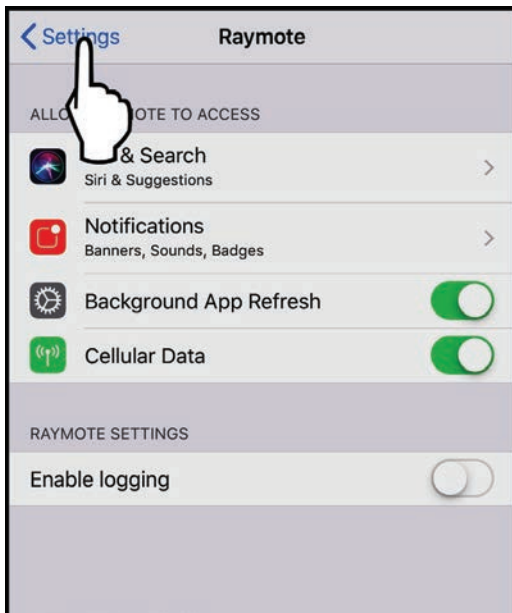

Figure 23. Select the Settings Menu

7. Select the HOTSPOT identifier that matches the unit's Touchscreen as shown in **Figure 25**.



Figure 25. Select the HOTSPOT Identifier

8. A notification tab will confirm that iPhone is now connected to the unit. Press the notification tab or manually go back to the Raymote mobile iPhone app to continue. See **Figure 26**.



Figure 26. Connection Notification

9. The Raymote mobile app will provide the Wi-Fi network credentials to your unit. See **Figure 27**.

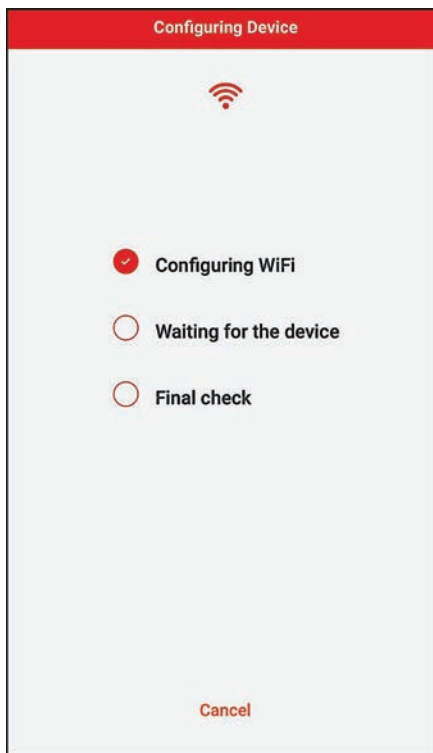

Figure 27. Configuring Device

Boiler Profile Setup

1. Your device is now connected to Wi-Fi. You can change the name of your device here. See **Figure 28**.

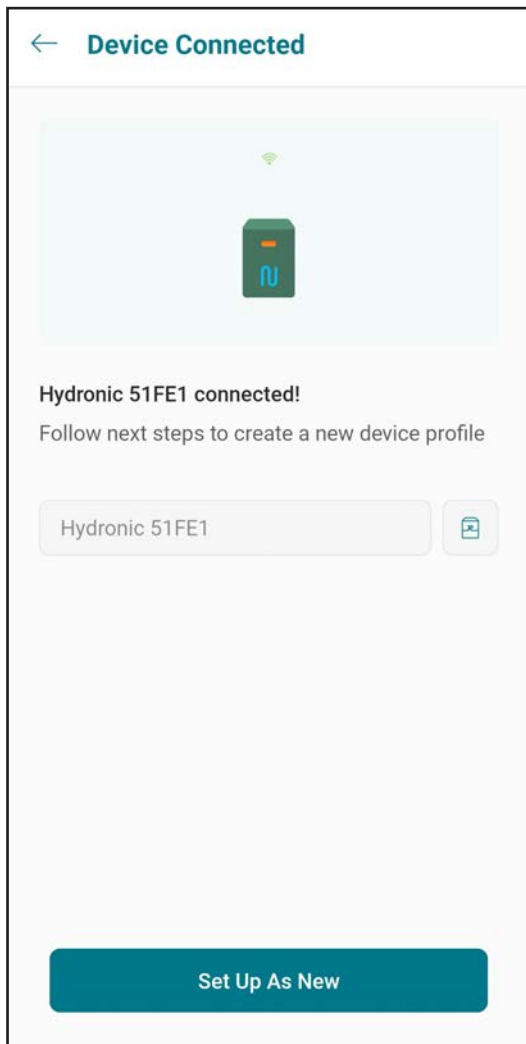

Figure 28. Name Your Unit

2. Press the "Set up as new" button to enter job site and service information. When available, press the "Apply recently used profile" button to use information already used in another unit setup. See **Figure 29**.

NOTE: This information can be updated at anytime from the Raymote mobile app or the web dashboard. It is strongly recommended to make sure this information is completed.

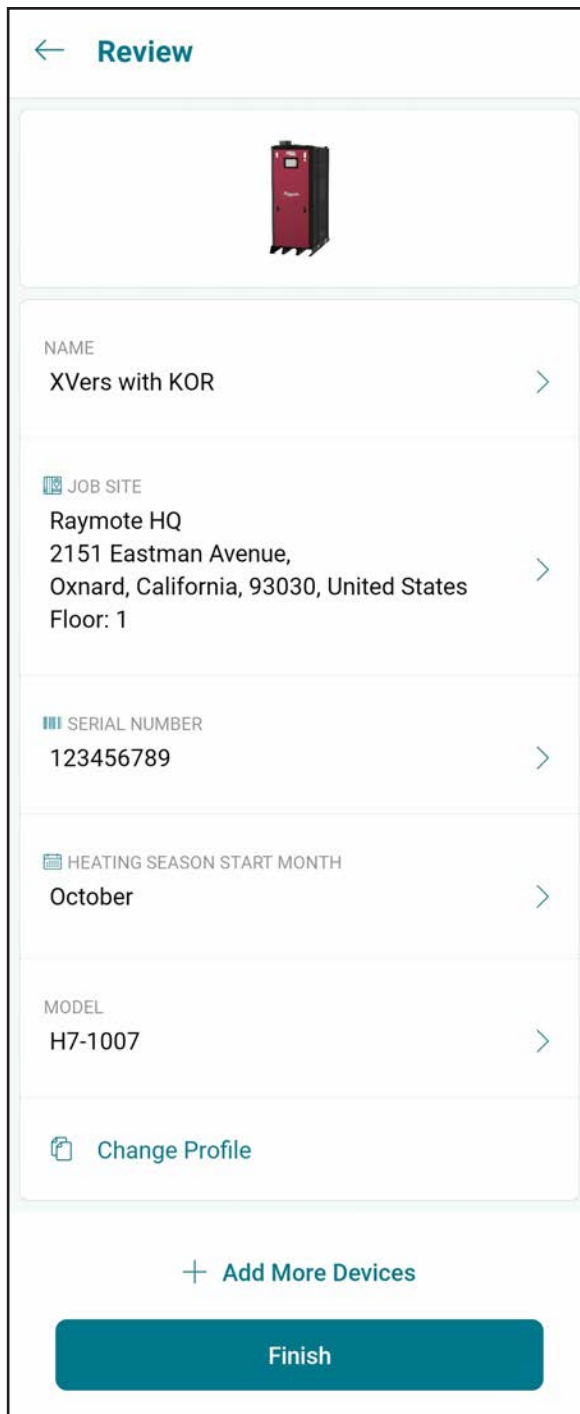

Figure 29. Review Information

NOTE: This information can be added at any time, and it is highly recommended to provide as much detail as possible to facilitate ease of use and customer service.

3. After completing the Raymote configuration, the unit will start broadcasting data to the Raymote cloud.

6. RAYMOTE MOBILE APP



Figure 30. Icon

User and Organization Settings

1. User profile
 - Update your username, email, or password.
 - Edit or delete your Raymote account.

2. Raymote App settings
 - Adjust app preferences for notifications and appearance.
3. Organization Settings
 - Review and Update your Raymote organization settings.
 - Add, edit, or remove Members with access to your Raymote organization.
 - For Raymote client accounts, share access to your Raymote organization with a Contractor with an active Raymote Partner account.

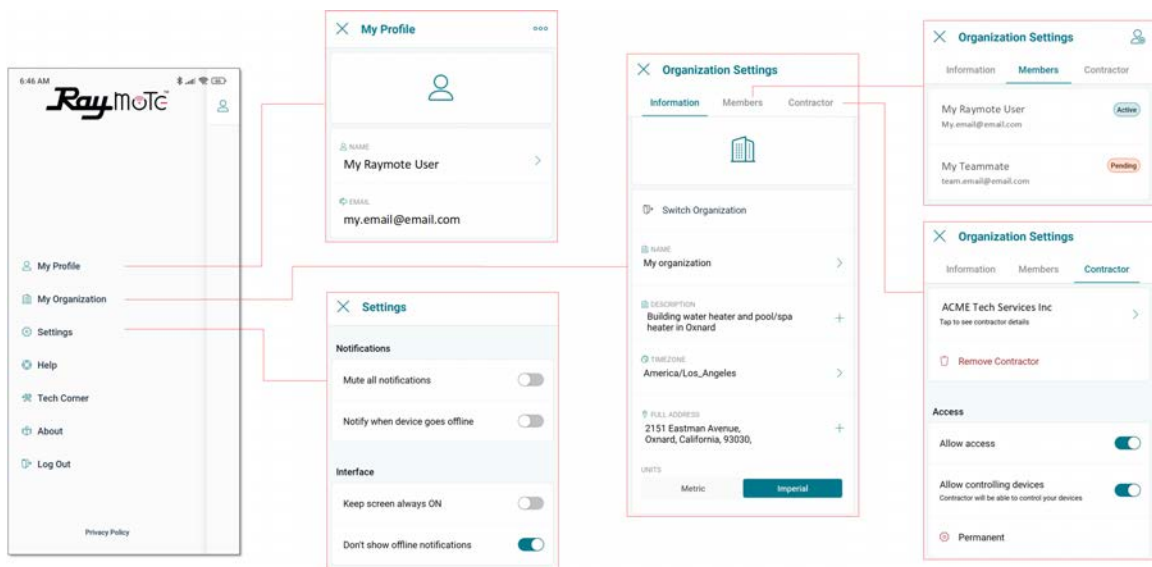

Figure 31. Settings - Client Accounts

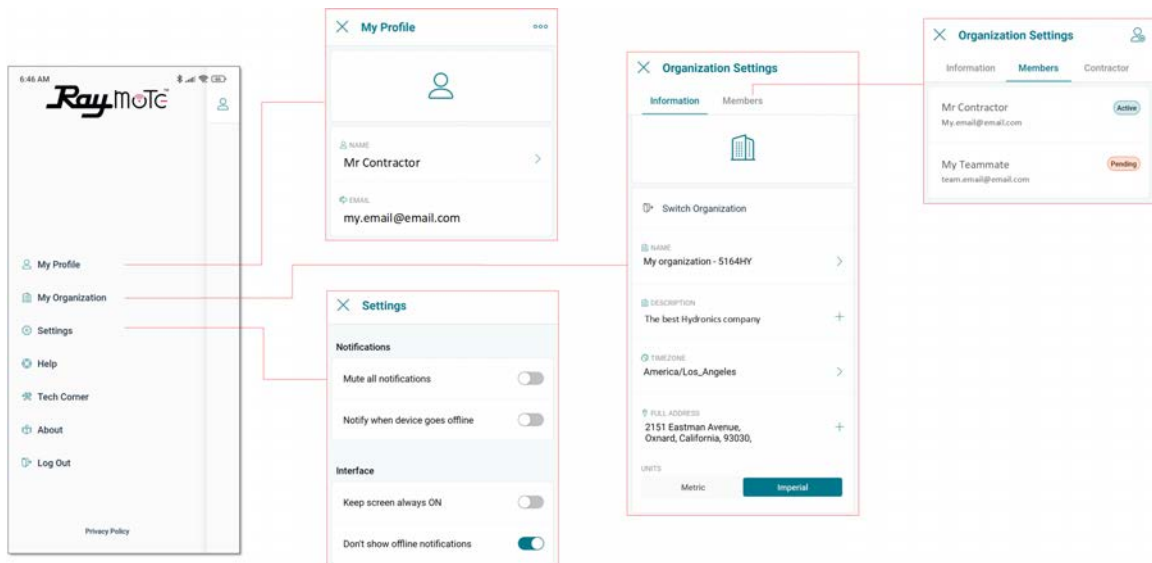

Figure 32. Settings - Partner Accounts

Help and Tech Support

Raymote App provides direct access to technical support for Raypak heaters, service kits, I&O manuals and Raymote topics

1. Raymote Help

- In-App access to Raymote online resources and technical contents.

2. Tech Corner

- In-App access to Raypak Tech Corner collection. You can find here detailed instructions for Raypak products and service kits.

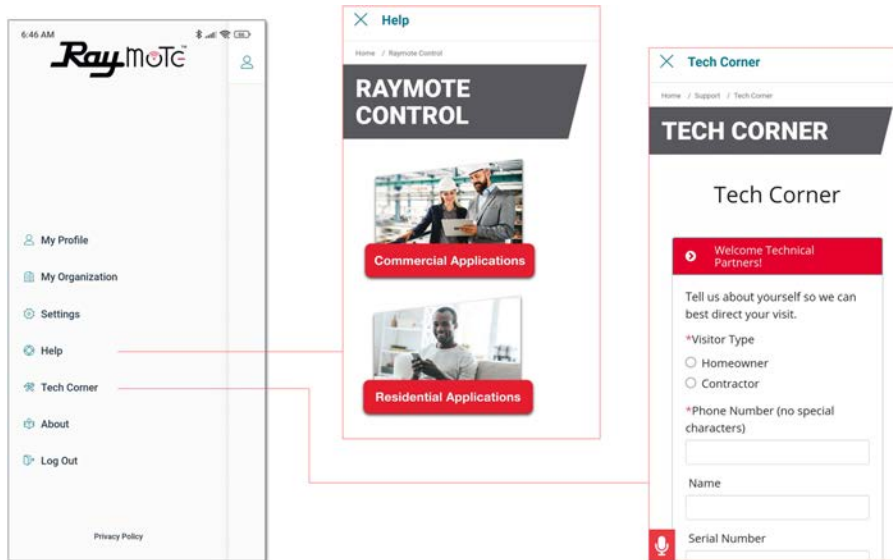

Figure 33. Help and Tech Support

Main View

- The main view of Raymote display a list of the heaters added in to your Raymote Organization.
- Each heater is represented by a tile with its name and an overview of the heater operation parameters.
- Raymote organization list can handle 1 or multiple Commercial and Residential Raypak heaters equipped with Raymote.

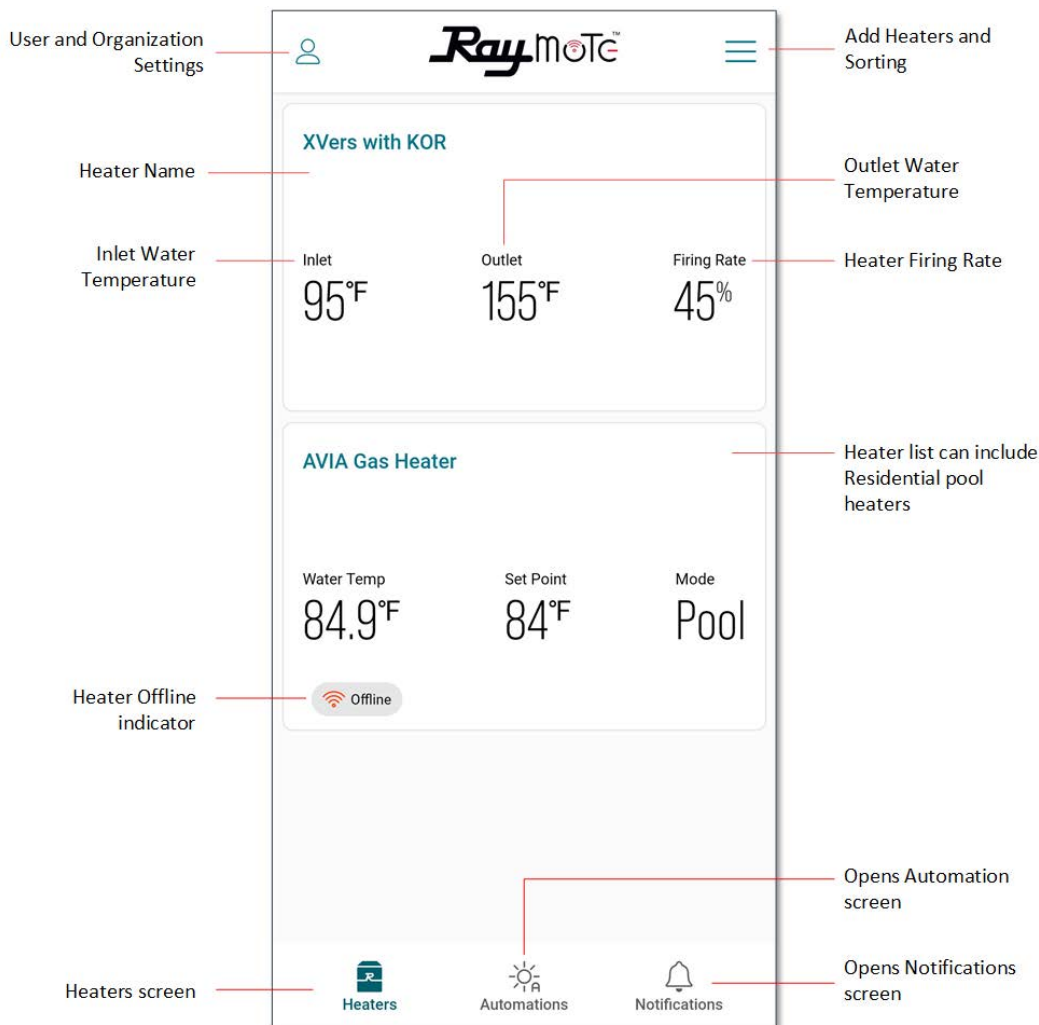

Figure 34. Main View - Heaters List

Heater Name

- Heater name is defined during the Heater connection and setup, but it can be changed anytime from the heater settings.

Inlet Water Temp

- The Inlet water temperature measured by the heater is displayed in this field. Inlet Water Temperature readings are taken from the Inlet of the heat exchanger.

Outlet Water Temp

- The Outlet water temperature measured by the heater is displayed in this field. Outlet Water Temperature readings are taken from the Outlet of the heat exchanger.

Firing Rate

- The Firing Rate indicator displays a real-time rate provided by the Heater. The values displayed varies with the modulation of the heater.

Offline Indicator

- The offline indicator is displayed only when the Heater cannot be detected online.
- Offline status can be cause by a heater disconnected from power, Wi-Fi signal weak or not available, or due to any change in Wi-Fi signal name or password.
- Check the Connectivity Troubleshooting section for details on how to recover or reconnect a heater to Raymote.

Automation

Raymote automation offers the ability to select Boiler parameters and customize a specific condition that could trigger a notification or an action to update a parameter. See **Figure 35** and **Figure 36**.

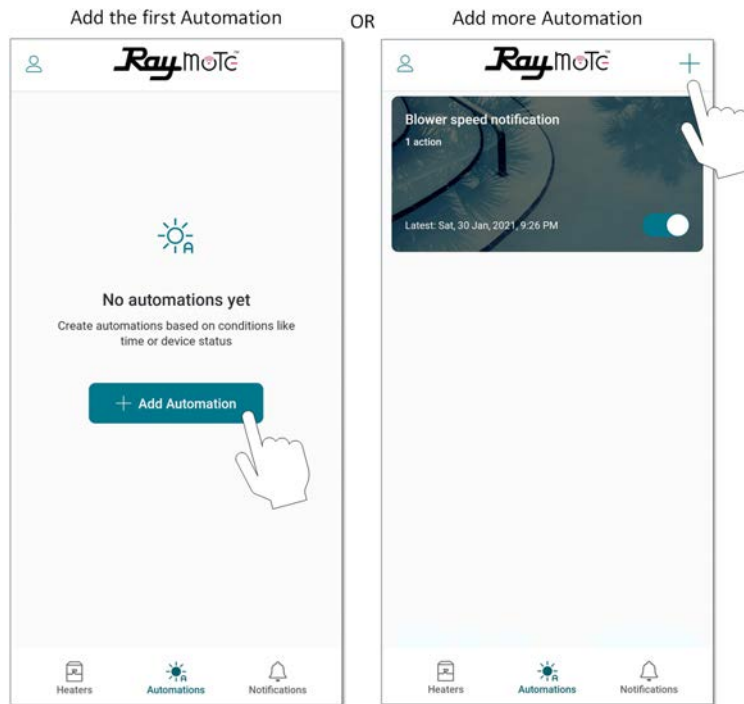

Figure 35. Automation

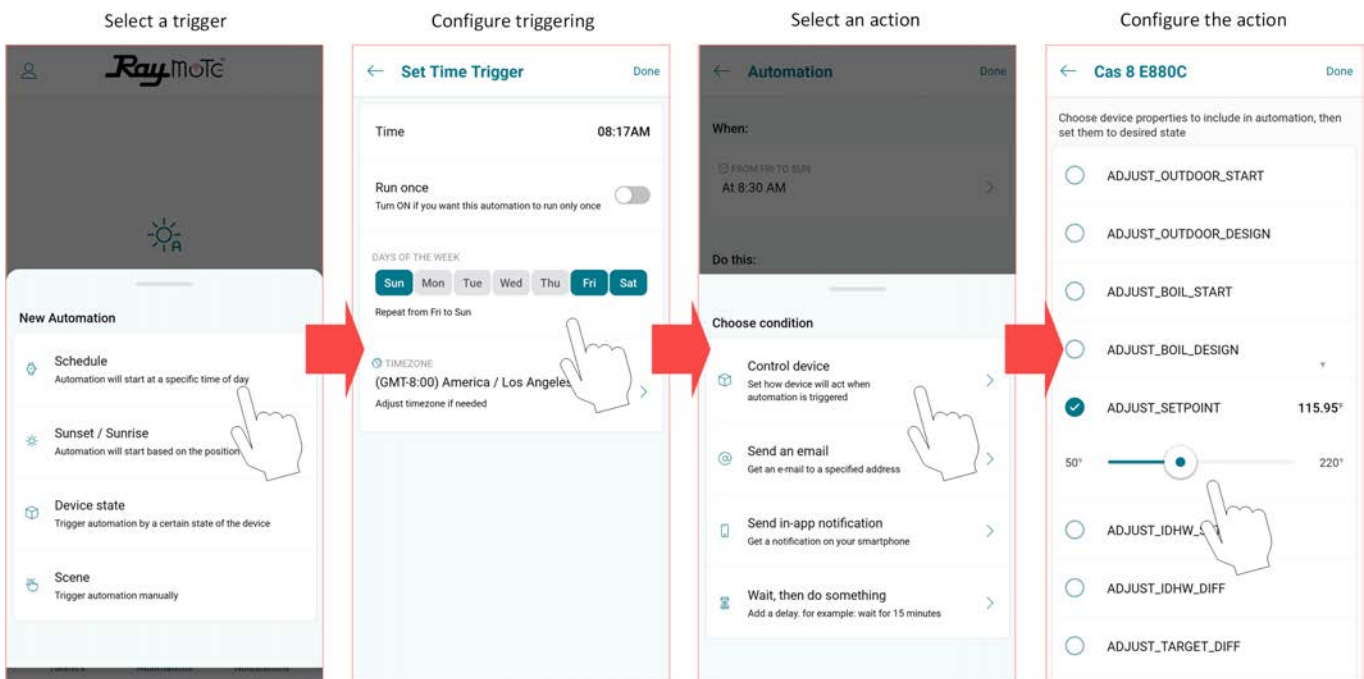

Figure 36. Set New Automation

View Screen

Click in the tile to open Heater control and monitoring views. See **Figure 37**.

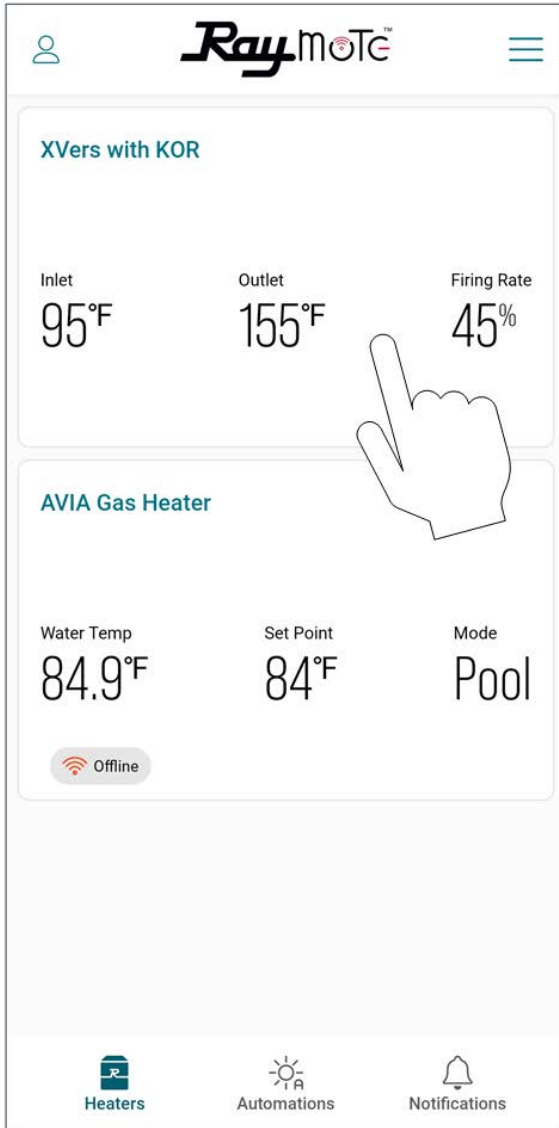

Figure 37. Click to Open View Screen

The View page shows the most important information of the Heater in real time, for monitoring operation and performance.

The View screen of the Raymote mobile app presents unit specific and system related data. See **Figure 38**.

NOTE: Some of the values may not be present in all system configurations. Whenever a value is not applicable to the system configuration, it will be grayed out and disabled. If an optional sensor is not present, the corresponding value will be displayed as dashes.

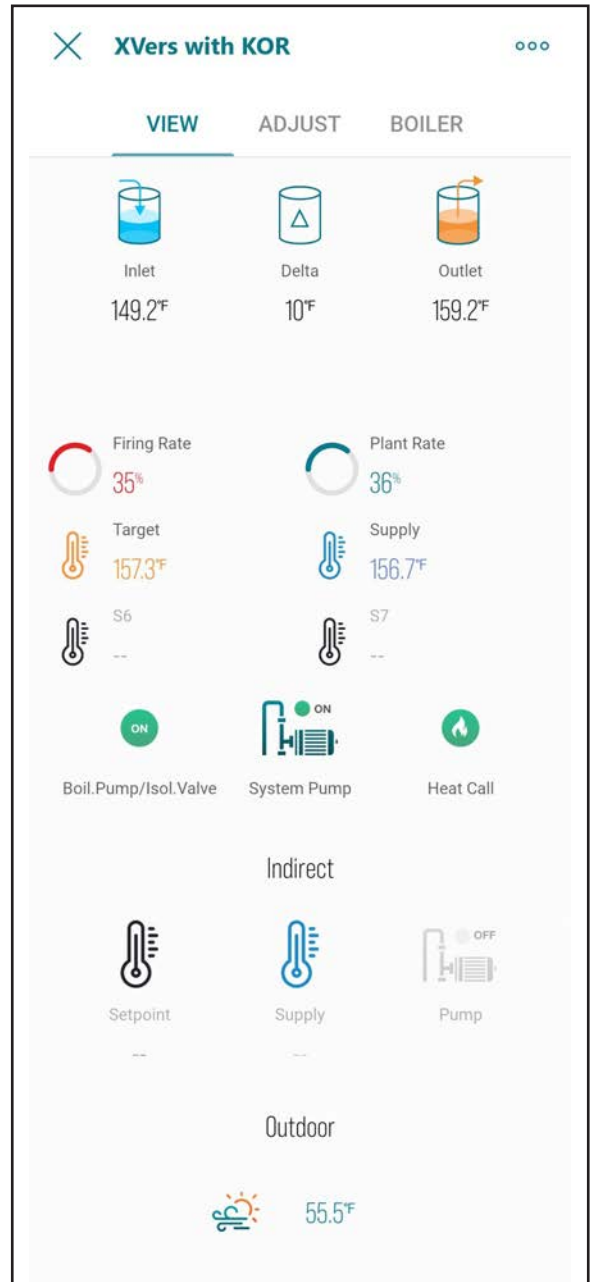

Figure 38. View Screen

Boiler Screen

The Boiler page displays detailed information of the heater. This page can be used to review performance in real time as well as historical data of the heater. The Boiler screen presents specific unit data, but not application data. See **Figure 39**.

NOTE: Some information is not standard on all units, such as Flow, Vent (temperature), and O₂ monitoring.

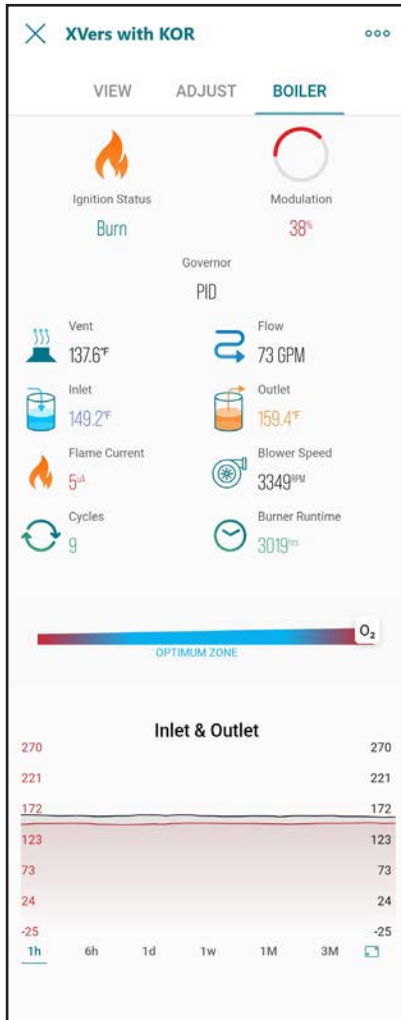

Figure 39. Boiler Screen

Adjust Screen

The Adjust screen includes all available unit controls in the Raymote mobile app. These controls allow users to remotely change limited settings of the boiler.

⚠ WARNING: Only authorized users have access to remotely control the boiler, do not provide credentials to unauthorized users. Control attempts will modify settings on the unit and impact operation of the unit.

Some controls are application dependent and may not be available on all units. When a control or set of controls are not available, these will be grayed out.

Raymote controls will reflect the actual status of the value on the local unit. When a change is applied to any control item, the position of the slider will reflect the confirmation value of the setting. See **Figure 40**.

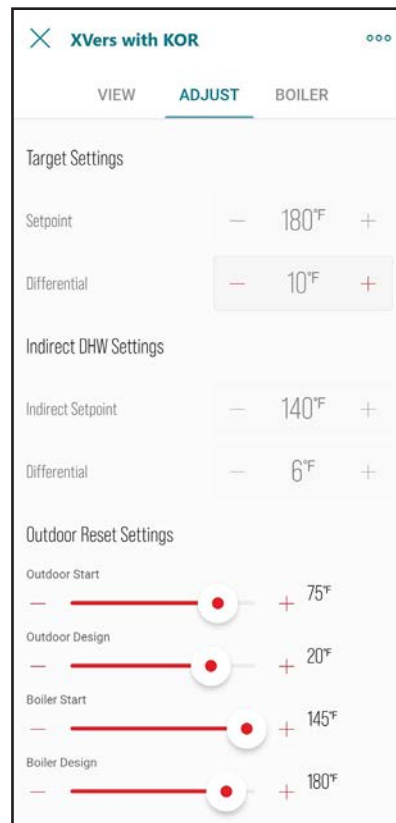

Figure 40. Adjust Screen

7. WEB DASHBOARD

Visit <http://raymote.raypak.com> to get access to the Raymote web dashboard on your PC.

The Raymote web dashboard allows access to:

- Long-term monitoring of Raypak boilers, pool and water heaters
- Create organizations (group installations and job sites)
- Assign or remove users
- Adjust rules and permissions

Device Dashboard

Device view displays the most relevant unit operation information, inputs, and outputs. Data time range can be changed by clicking the predefined ranges or by custom range. See **Figure 41**.

Devices Timeline

This section lists all the relevant events associated with the unit operation, warnings and diagnostic information. Warning events can be marked as resolved and notes can be added to record corrective actions or relevant information. See **Figure 42**.

Device Info

The user can review or edit unit information, location and contact information. This information can be updated anytime. See **Figure 43**.

NOTE: This information can be added at any time, and it is highly recommended to provide as much detail as possible to facilitate ease of use and customer service.

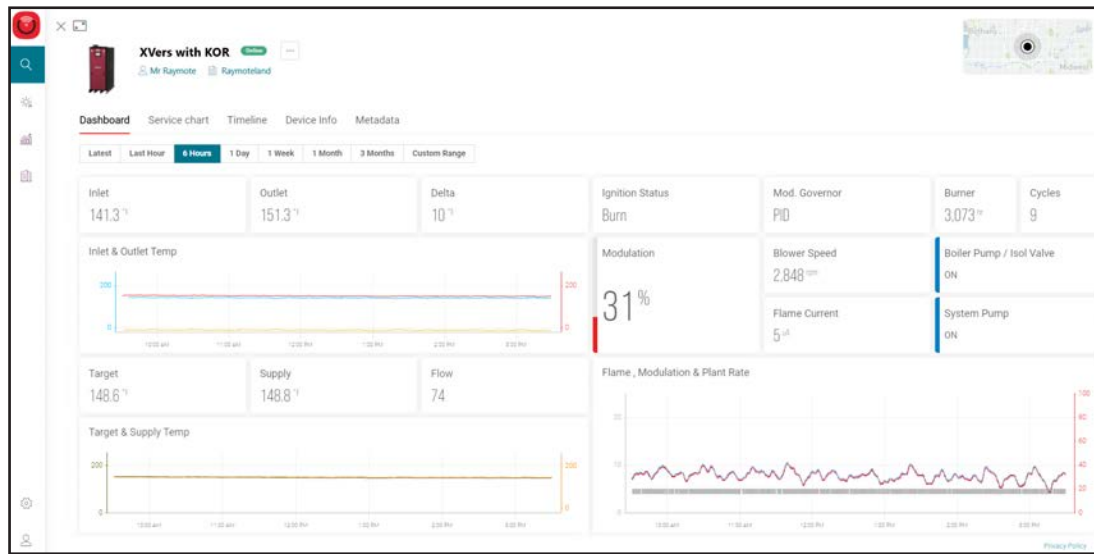

Figure 41. Web Dashboard

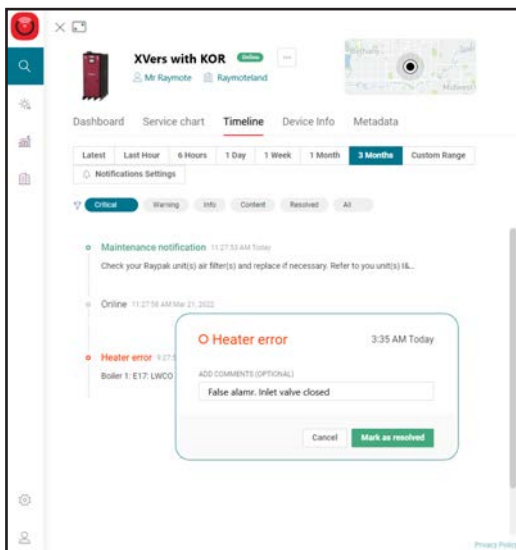

Figure 42. Web Dashboard - Timeline

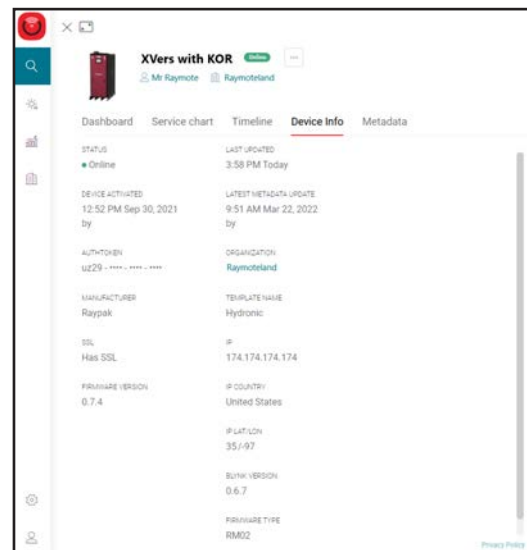

Figure 43. Web Dashboard - Device Info

Search Function



Figure 44. Icon

The search function allows Raymote users to find devices, organizations, sites and other users that pertain to the same network. Multiple metadata fields are used to narrow the search operation, serial number, names, email

address, name of the unit, anything that could be used to narrow the search options.

The Raymote search page is by default the first welcome screen, see **Figure 45**.

To access the search function:

1. Click on magnifier icon located on side bar
2. Select the search desired search category see **Figure 46**.
3. You can search for any data field across devices, organizations, and users. Simply start typing.

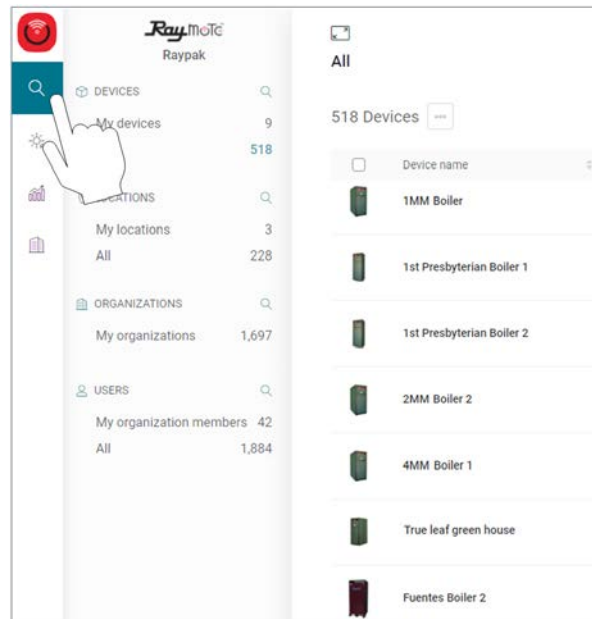

Figure 45. Accessing Search Page

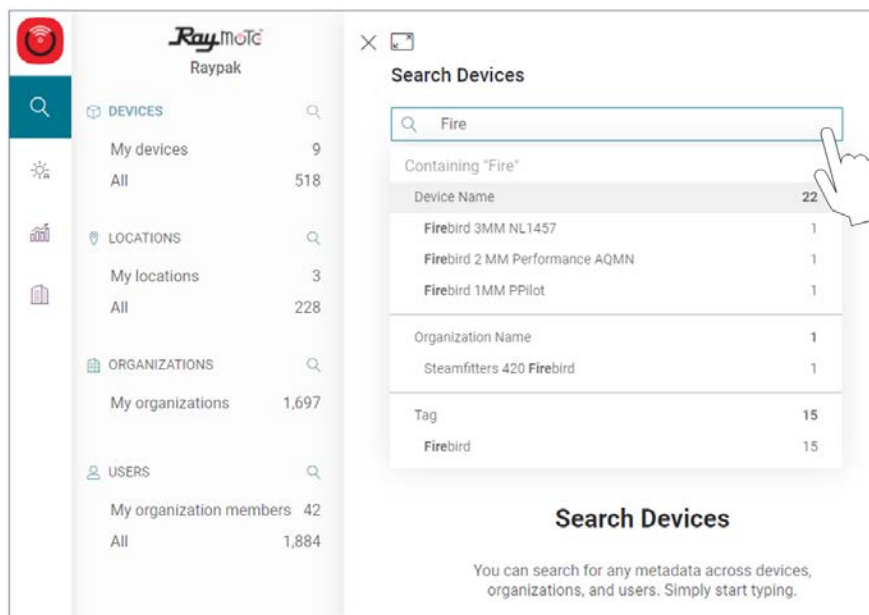

Figure 46. Search Functions

How to Create an Organization

Organizations are used to define owners and responsible personnel to monitor installed Raypak units.

An organization is a customer, who can have one or multiple sub-organizations, which can have one or multiple job sites. An example of an organization could be a hotel chain, who can have multiple regions (sub-organizations) and these could have multiple locations (job sites).

In order to create an Organization, go to the dashboard menu, see **Figure 47**, and click on the last menu item called “Organizations” and click on “Create New Organization”, see **Figure 48**.



Figure 47. Dashboard Menu

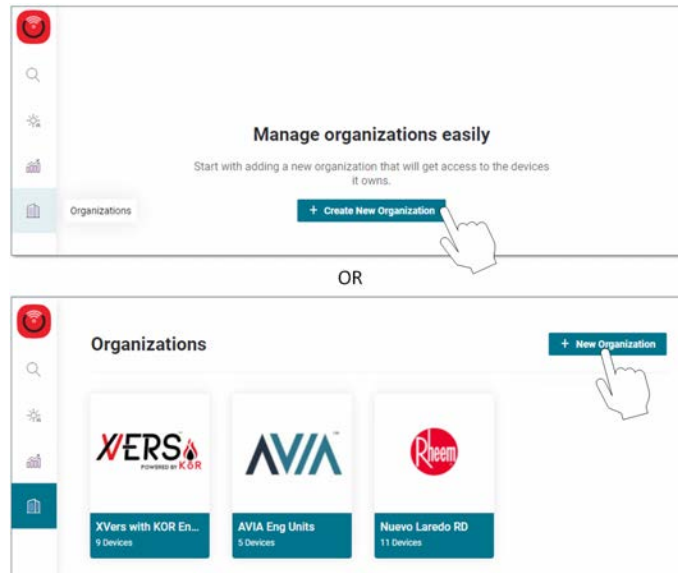

Figure 48. Create New Organization

A new window will appear to fill the new Organization information.

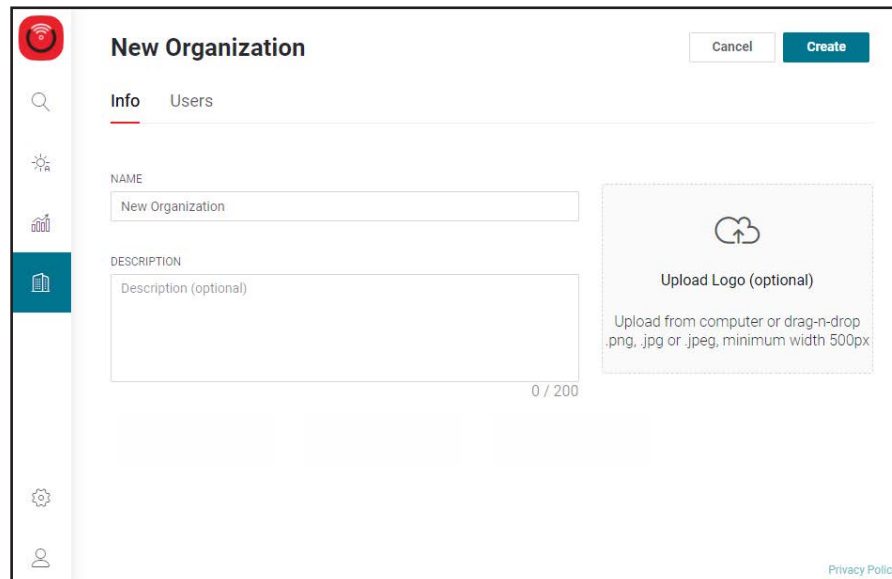

Figure 49. New Organization, Info Tab

In the “Info” tab fill the following fields, see **Figure 49**:

Name – Specify the Company name for the Organization.

Description – Include a full description for the Organization to be created.

Logo – A logo can be included to be displayed on the Dashboard. If no logo is specified, by default the Raymote logo is used for the organization.

New Organization can’t create Sub-Organizations – This radio button indicates if sub-organizations may or not include sub-organizations.

In the “Users” tab, see **Figure 50**, you can send invitations for administrators and users for the organization.

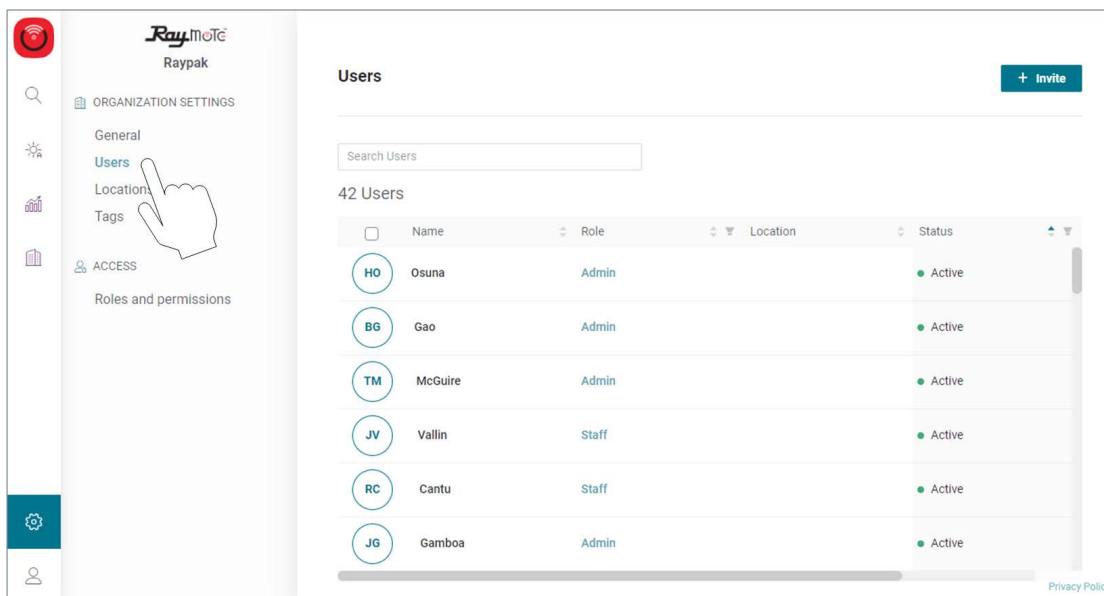

Figure 50. New Organization, User Tab

In order to send an invitation, you must fill the 3 fields:

User name – Indicate the name for the user.

Email address – Indicate the e-mail to send the invitation, as well as contact mail for user.

Role – Choose between Admin, Staff or User. The differences are described below:

- Admin: Has full access to users, devices, sub organizations and locations.

- Staff: Has limited access, but still can edit users, devices and locations.
- User: Is the typical end user. Limited to display data of owned devices and users.

After all initial users have been defined, click on “Create” button (top right window).

How to Create a Location

Desktop Instructions

After creating an Organization, if required, Locations for job sites can be created to improve organization:

1. Click on the Settings menu, see **Figure 51**, and the “Organization Settings” menu will appear.



Figure 51. Settings Menu Icon

2. Select “Locations” option from Organization Settings menu. See number 2 in **Figure 51**.
3. Click on “+ Add Location” button on the screen. See number 3 in **Figure 51**.
4. Enter the Job Site Name and Address and click “Done” button. See number 5 in **Figure 51**.

Locations can be used in any unit added under the same organization.

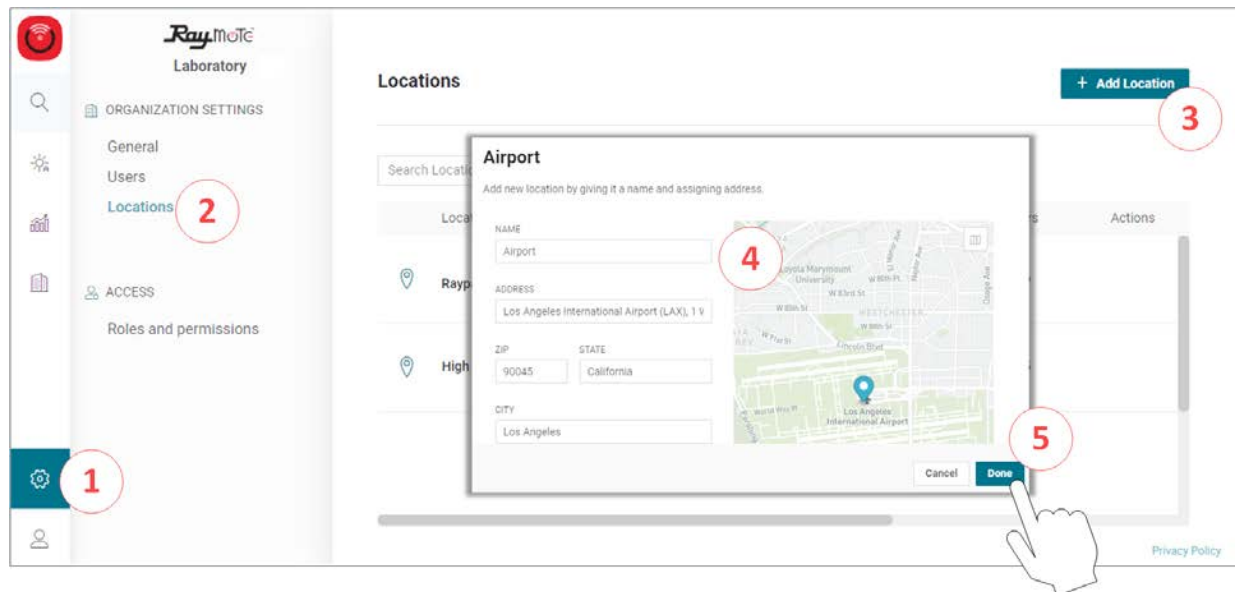

Figure 52. Organization Settings Menu

Set a Job Site from mobile

Job Site location can be created on the phone at the time of connecting a unit, or can be done later from unit settings:

1. From Boiler main view, click in the 3-dots icon (...) on top right corner. See **Figure 53**.
2. Select "Job Site" option.

3. Click on "+ Create New Location".

4. Provide a job site name and an address or use the "Set on Map" option.

Now the Job Site is added, any unit that is registered under this organization can be tied to this Job Site.

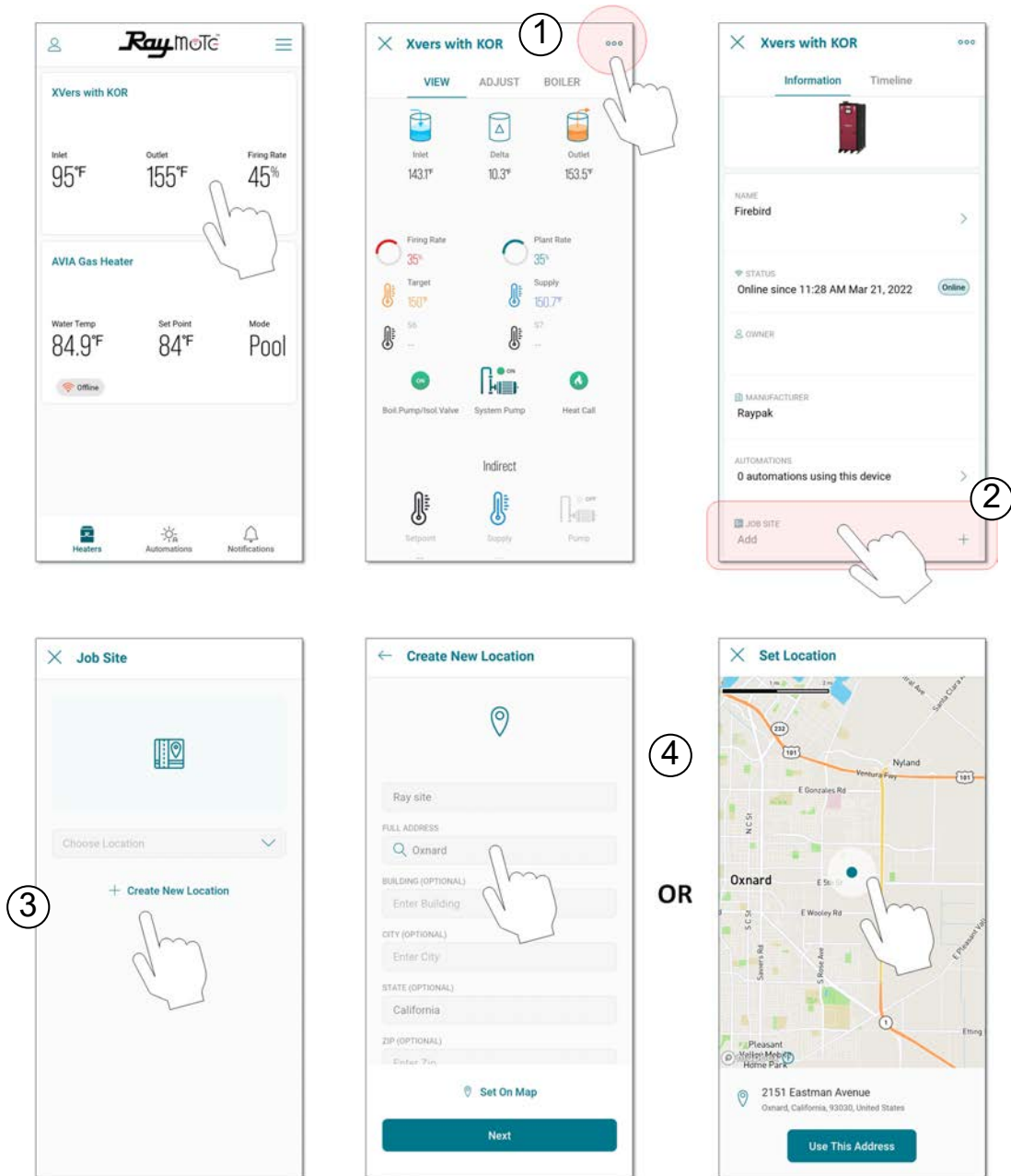

Figure 53. New Location From App

Analytics

To see analytics from a specific organization, click on the “Analytics” button on the menu, see **Figure 54**, and the Dashboard will update with the analytics information of the current selected organization. See **Figure 55**.

The dashboard will display the analytics information by location.



Figure 54. Select Analytics Button

The analytics are displayed by location, which can be displayed by the specified time frame (below the Location name). See **Figure 56** and **Figure 57**. The information includes the details on bar graphs for the following parameters:

- Total number of units
- Number of Online/Offline units
- Critical Events
- Total Cycles (all units)
- Total Runtime in hours (all units)
- Events by name (Online/Offline/Errors)
- Device locations (displayed on map)
- Online/Offline timing graphs per unit
- Effective heat time in hours, by unit
- Total cycles by unit
- Total runtime by unit

All this information can be used to provide an easy guide of how the plant distribution is behaving, considering workloads, and even to monitor for service.



Figure 55. Analytics Information

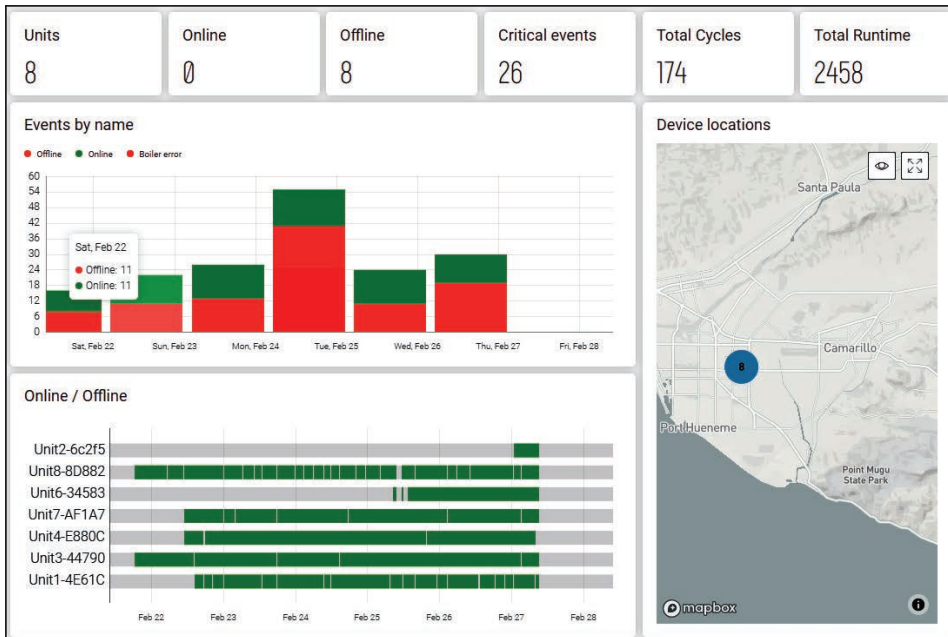

Figure 56. Bar Graph Analytics 1

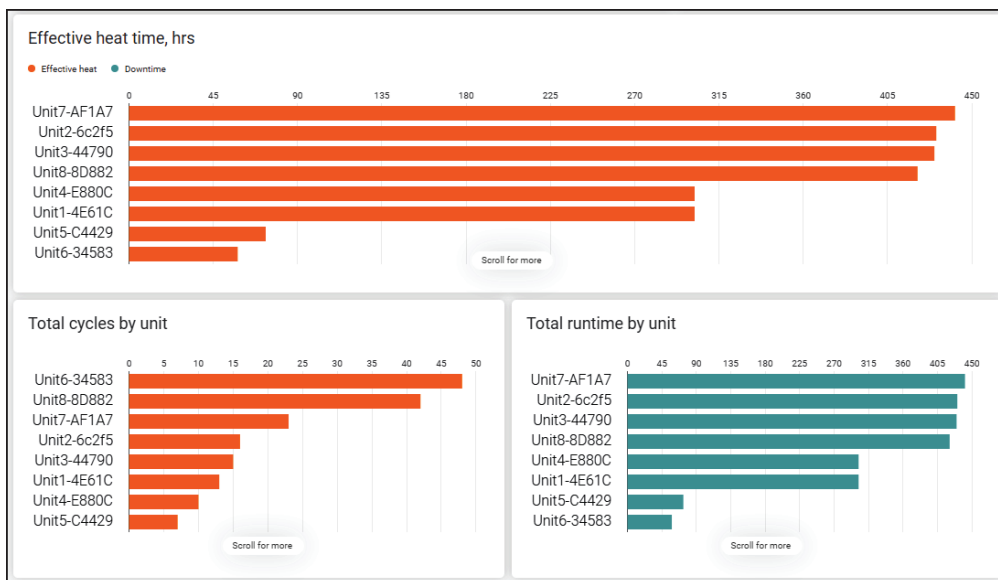

Figure 57. Bar Graph Analytics 2

Update Boiler Data on Existing Devices

Metadata of a device is the most descriptive information that would help to make sure all Raymote functions and experience is accessible. The Proper device setup will help to improve service, identification, and analysis of the products within the network. It is strongly recommended to complete all the Device Setup Metadata, however the most important fields are Serial Number, Model, Site Contact, Service Contact, and Job Site.

The Device information can be added during or after provisioning the unit, it can be provided over the web dashboard or mobile phone.

Providing SITE CONTACT information will ensure that early notifications, proactive maintenance reminders, are sent to the right person. Typically, the building manager or site administrator that have access to boiler room is assigned in the field.

The SERVICE PROVIDER is the Raypak sales partner or approved contractor. This person is the staff member in charge of monitoring and maintaining the optimum operation of the unit.

The JOB SITE defines the location of the unit; this assignation allows installers to associate and group devices into a specific customer site. Once a Job Site location is created or already exist, this becomes a grouping option for multiple units that share the same location (refer to "How to Create a Location" on page 25).

Boiler Data from Web Dashboard

Using Raymote desktop application, after selecting the unit:

1. Select “Metadata” from the top menu. See **Figure 58**.

2. The Metadata menu will display.
3. Scroll the mouse over any field and click “Edit” button to change its information.

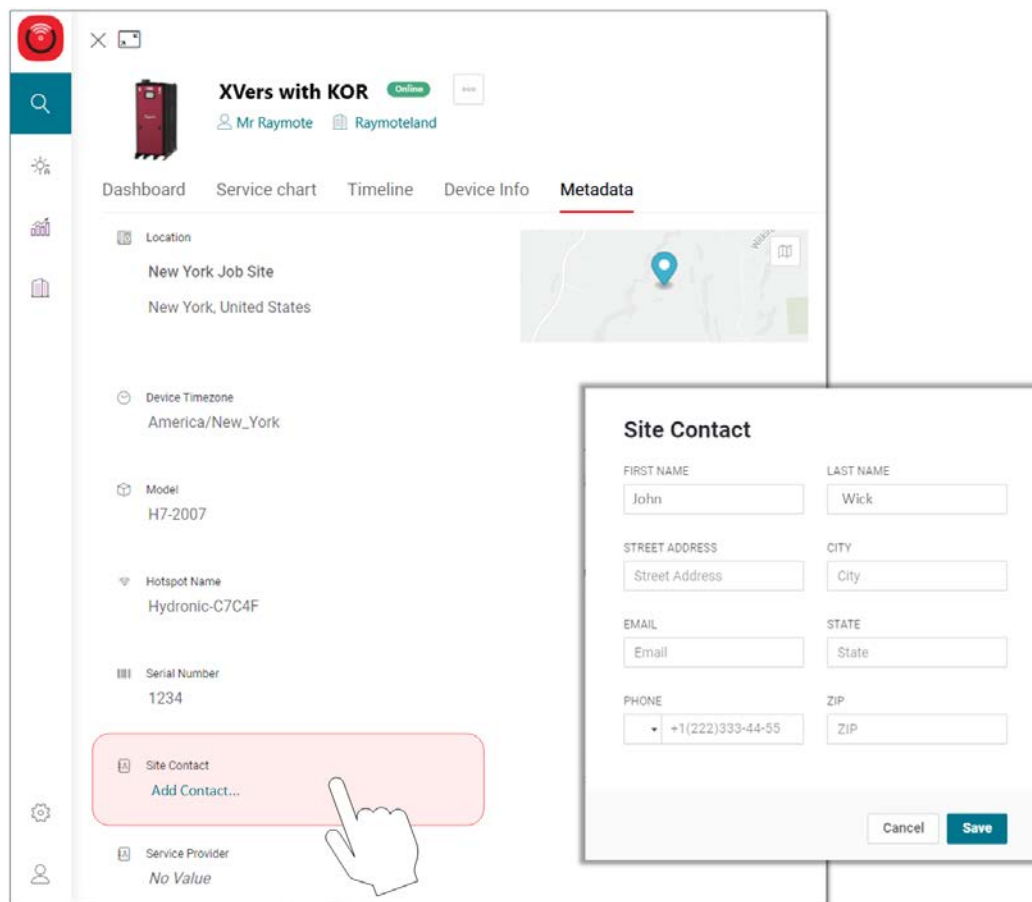

Figure 58. Select Metadata

Boiler Data from Mobile App

Using the Raymote mobile application, after selecting the unit, click on the “Menu” icon on top right corner “...”, and

the screen will be shown to update the fields. Click on any field to update it. See **Figure 59**.

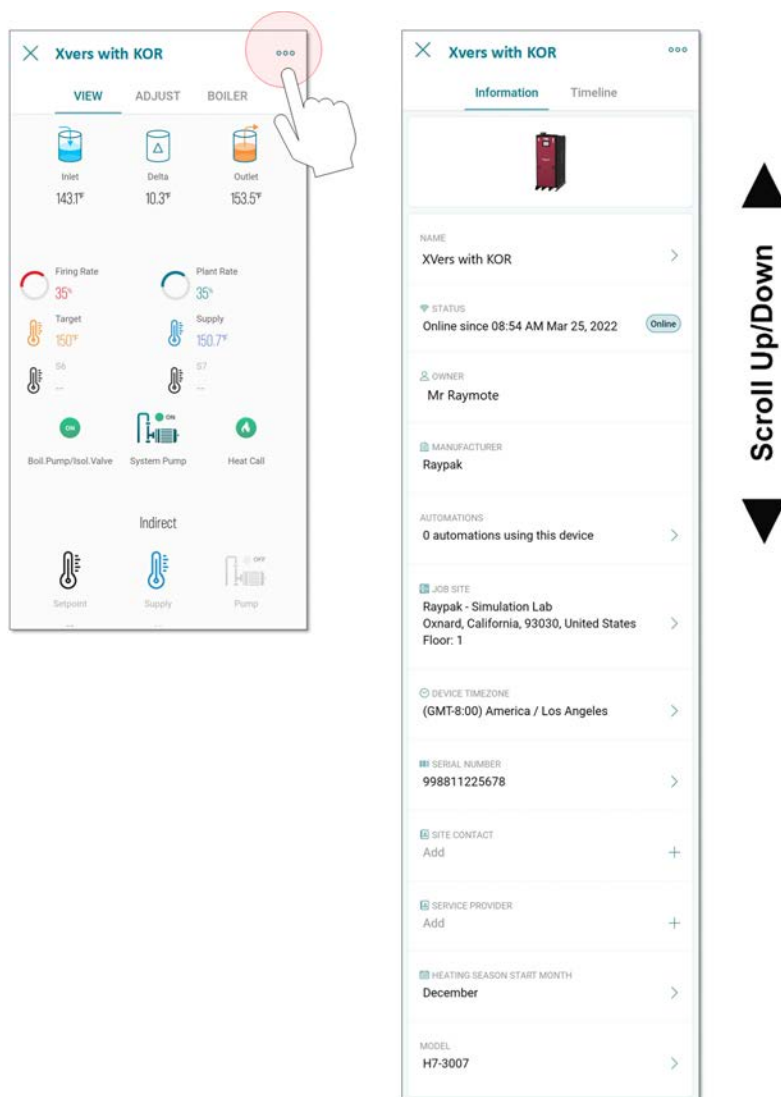

Figure 59. Boiler Data Update from App

Transfer Users and Devices

Transfer Users

To transfer users from one organization to another, follow the next steps:

1. Place the cursor on top of the “Raymote” logo on the menu.
2. Select the origin organization where the user is currently in.
3. Click on the “Settings” option (gear icon) located at the bottom of the left bar and select “Users” on the top menu. See **Figure 60**.
4. Click on the “...” menu on the right of the user that wants to be transferred, and click on “Transfer user”. See **Figure 61**.
5. The “Transfer user” window will appear, type in the Destination Organization Administrator e-mail. See **Figure 62**.
6. After typing a valid administrator organization e-mail, an optional box will appear on the window “Transfer with all devices owned by XXX”. Check it if desired. Click on “Continue transfer”. See **Figure 63**.
7. After transfer is complete, a pop-up window will indicate the user has been transferred to the new organization. See **Figure 64**.

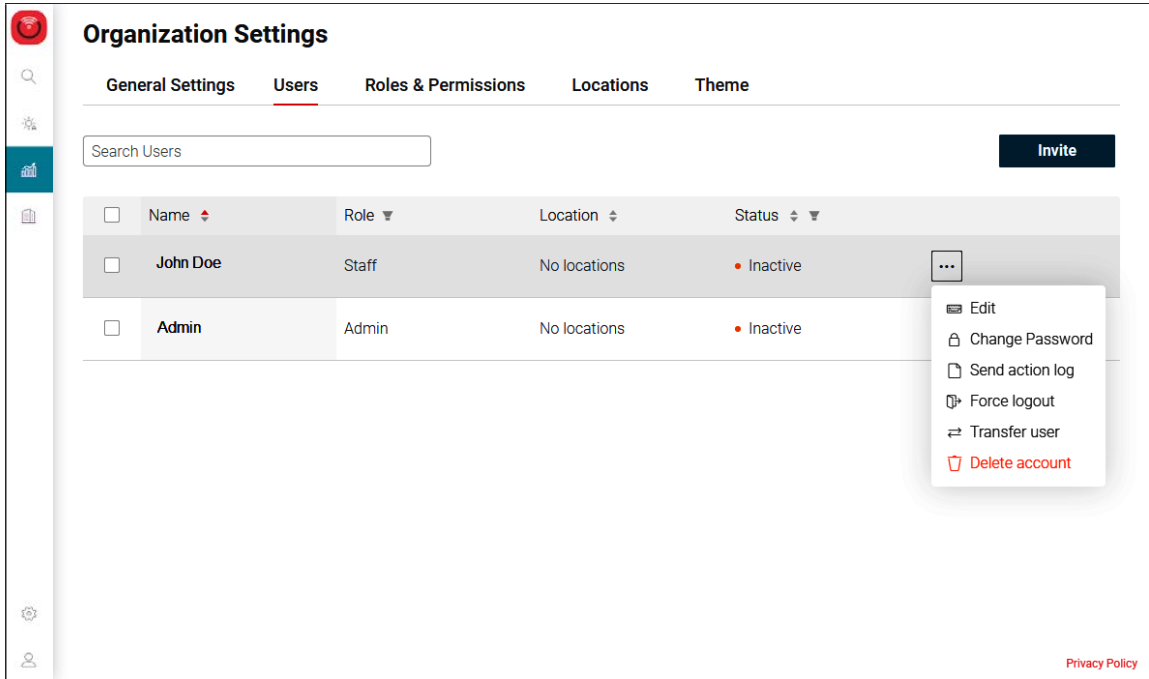

Figure 60. User Setting Menu

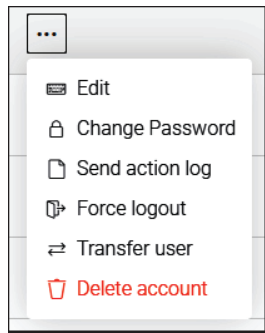

Figure 61. Transfer User Option

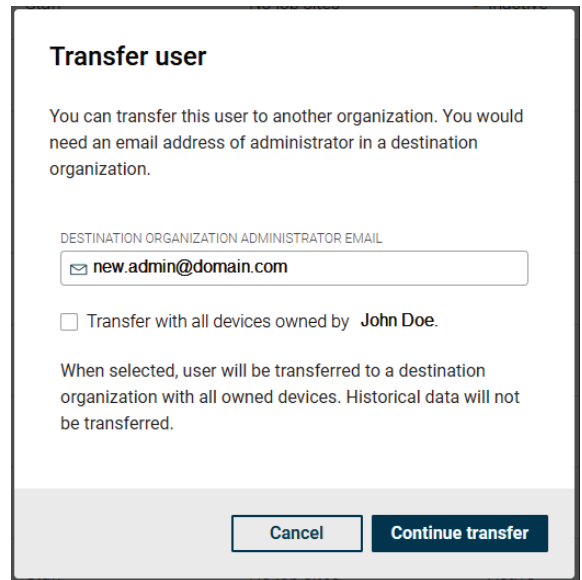

Figure 63. Continue Transfer

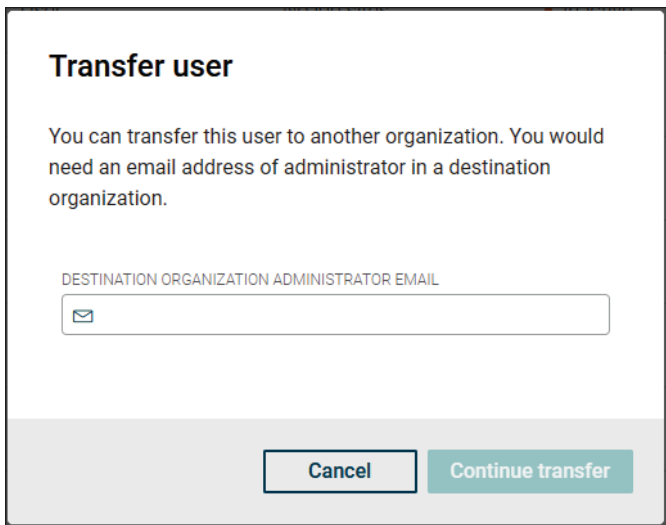

Figure 62. Transfer User - Destination Organization

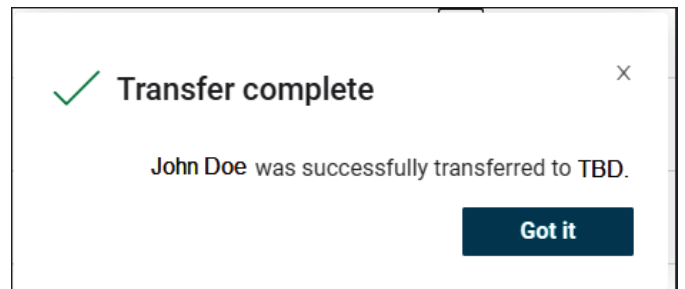

Figure 64. Transfer Status Confirmed

Transfer Devices

To transfer devices from one organization to another, follow the next steps:

1. Place the cursor on top of the “Raymote” logo on the menu.
2. Select the origin organization where the device is currently in.
3. Select the unit to be transferred.
4. Click on the “...” button on the top right menu and select “Transfer”. See **Figure 65**.
5. The “Transfer device ownership” window will appear, type the New Device Owner’s e-mail. Click on “Continue transfer” when filled. See **Figure 66**.
6. After transfer is complete, a pop-up window will indicate the unit has been transferred to the new owner at the desired organization. See **Figure 67**.

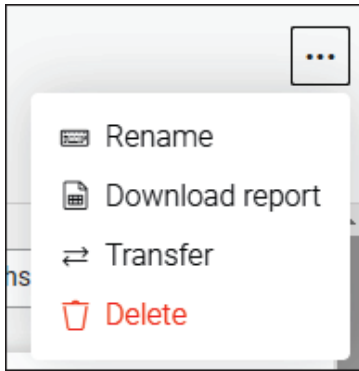

Figure 65. Transferring Device Option

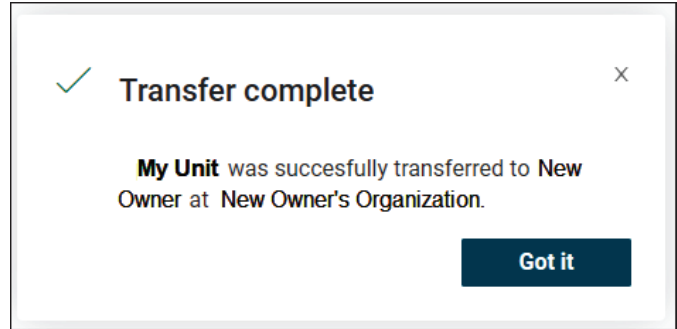

Figure 67. Completed Device Transfer

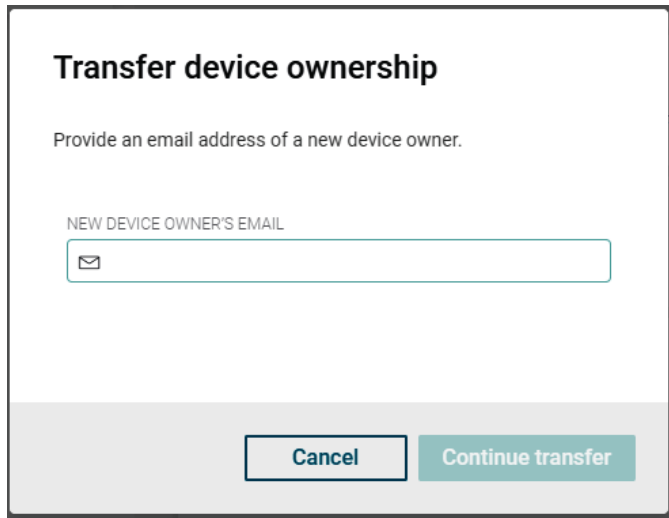

Figure 66. Transferring Device Ownership

Download Reports

To download reports from Raymote, follow the next steps:

1. Place the cursor on top of the “Raymote” logo on the menu.
2. Select the organization where the Unit under analysis belongs.
3. Select the unit to be analyzed.
4. Click on the “...” button on the top right menu. And select “Download Report”. See **Figure 68**.
5. The “Generate report” window will appear and you can select the time range for report data the signals to include in the report (all by default) and if you would like to include events data on a separate file, or if you would like to share this information to somebody else, to send a link via e-mail. See **Figure 69**.
6. If “> Advanced settings” option is selected, timestamp format can be selected, as well as time zone correction and if data aggregation is desired.
7. After “Generate report” button is pressed, a pop-up message will appear indicating when the report is ready to download. See **Figure 70**.
8. If “Download” button is pressed, a .zip file will be downloaded including the selected data. The downloaded information will include a metadata file and the information downloaded in a comma-separated value format (csv). See **Figure 71**.

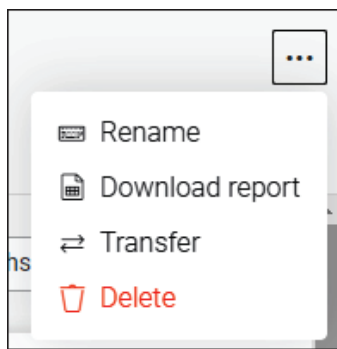

Figure 68. Download Report Option

Generate Report

Get a complete report in .CSV format. Once generated, you can download it. You can optionally send a link to the generated file to the e-mail address.

CHOOSE TIME RANGE FOR REPORT DATA

LIST OF DATASTREAMS

Include events data

SEND TO E-MAIL

Send a link to e-mail

Advanced Settings

DATA AGGREGATION

TIMEZONE CORRECTION

DATE AND TIME FORMAT

10/29/19 05:16:56 PM

Figure 69. Generate Report and Advance Options

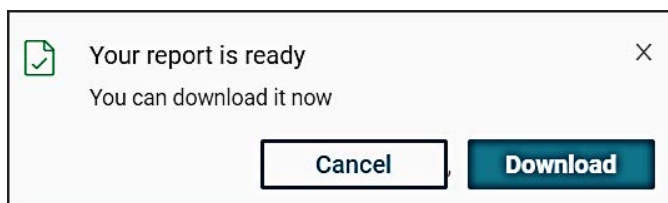

Figure 70. Download Access

Name	Type	Compressed size	Size
metadata.json	JSON File	1 KB	1 KB
Unit6-34583_547_data.csv	Microsoft Excel Comma Separated Values File	172 KB	1,862 KB

Figure 71. Zip File Data

Service Charts Tutorial

To view service charts using Raymote, follow the next steps:

1. Select the unit to be analyzed.
2. Select "Service Chart" from the top menu. See **Figure 72**.
3. On the left panel under "Data streams" type key words to display and select up to 6 signals to be include on the graph. See **Figure 73**.

4. Move the cursor over the graph area to display signals values of a given time. See **Figure 73**.
5. Click-and-hold a certain area on the graph to zoom in on a specific time frame.
6. Graph will update in the specified time frame. A "Reset zoom" button will become available on top of the graph to go back. See **Figure 73**.



Figure 72. Service Chart and Signal Selection

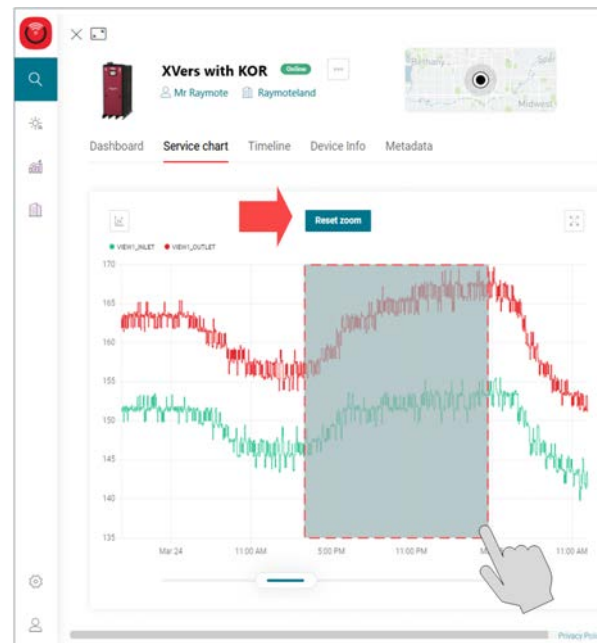
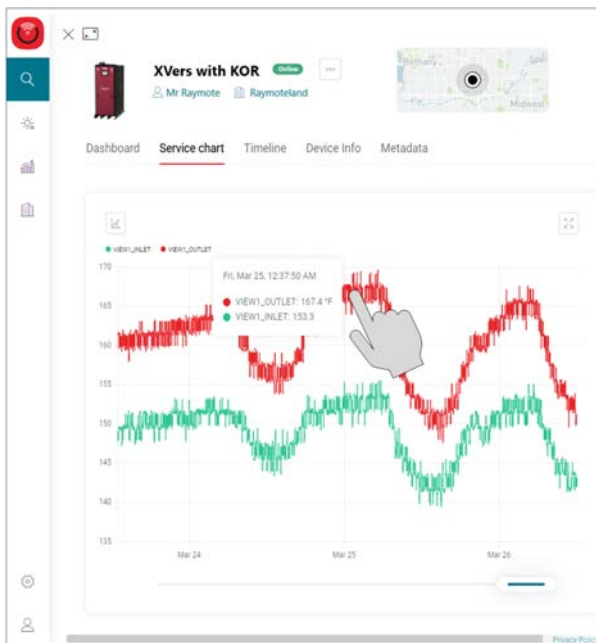

Figure 73. Data Streams

7. Please note that certain time frames the unit might be offline or disconnected from network, such time frames are grayed out on graph. See **Figure 74**.
8. If you want to change the displayed time frame, on the lower part of the graph there is a bar specifying the time frame to be graphed. See **Figure 75**.
9. Slide the bar to specify other time frame and the graph will be automatically updated.

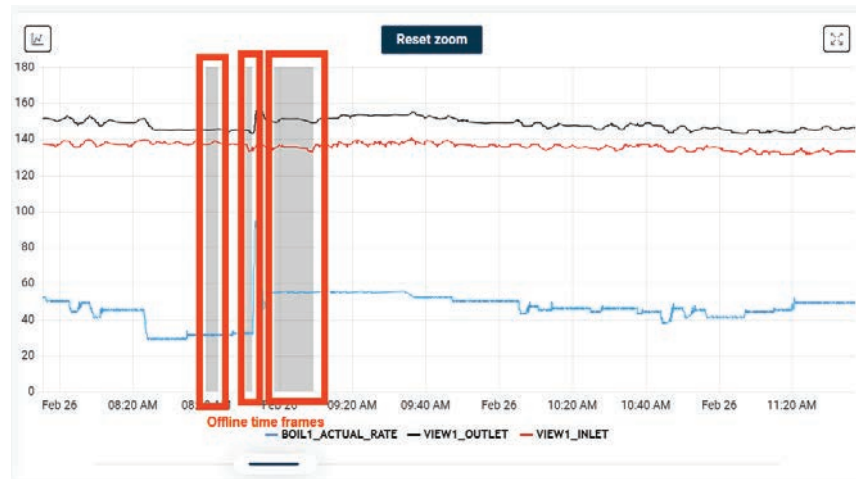

Figure 74. Temporal Discontinuity Illustration

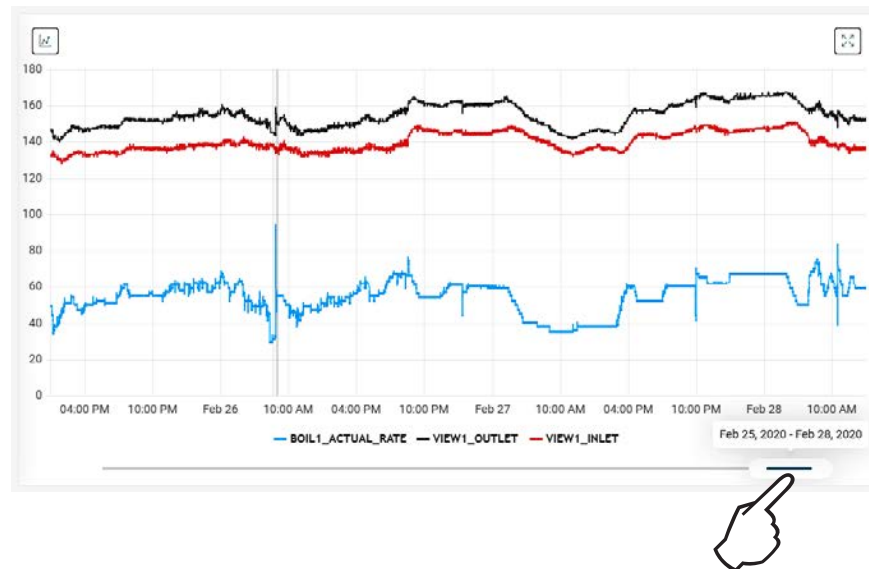

Figure 75. Time Frame Adjustment

Change to Other Organization

If your Raymote organization has 1 or more sub organizations, you can switch to other organization by using the Organization tree or search function.

1. Open the main menu by clicking the top left icon. See **Figure 76**.
2. On the main menu, click on the "Organization" option. See **Figure 77**.
3. In "Organization Settings" page, select "Switch organization" option.
4. "Choose organization" screen will be displayed and it will show all the available organizations. Navigate the sub Organization list or use the search tool to locate desired organization. See **Figure 78**.

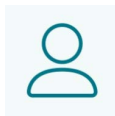

Figure 76. User Menu

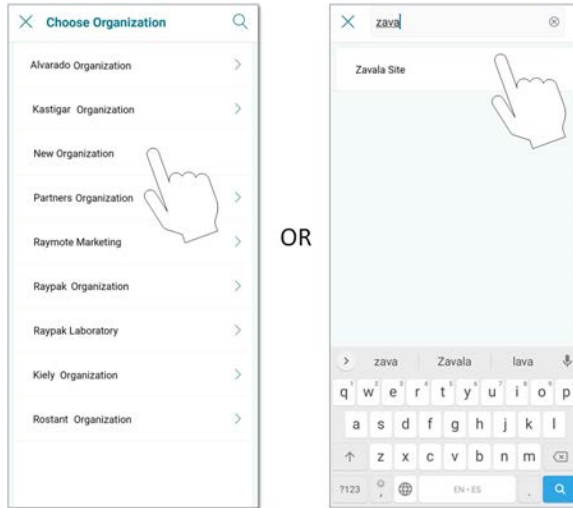

Figure 78. Choose Organization

Change Devices Sorting and Adding New Devices

1. Click on the top right icon to visualize Devices list options. See **Figure 79**.
2. Devices list options menu will appear, where you can choose sorting or add a new device to the organization. See **Figure 80**.



Figure 79. Icon 2



Figure 80. Add New Device and Sorting

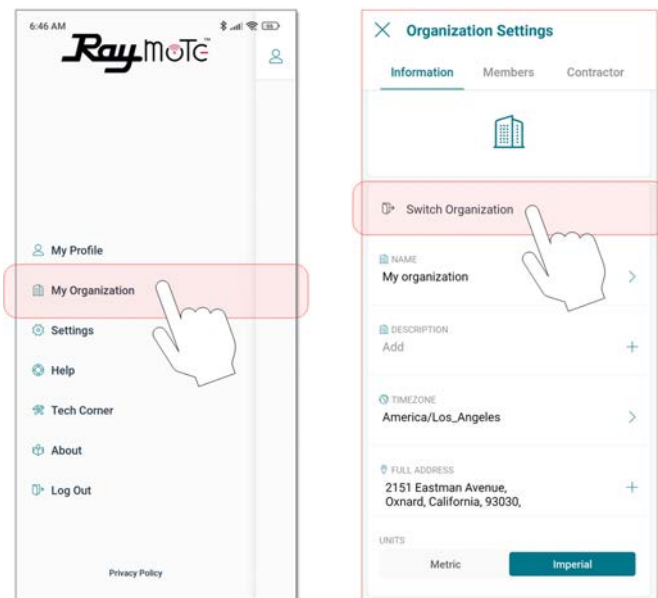

Figure 77. Switch Organization

8. ROLES AND PERMISSION

At the bottom left corner of the Account Settings screen, press the user icon to access the Users screen. The user registering the units or initializing a site is assigned with administrator role credentials. Each role has different permissions; such as inviting users, assigning permissions, registering new units, and enabling different notification levels. Raymote user registration starts when a formal invitation is received from another Raymote user or administrator. See **Figure 81**.

The permission privileges can be personalized for each user. See **Figure 82**.

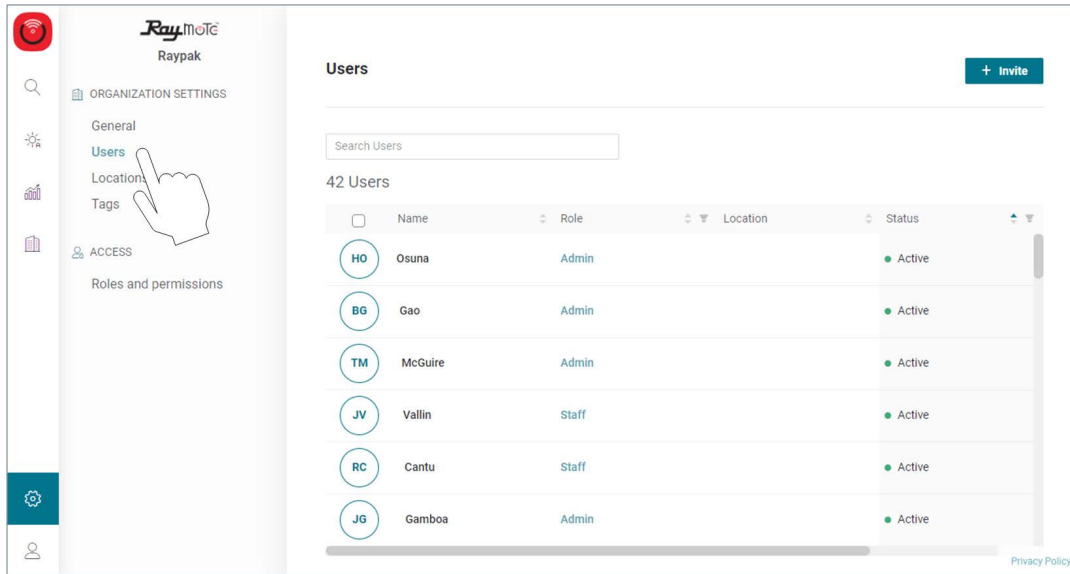

Figure 81. Account Settings - Users Screen

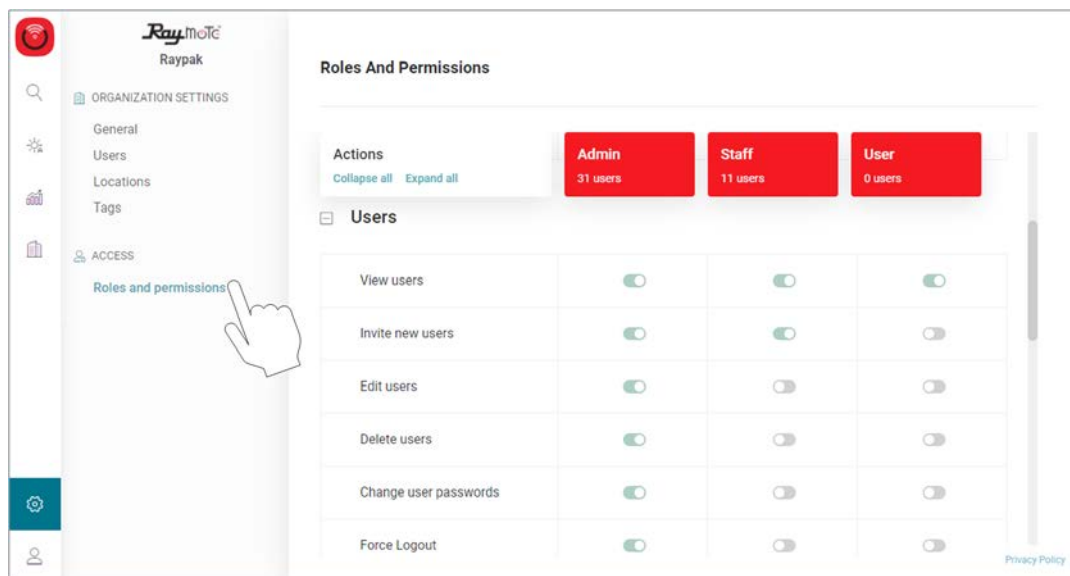

Figure 82. Account Settings - Roles and Permission Screen

9. TROUBLESHOOTING

- With your cellphone check that Wi-Fi signal is available next to the unit. Ensure that your Wi-Fi network meets these specifications:
 - Supported Networks - Wi-Fi **2.4GHz** (802.11 b/g/n).
 - Password encryptions - WEP, WPA, WPA2.
 - Wi-Fi signal icon of 2 bars (-60dB) or better at heater location.

Signal [dB]	Quality
≥ -30	Excellent
-50	Very Good
-60	Good
-70	Limited
-80	Bad
-90	Unreliable

Figure 83. Wi-Fi Signal

- Use the built-in Wi-Fi network options in your cellphone or use a Wi-Fi network scanner app like **Fing Network Scanner** for iPhone or **Wi-Fi Analyzer** for Android smart phones, to check signal strength.

If you are having troubles connecting your Heater to the Raymote app, try these common solutions:

- Check that Wi-Fi signal name and password are correct.
- In case of a change, proceed to Reset Wi-Fi credential from Heater Touchscreen and reconnect the heater with Raymote app.



Figure 84. Reset Wi-Fi Credential

- Check that your Wi-Fi signal strength is strong enough to reach the heater.
 - Reduce distance between Wi-Fi router and the heater.
 - Add a Wi-Fi range extender to cover heater zone or enable a new Wi-Fi access point.

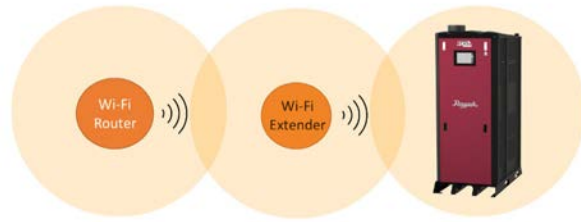

Figure 85. Wi-Fi Extender

- Update Raymote app to the latest version.



Figure 86. Update Application

- Power-cycle your heater and restart Raymote app.



Figure 87. Restart Raymote

- Check the settings on your router or Wi-Fi access point.
 - If needed, enable a dedicated 2.4 GHz network. 5GHz signals are not compatible with Raymote.
 - When applicable, ensure to have the permissions from IT or Building manager.
 - Check if MAC address whitelisting is required
 - Check if Static IP is required.



Figure 88. Wi-Fi Access Point Settings

If you are experiencing connectivity issues with your unit and Raymote, check the following items:

Problem	Solution
Boiler Status is "Offline". See Figure 89 .	Check if your boiler touchscreen is powered on. Turn on the unit. Check if Wi-Fi signal is available. If not, enable Wi-Fi signal and make sure the unit is within Wi-Fi signal range.

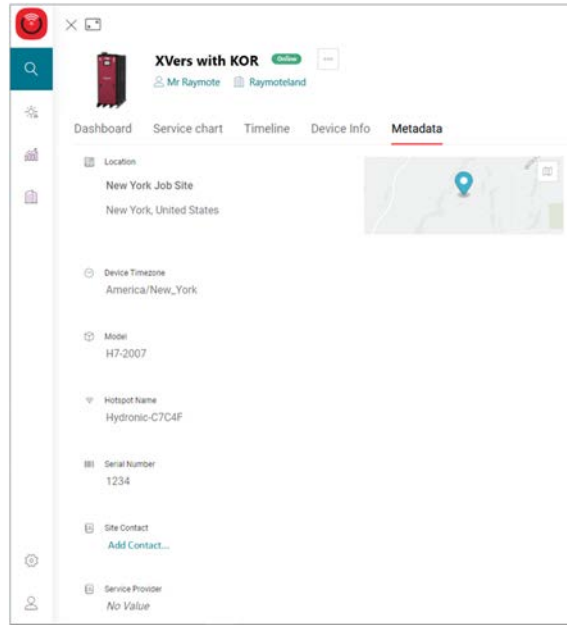

Figure 89. Web Dashboard - Device Info

Problem	Solution
Wi-Fi State displays Error. See Figure 90 .	<p>Make sure that Wi-Fi signal reception is available near the unit. A Wi-Fi extender can be added to improve the signal.</p> <p>Check if Wi-Fi signal name (SSID) matches with the SSID displayed on the touchscreen. If the SSID was changed, update this information. Reset Raymote credentials by pressing the "Reset" button on the Wi-Fi page. Perform the Provisioning steps. See Section 5.</p> <p>Check if Wi-Fi password was changed recently. If password was changed, update this information. Reset Raymote credentials by pressing the "Reset" button in the Wi-Fi page. Perform the provisioning steps. See Section 5.</p>

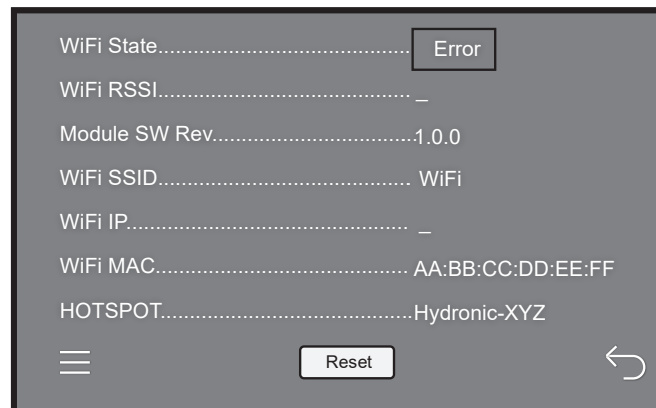

Figure 90. Wi-Fi State - Error

Problem	Solution
<p>Raymote mobile app or dashboard data do not match boiler touchscreen data. See Figure 91.</p>	<p>Make sure that unit is online. Make sure that unit, Touchscreen and Wi-Fi source are turned On. Check web dashboard or Raymote mobile app unit status.</p> <p>Wi-Fi signal is weak. Use any Wi-Fi enabled device to check RSSI next to the unit or use unit Wi-Fi page. Make sure that unit touchscreen displays a Wi-Fi RSSI between -30 dB and -80 dB. If possible, remove any object blocking the unit Wi-Fi signal. Make sure that Wi-Fi antenna is connected to the Raymote Wi-Fi module. Improve signal strength in the unit room using a Wi-Fi extender.</p> <p>Static information. Refresh web browser or app and log off and log in again if necessary.</p>

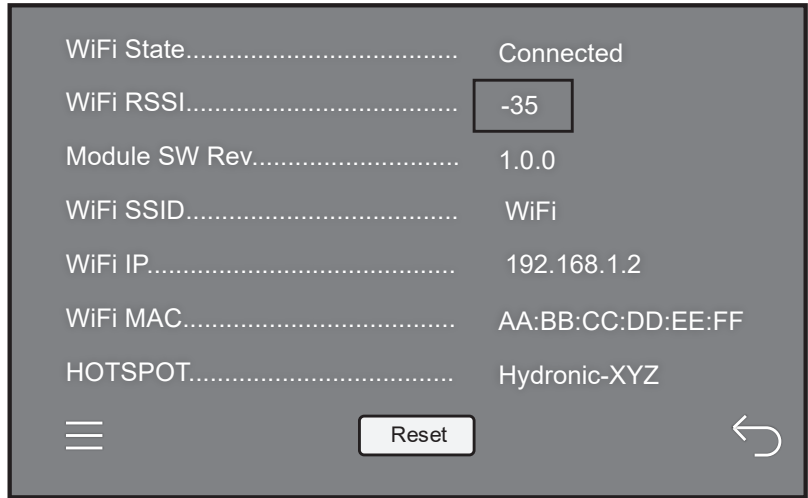

Figure 91. Wi-Fi RSSI

Static IP configuration

By default, Raymote Wi-Fi module is configured automatically by your Wi-Fi router with a dynamic IP address.

To assign manually a **Static IP address** follow the next steps.

NOTE: This configuration requires detailed Wi-Fi network information to work properly. Consult with your local IT team to get this information.

In “Wi-Fi setup” page, click on IP address settings (static IP). See **Figure 92**.

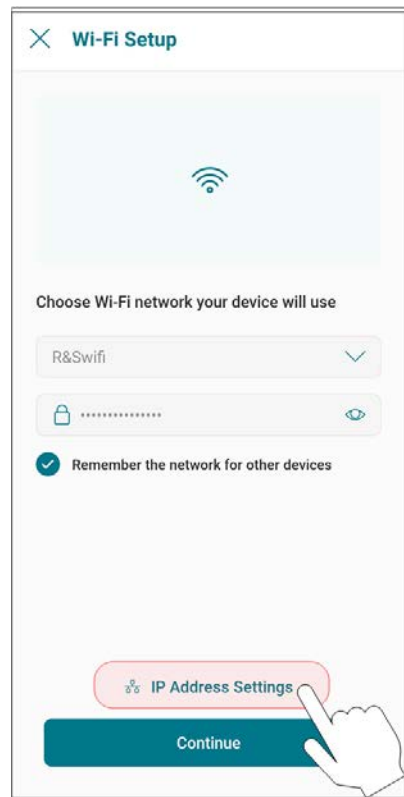

Figure 92. Static IP Option

Activate Static IP configuration by clicking in the “Use Static IP address” slider.

Manually fill the boxes with the network data provided by your IT team.

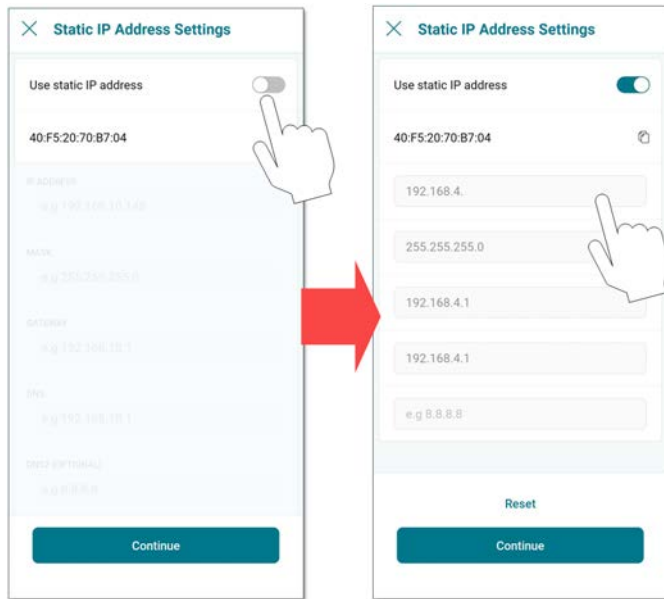

Figure 93. Static IP Address Settings

Alternatively, for Android devices, connect your device to the desired Wi-Fi network and use automatic option to populate network data.

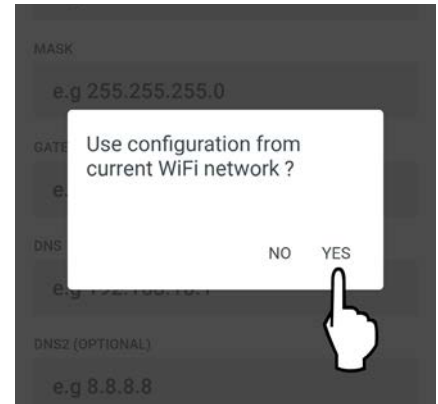

Figure 94. Android Auto Configuration

After writing static IP and network data, press **Continue** to proceed to the setup.



10. DISABLING RAYMOTE

This section describes the procedure to disable Raymote functionality and components. This will ensure that no signal is emitted or received by the antenna.

Before Removal

1. Terminate any active call for heat.
2. Disable the boiler operation in the BOILER menu, or deactivate the enable switch on the unit.
3. Allow the unit to shut down.
4. Turn OFF the boiler main power switch. Make sure the boiler is completely de-energized.
5. Locate the upper front of the boiler and follow the instruction that apply to your product.

MVB and XTherm units

1. Remove the knurled screw that secures the front sheet metal panel. Remove the front panel.

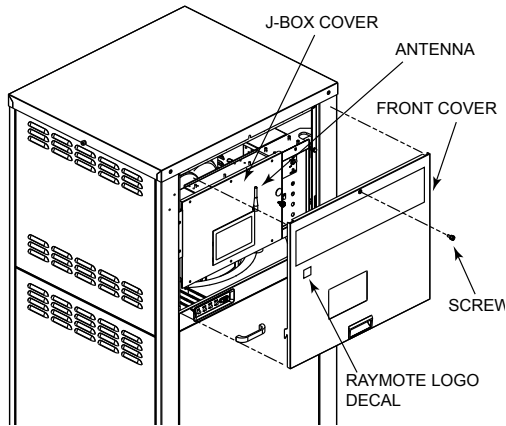

Figure 95. MVB and XTherm Front Panel Removal

2. Remove the j-box cover panel and the power switch mounting panel. Discard the j-box cover panel. It will be replaced with a new j-box cover panel which includes an additional opening to allow for the antenna placement.

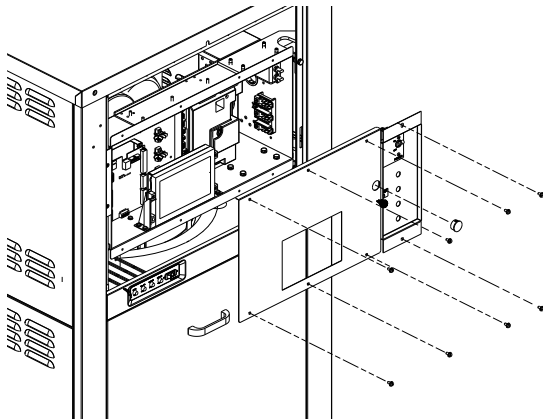

Figure 96. J-Box Cover Removal

3. Remove the power and communication harnesses attached to the back of the touchscreen.
4. Remove the (4) 5/16" hex screws from the touchscreen mounting brackets on the j-box.

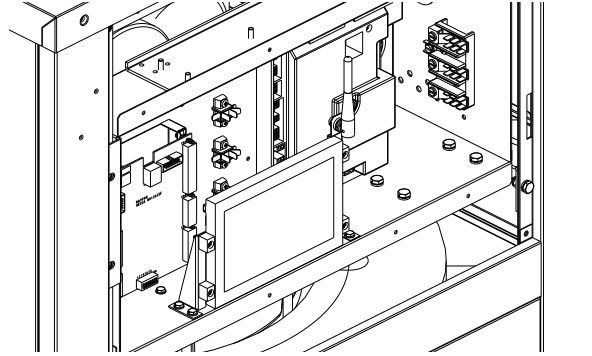

Figure 97. Harness Removal

5. Remove the touchscreen rear cover from the touchscreen.

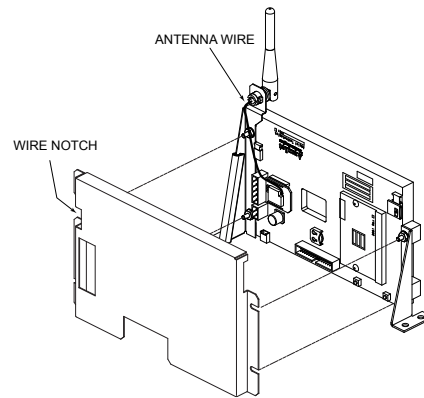

Figure 98. Touchscreen Rear Cover Removal

6. Disconnect the antenna from the Wi-Fi module.
7. Remove the module from the back of the touchscreen.
8. Remove the antenna from the bracket. See Figure 99.

NOTE: For Touchscreens with built-in Wi-Fi module, proceed to cut jumper wire. By cutting this wire, the Wi-Fi module is disabled. Any attempt to modify the wire or modify the board will void touchscreen assembly warranty. See Figure 104.

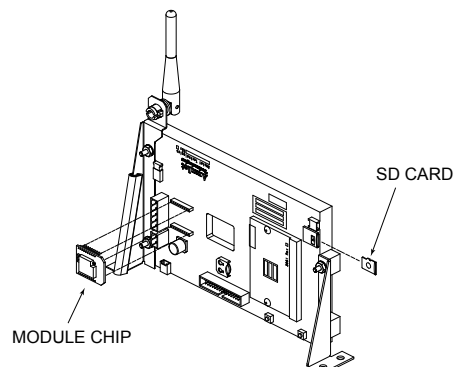

Figure 99. Antenna Removal

- Follow steps 5 to 1 in reverse order to reinstall the screen and close the unit.

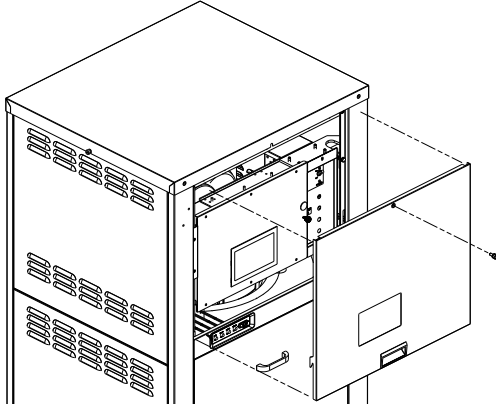

Figure 100. Re-installation

XVers Units

- Release the four snap fasteners to remove the front cover panels from the unit. Remove the panels and place them aside.
- Remove the 5/16" Phillips screw that secures the swing panel.

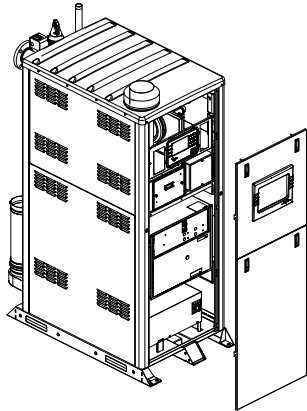

Figure 101. XVers Panel Removal

- Remove the power and communication harnesses attached to the back of the touchscreen.
- Remove the touchscreen rear cover.

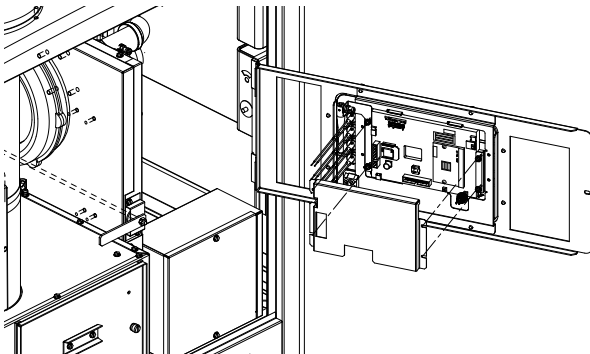

Figure 102. Harness Removal XVers Units

- Disconnect the antenna wire from the Wi-Fi module.

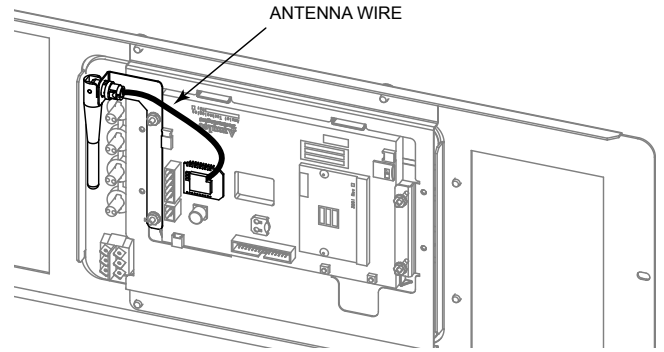

Figure 103. Antenna Wire Removal

- Remove the Wi-Fi module from the touchscreen.

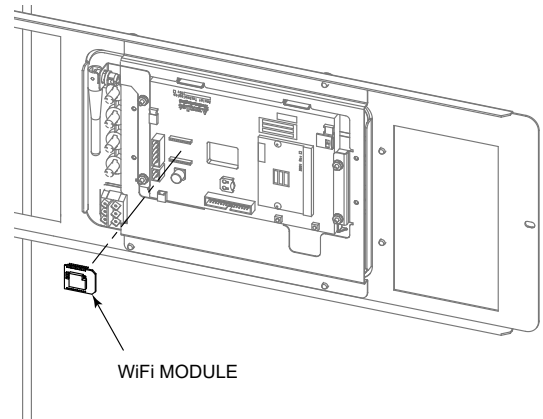

Figure 104. Wi-Fi Module Removal

- Follow steps 4 to 1 in reverse order to reinstall the screen cover and close the unit.

NOTE: For Touchscreens with built-in Wi-Fi module, proceed to cut jumper wire. By cutting this wire, the Wi-Fi module is disabled. Any attempt to modify the wire or modify the board will void touchscreen assembly warranty. See Figure 105.

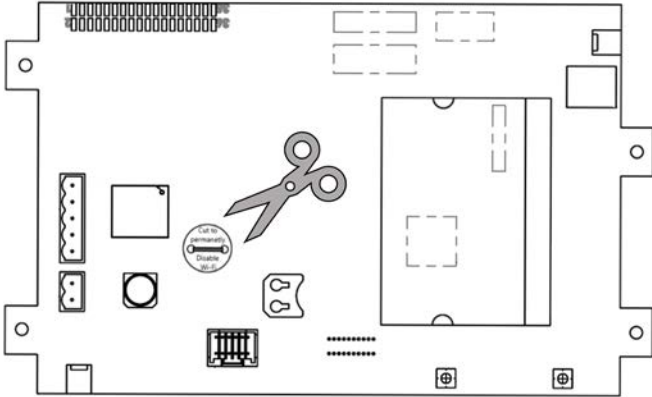

Figure 105. Cut to Disable Wi-Fi

XVers with KOR Units

- Release the four snap fasteners to remove the front cover panels from the unit. Remove the panels and place them aside.
- Remove the 5/16" Phillips screw that secures the swing panel.

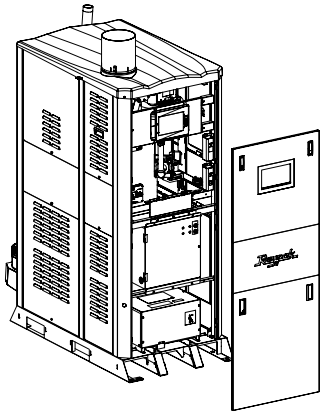

Figure 106. XVers with KOR Panel Removal

- Remove the power and communication harnesses attached to the back of the touchscreen.

- Remove the touchscreen rear cover.
- Cut Wi-Fi jumper per **Figure 105**.

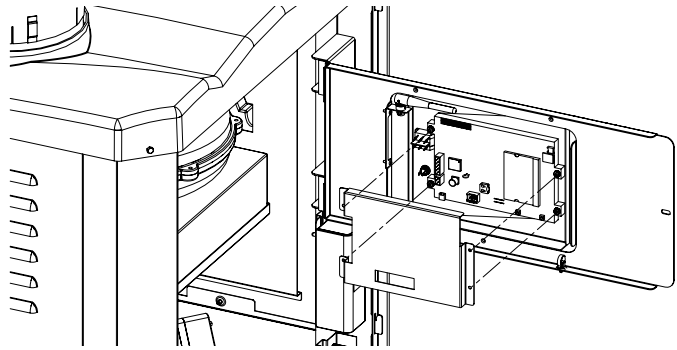

Figure 107. Harness Removal XVers with KOR

- Disconnect the antenna wire from the Wi-Fi module.

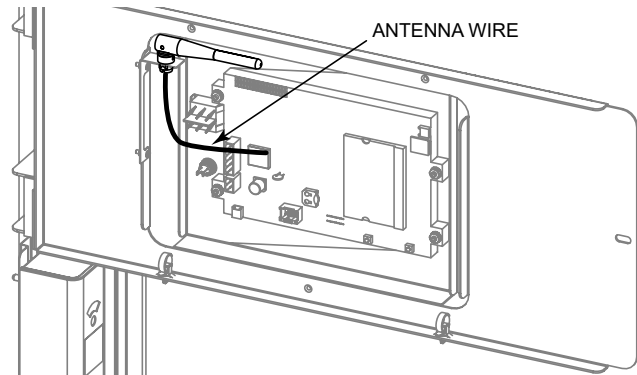

Figure 108. Antenna Wire Removal

- Follow steps 4 to 1 in reverse order to reinstall the screen cover and close the unit.

NOTE: For Touchscreens with built-in Wi-Fi module, proceed to cut jumper wire. By cutting this wire, the Wi-Fi module is disabled. Any attempt to modify the wire or modify the board will void touchscreen assembly warranty. See Figure 105.

XVersL and XFIIRE units

1. Pull the controls bezel to release the 2 snap fasteners.

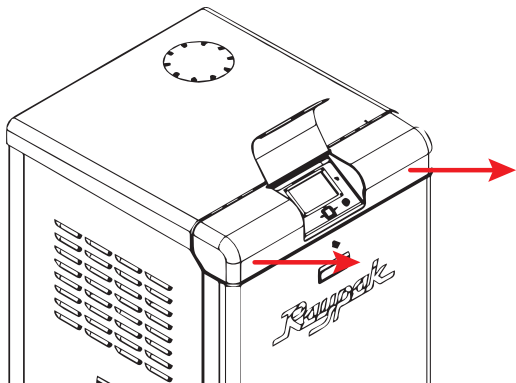

Figure 109. Pull Controls Bezel

2. Gently pull down the bezel to avoid damages to harnesses and control board.
3. Disconnect the touchscreen power cable.

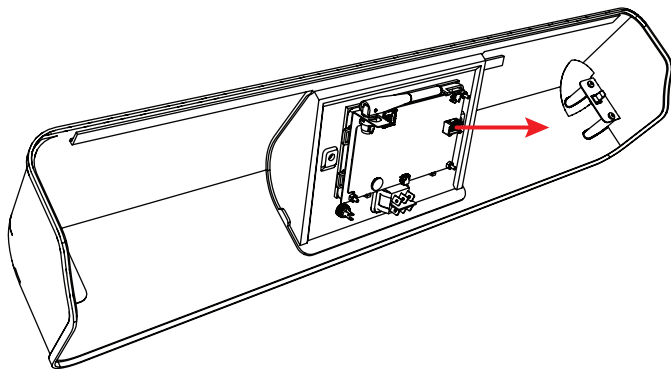

Figure 110. Disconnect Touchscreen Power Cable

4. Use Wire cutters to cut the Wire jumper labeled as "Cut to permanently disable Wi-Fi". See **Figure 111**.

NOTE: By cutting this wire, the Wi-Fi module is disabled. Any attempt to modify the wire or modify the board will void touchscreen assembly warranty.

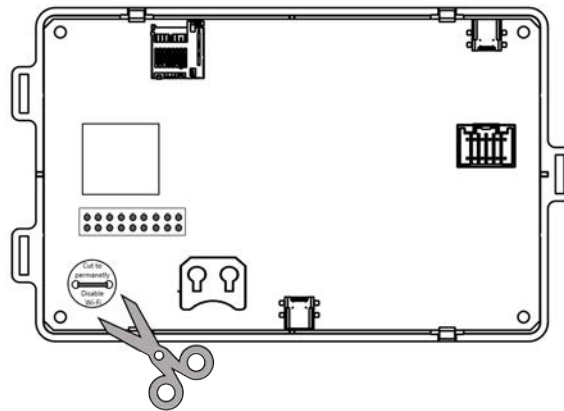

Figure 111. Cut to Disable Wi-Fi

11. QR CODE

View this Installation Manual on your smart device.

This QR Code will take you to the most current version of this manual. Previous versions of manuals can be found in the document library at Raypak.com.

P/N: 241788 Raymote Operation Instructions



This device complies with Part 15 of the FCC Rules. Operation is subject to the following two conditions: (1) This device may not cause harmful interference and (2) this device must accept any interference received, including interference that may cause undesired operation. This device complies with CAN ICES-3 (A)/NMB-3(A).